

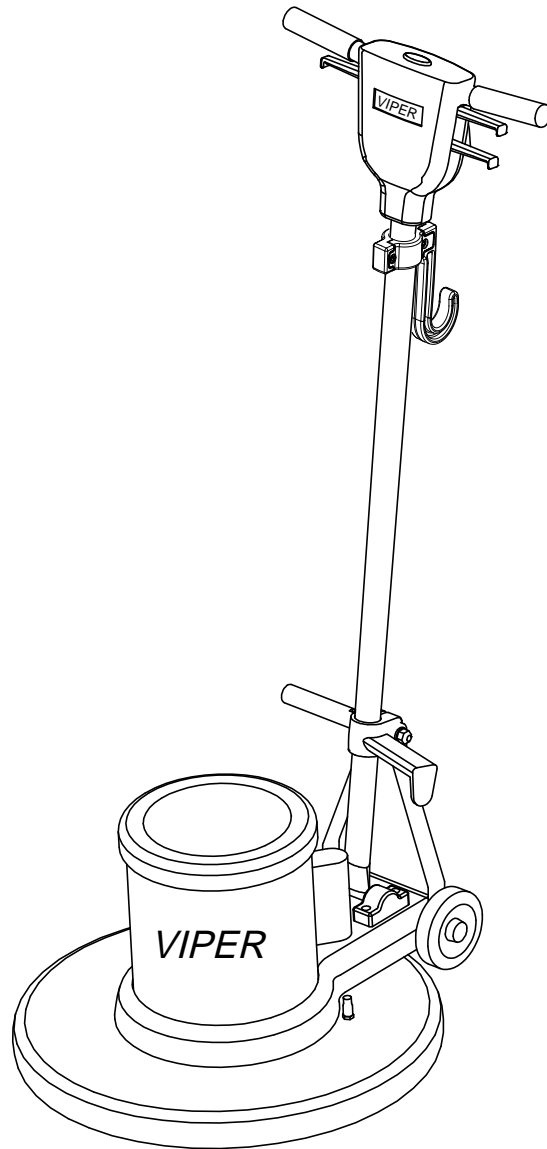

OWNERS MANUAL



MODEL #	<u>VN1715</u>	<u>VN1715-P</u>
SERIAL #	<u>VN2015</u>	<u>VN2015-P</u>



TABLE OF CONTENTS

Safety Precautions	3
Machine Operation	4
Machine Maintenance & Storage	4
Parts List	5 - 8
Wiring Diagram	9

SAFETY PRECAUTIONS

GROUNDING INSTRUCTIONS

General –This floor – finishing machine shall be grounded while in use to protect the operator from electric shock. The machine is provided with a three –conductor cord and a three contact grounding type attachment plug to fit the proper grounding type receptacle. The green [or green and yellow] conductor in the cord is the grounding wire. Never connect this wire to other than the grounding pin of the attachment plug.

This machine is for use on a nominal 120-Volt circuit and has a grounding plug that resembles the plug illustrated in figure below. Make sure that the machine is connected to an outlet having the same configuration as the plug. No adapter should be used with this machine.

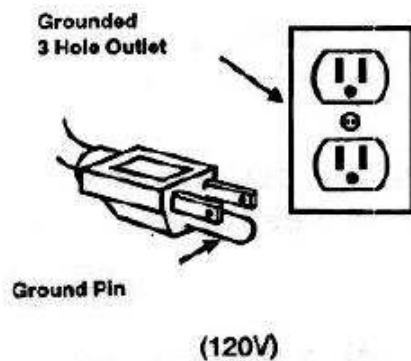

This machine is intended for Commercial use. It is constructed for use in an indoor environment and is not intended for any other use. Use only recommended accessories.

All operators shall read, understand and exercise the following safety precautions:

1] Do not operate machine:

- Unless trained and authorized.
- Unless you have read and understand operators manual.
- In flammable or explosive areas.
- With a damaged cord or plug.
- If not in proper operating condition.
- In outdoor areas.
- In standing water.
- With the use of extension cords.

2] Before operating machine:

- Make sure all safety devices are in place and operate properly.

3] When using machine:

- Do not run machine over cord.
- Do not pull machine by cord or plug.
- Do not pull cord around sharp edges of corners.
- Do not unplug by pulling on the cord.
- Do not stretch cord.
- Do not handle plug with wet hands.
- Keep cord away from heated surfaces.
- Report machine damage or faulty operation immediately.

4] Before leaving or servicing machine:

- Turn off machine.
- Unplug cord from outlet.

5] When servicing machine:

- Unplug cord from outlet.
- Use manufacturer supplied or approved replacements parts.

Operation of Floor Machines

*** READ OPERATORS MANUAL THOROUGHLY PRIOR TO OPERATING OR SERVICING THIS MACHINE.**

GENERAL USE

1. Remove any obstructions or other obstacles in the area which is to be cleaned.
2. Place the handle in the upright position and tilt machine back until handle rests on the floor
 - * Be sure the machine is not plugged into an outlet
3. Attach the pad driver or brush to the machine by placing the clutch plate over the gearbox hub and turning the driver / brush ¼ turn.
4. Place machine back into its upright position.
5. Plug power cord into a grounded outlet.
 - * Never use an extension cord in conjunction with the standard power cord.
6. The handle height may be adjusted by lifting up the compression handle which is located on the right side of the handle tube about 1 foot above floor level. Release the compression handle and adjust handle to safe operating height, then push back down on the compression handle to lock the handle in operating position.
7. To start the machine, press the red safety button on the top of the upper switch housing, and then squeeze either of the operating triggers. (the safety button must be depressed prior to squeezing the operating triggers.)
8. When the machine is in operation, both hands should be placed on the switch housing (upper handle).
9. During operation, to make the machine go right, gently raise the handle. To make the machine go left, gently lower the handle.

10. To stop the machine at any time, simply release the operating trigger(s) and the machine will stop automatically.

MAINTENANCE

To keep the machine performing well for many years, please follow the following maintenance procedures.

* Always confirm that the machine is unplugged prior to performing any maintenance or repairs.

1. Unplug machine as soon as you are done using it.
2. Tilt machine back and remove pad driver or brush.
 - * Never store a low speed machine with the pad driver or brush mounted to the machine.
3. Clean the outside of the machine with a mild cleaner.
4. Check power cord for any damage. If damage is detected, replace power cord immediately.
5. Lubricate wheels with a water resistant lubricant once a month.
6. Check machine for loose or missing nuts and bolts, and replace as necessary.
7. If the machine is used in a dusty environment, you may remove the motor cover and blow the motor clean with compressed air. This will ensure proper ventilation, and allow the motor to run cooler.

STORAGE

1. Unplug machine from power source and wrap cord on handle.
2. Tilt machine back and remove pad driver or brush.
3. Store machine in upright position and in a dry area.

HANDLE GROUP

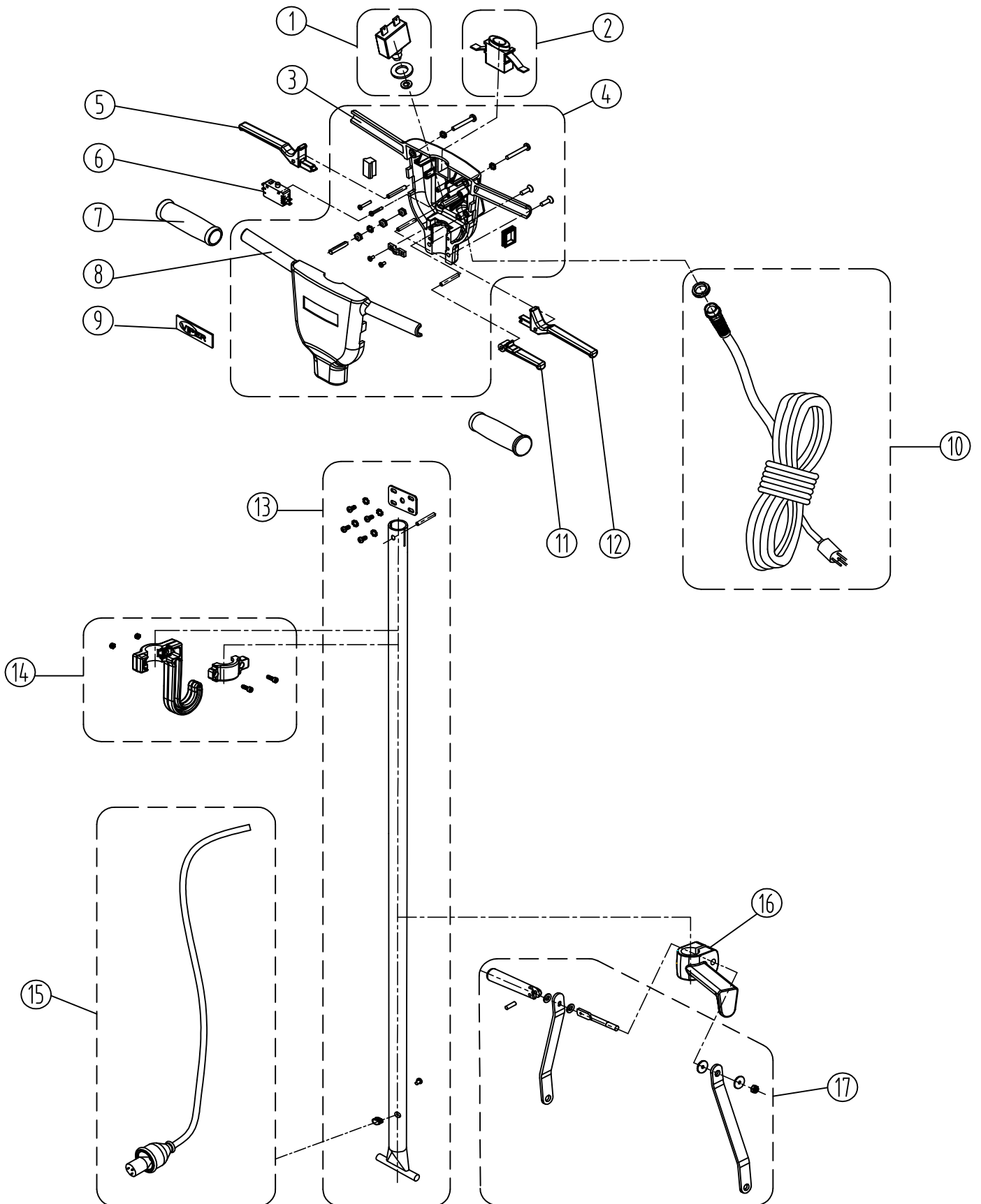

HANDLE GROUP

ITEM	PART NO.	DESCRIPTION	NOTE	QTY
1	VF75252	CIRCUIT BREAKER	A,B	1
1	VF89050	CIRCUIT BREAKER	C,D	1
2	VF75557	SAFETY LOCK BUTTON KIT		1
3	VF30102R	REAR COVER		1
4	VF75558	HANDLE BOX KIT		1
5	VF44017R	LEVER,RIGHT,SWITCH		1
6	VF75251	SWITCH		1
7	VF48310	HANDLE GRIP		2
8	VF30101R	FRONT COVER		1
9	VF47035A	LOGO		1
10	VF75559	POWER CORD KIT		1
11	VF44018R	LEVER,SOLUTION		1
12	VF44016R	LEVER,LEFT,SWITCH		1
13	VF75561	TUBE KIT		1
14	VF75560	HOOK KIT		1
15	VF75563	POWER CORD KIT,INSIDE THE TUBE		1
16	VF300141	CORD WRAP BLOCK		1
17	VF75562	BOLT KIT,HANDLE RELEASE		1

A FOR VN1715

B FOR VN2015

C FOR VN1715-P

D FOR VN2015-P

BASE GROUP

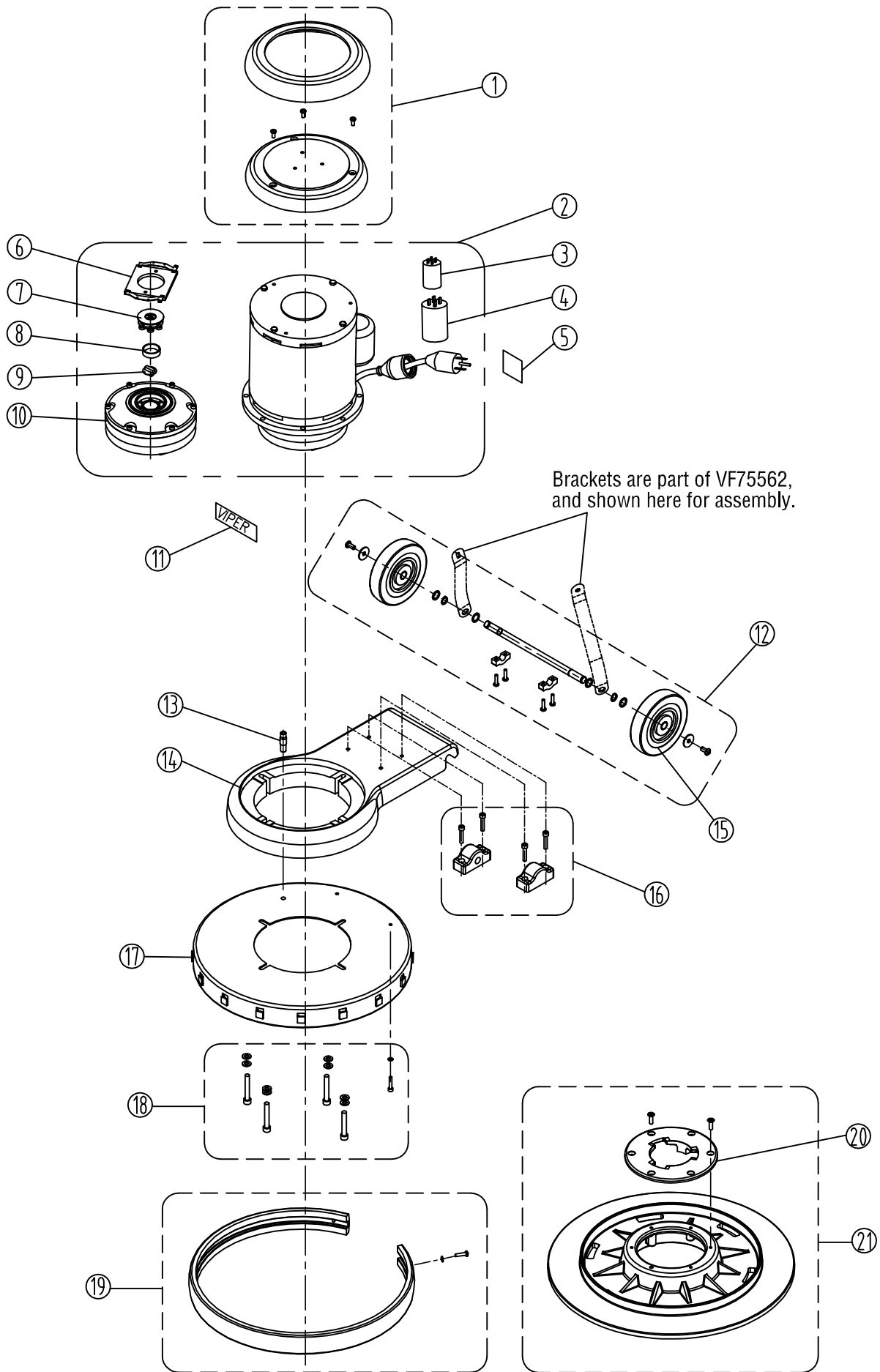

BASE GROUP

ITEM	PART NO.	DESCRIPTION	NOTE	QTY
1	VF75551	TOP COVER KIT,MOTOR		1
2	VF75254	MOTOR	A,B	1
2	VF75253	MOTOR	C,D	1
3	VF75256	RUNNING CAPACITOR	A,B	1
3	VF75273	RUNNING CAPACITOR	C,D	1
4	VF75257	STARTING CAPACITOR	A,B	1
4	VF75272	STARTING CAPACITOR	C,D	1
5	VF41079	READ MANUAL LABEL		1
6	VF75270	STATIONARY SWITCH		1
7	VF75269	CENTRIFUGAL SWITCH		1
8	VF75268	SLEEVE		1
9	VF75267	COUPLER		1
10	VF75266	GEAR BOX		1
11	VF40994	LABEL,VIPER		1
12	VF75553	TRANSPORT WHEEL KIT		1
13	VF40152	BARB HOSE		1
14	VF30008G	FIXATION BASE,MOTOR		1
15	VF75214	WHEEL,5"		2
16	VF75554	CLAMP BLOCK KIT,HANDLE		1
17	VF30006G	FRAME,20-INCH	B,D	1
17	VF30007G	FRAME,17-INCH	A,C	1
18	VF75555	SCREW KIT		1
19	VF75552	BUMPER,17-INCH	A,C	1
19	VF75556	BUMPER,20-INCH	B,D	1
20	MF-VF002-2	CLUTCH PLATE		1
21	MF-VF021	PAD HOLDER,16-INCH	A,C	1
21	MF-VF022	PAD HOLDER,19-INCH	B,D	1

A FOR VN1715

B FOR VN2015

C FOR VN1715-P

D FOR VN2015-P

WIRING DIAGRAM

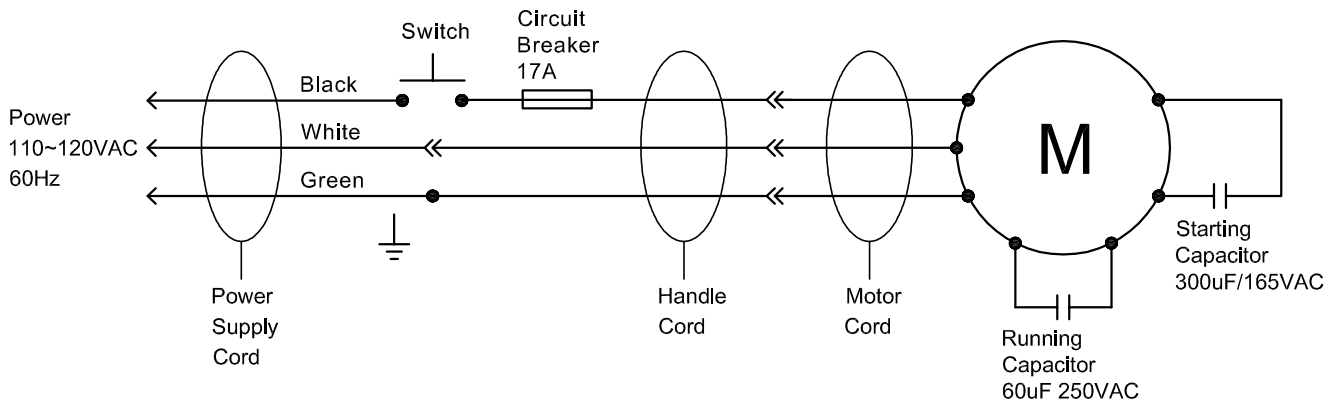

A

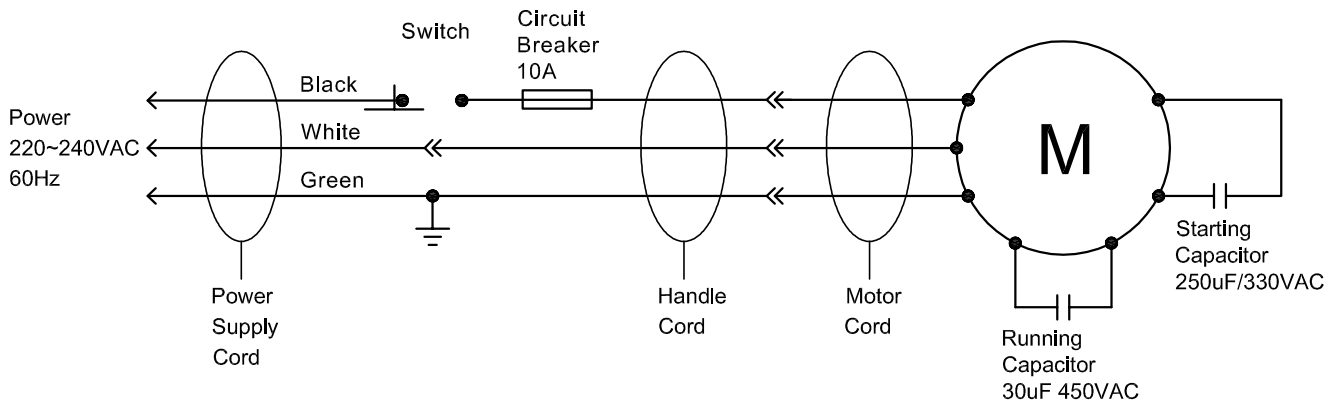

B

A FOR VN1715,VN2015
B FOR VN1715-P,VN2015-P