

# Terra™ 28B

---



---

## PARTS LIST

Advance model: 908 4702 010



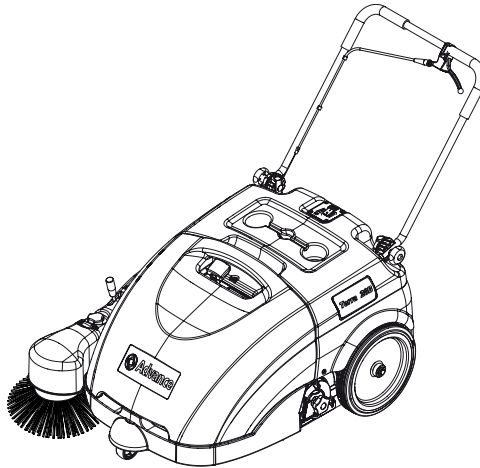

## DESCRIPTION

## PLAN

GENERAL VIEW	2 - 3
CHASSIS SYSTEM	4 - 5
SIDE BROOM ASSEMBLY	6 - 7
HOPPER SYSTEM	8 - 9
TRANSMISSION SYSTEM	10 - 11
RIGHT-LEFT HATCH ASSEMBLIES	12 - 13
BELT TENSIONER ASSEMBLIES	14 - 15
DUST CONTROL SYSTEM	16 - 17
VACUUM SYSTEM AND FILTER ASSEMBLY	18 - 19
CONTROL PANELS SYSTEMS	20 - 21
WIRING DIAGRAM	22
RECOMMENDED SPARE PARTS	23

### WHEN ORDERING PARTS

- \* Use the 8, 9 or 10 digit numbers from the "Ref. No." columns in this parts list.
- \* Specify the model and serial number of the machine.
- \* Use the space below to record the model and serial number for future reference.

Model \_\_\_\_\_ Serial No. \_\_\_\_\_

**\* = Optional**

**# = Modified item No. or New item No.**

**[ ] = Not shown**

GENERAL VIEW

2007-01

2

Terra™ 28B

2009-02

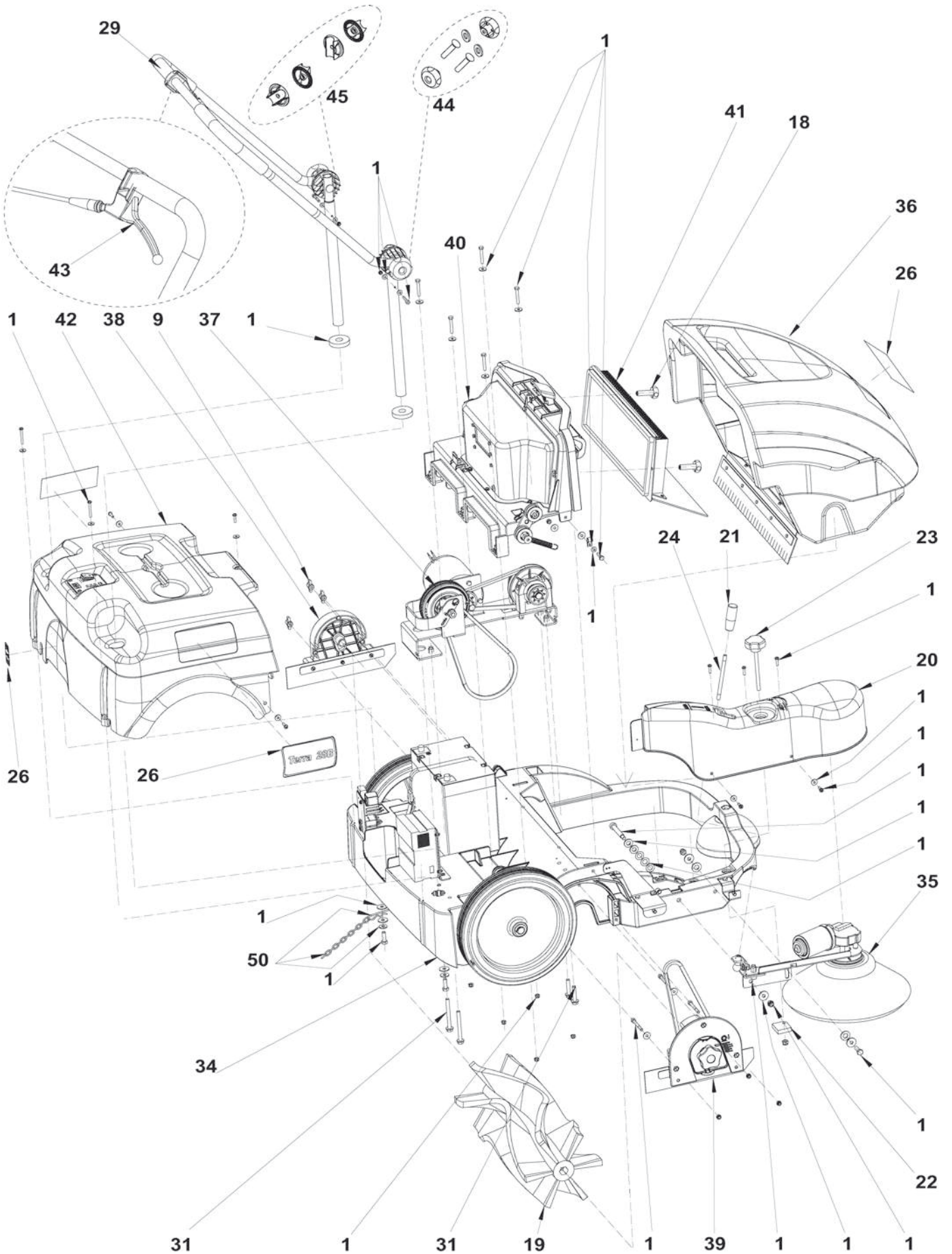

2007-01	GENERAL VIEW			
2009-02	Terra™ 28B			3

Item	Ref. No.	Qty	Description
1#	1463858000	1	HARDWARE MAIN KIT
9	145 0461 000	3	WING NUT M6
18	146 2991 000	2	HANDWHEEL M6
19	1463202000	1	MAIN BROOM D.200
20	146 3033 000	1	SIDE CASE
21	146 3037 000	1	HANDLE
22	146 3038 000	1	BROOM SIDE ADJUSTER BLOCK
23	146 3039 000	1	HANDWHEEL M8
24	146 3040 000	1	SIDE BROOM LEVER
26#	1463983000	1	DECALS Terra 28B KIT
29	146 3066 000	1	HANDLE BAR
31#	1463868000	1	HARDWARE TRANSMISSION SYSTEM KIT
34		1	CHASSIS SYSTEM
35		1	SIDE BROOM ASSEMBLY
36		1	HOPPER SYSTEM
37		1	TRANSMISSION SYSTEM
38		1	LEFT HATCH ASSEMBLY
39		1	RIGHT HATCH ASSEMBLY
40		1	DUST CONTROL SYSTEM
41		1	FILTER ASSEMBLY
42		1	CONTROL PANEL ASSEMBLY
43	146 3068 000	1	ACCELERATOR LEVER
44#	1463859000	1	HANDLE FIXING KIT
45#	909 5099 000	1	RATCHET HANDLE ADJUSTER KIT
50#	1463260000	1	CHAIN KIT

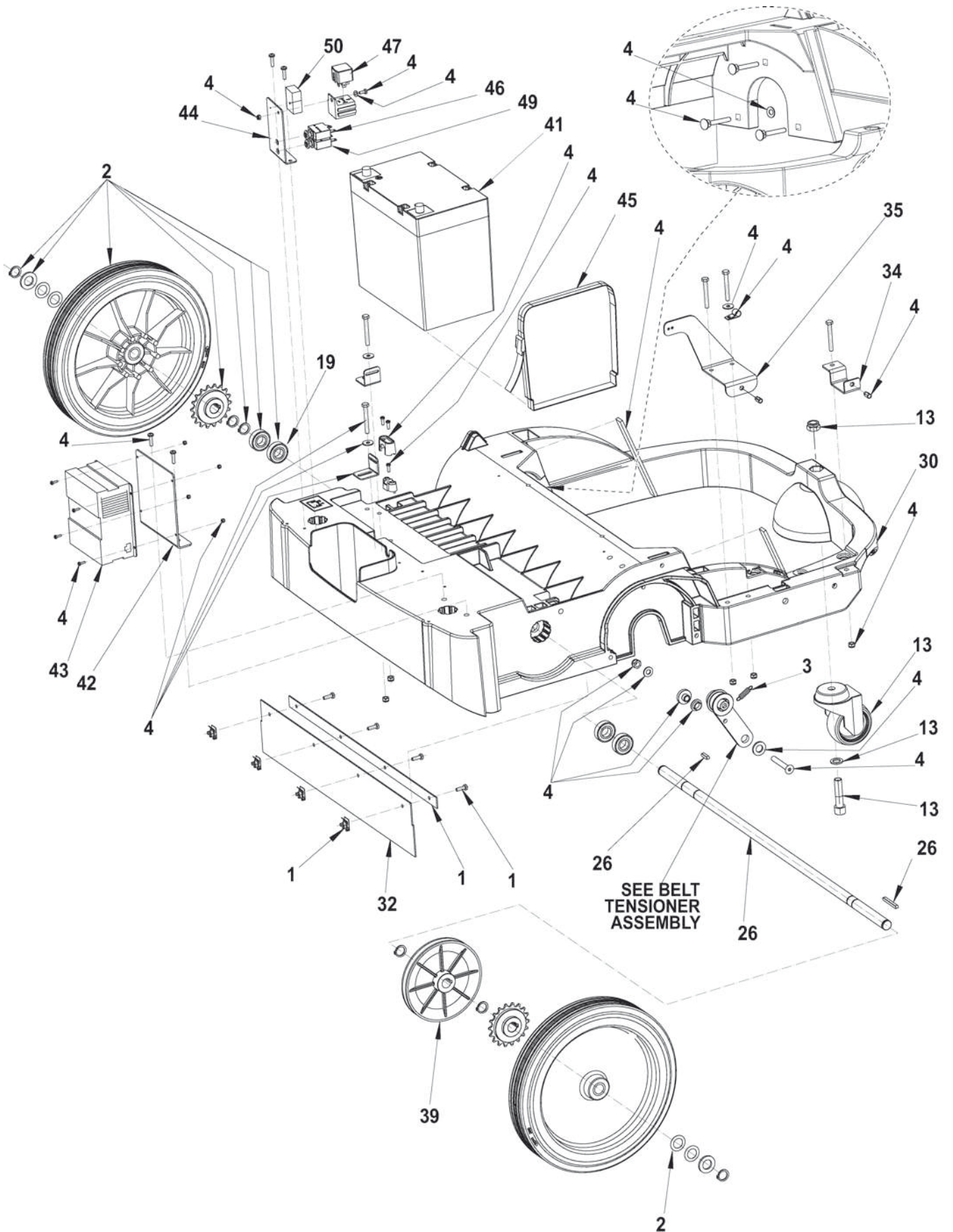

2007-01	CHASSIS SYSTEM			
2009-02	Terra™ 28B			5

Item	Ref. No.	Qty	Description
1#	146 3124 000	1	PLATES AND SKIRTS FIXING KIT
2#	1463860000	2	WHEEL KIT
3#	145 8925 000	1	SPRING
4#	1463861000	1	HARDWARE TRANSMISSIONE SYSTEM KIT
13#	1463862000	1	WHEEL CASTOR KIT
19	145 8415 000	4	BALL BEARING
26#	1463863000	1	SHAFT WHEELS KIT
30	146 2978 000	1	CHASSIS
32	1463167000	1	NO MARKING SKIRTS KIT
34	146 2983 000	1	CARTER FIXING BRACKET
35	146 2984 000	1	CARTER FIXING BRACKET
39	146 2998 000	1	PULLEY Ø140
41#	1463254000	1	BATTERY 12V 80AH GEL
42	146 3050 000	1	BATT. CHARGER FIX BRACKET
43	146 3051 000	1	BATTERY CHARGER 12V 6AH
44	146 3053 000	1	ELECTRONIC COMP. SUPPORT
45	146 3054 000	1	BATTERY FIXING BELT
46	146 3090 000	1	CIRCUIT BREAKER 5A
47	146 3113 000	1	RELAIS 12V 70A TYCO
49	909 5706 000	1	CIRCUIT BREAKER 30A
50	909 6341 000	1	FUSE CARRIER
[58]	146 3052 000	1	MACHINE HARNESS
[60]#	1463303000	1	SKIRTS NO MARKING W/HARDWARE KIT (1 - 32)
[63]	909 5633 000	1	CABLE EXTENTION
[64]#	145 9788 000	1	FUSE 7,5A

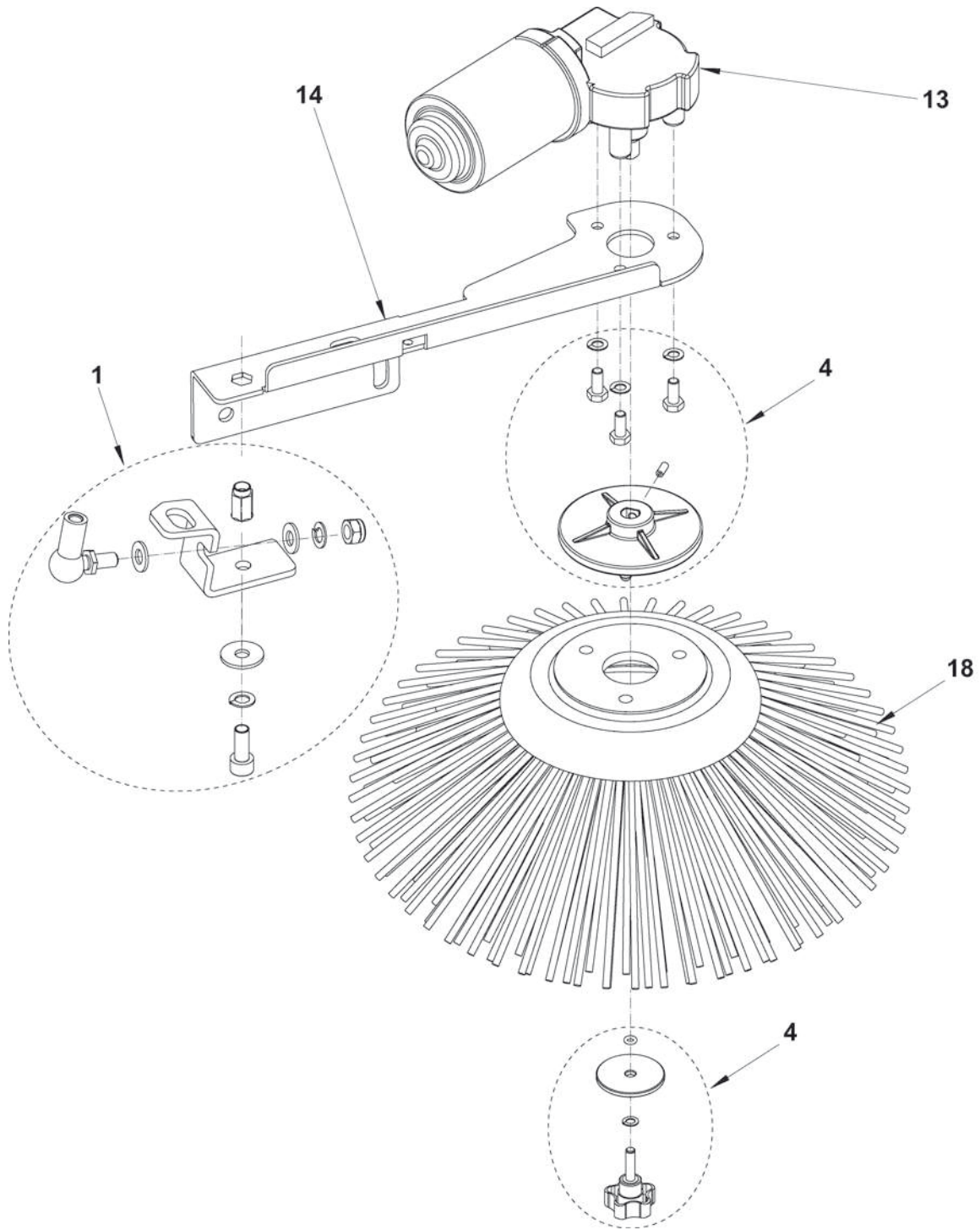



2007-01	<b>SIDE BROOM ASSEMBLY</b>			
2009-02	<b>Terra™ 28B</b>			<b>7</b>

Item	Ref. No.	Qty	Description
1#	1463864000	1	HARDWARE SIDE BROOM KIT
4#	1463865000	1	BROOM SIDE HUB FIXING KIT
13	146 3028 000	1	REDUCTION GEAR MOTOR
14	146 3029 000	1	SIDE BROOM SUPPORT
18	146 3035 000	1	SIDE BROOM Ø315 PPL 0,5

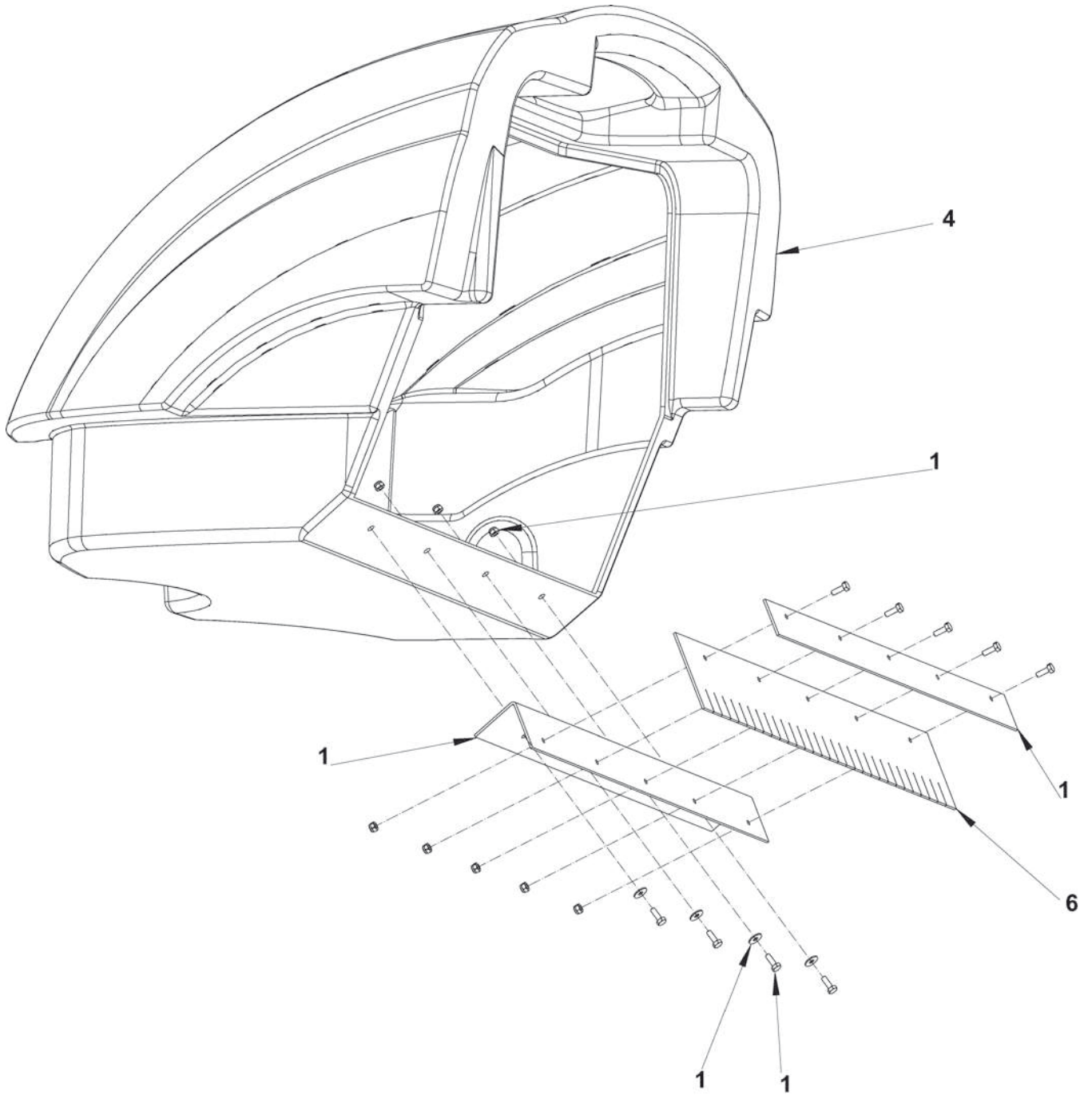

2007-01	<b>HOPPER SYSTEM</b>		
2009-02	<b>Terra™ 28B</b>		<b>9</b>

Item	Ref. No.	Qty	Description
1	146 3124 000	1	PLATES AND SKIRTS FIXING
4	146 3042 000	1	DIRT CONTAINER
6	1463167000	1	SKIRTS NO MARKING KIT
[7]#	1463303000	1	SKIRTS NO MARKING W/HARDAWARE KIT (1-6)

TRANSMISSION SYSTEM

2007-01

10

Terra™ 28B

2009-02

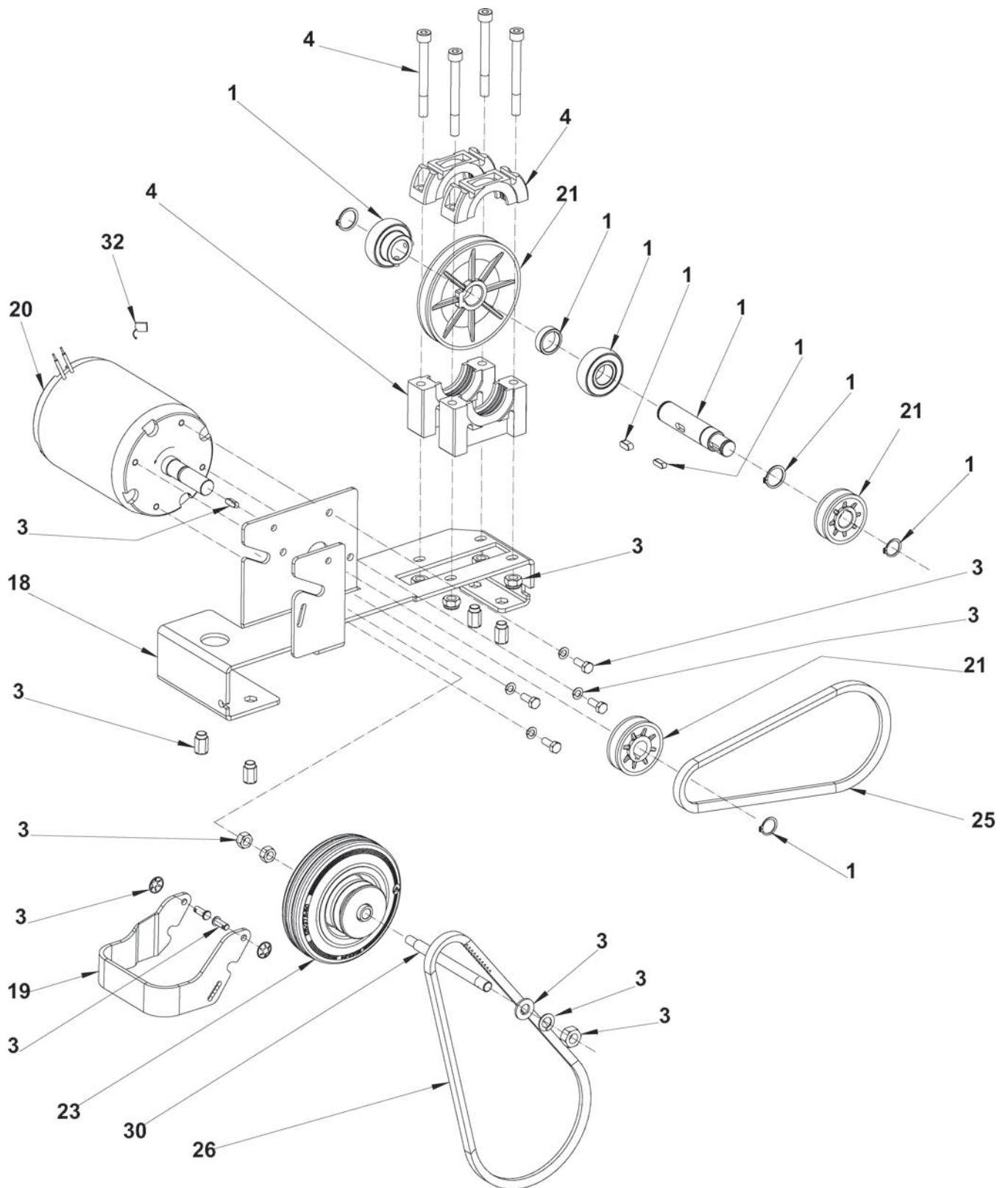

2007-01	<b>TRANSMISSION SYSTEM</b>			
2009-02	<b>Terra™ 28B</b>			<b>11</b>

Item	Ref. No.	Qty	Description
1#	1463867000	1	SHAFT PULLEYS KIT
3#	1463868000	1	HARDWARE TRANSMISSION SYSTEM KIT
4#	1463866000	1	BEARINGS SUPPORTS KIT
18	146 3000 000	1	MOTOR SUPPORT PLATE
19	146 3002 000	1	BRACKET
20	146 3003 000	1	ELECTRIC MOTOR 12V 200W
21#	1463869000	1	PULLEYS KIT
23	146 3006 000	1	FRICTION WHELL
25#	1463305000	1	BELT
26	146 3009 000	1	BELT
30	146 3013 000	1	SHAFT
32	146 3143 000	1	CARBON BRUSH W/COVER KIT 4PCS

LEFT HATCH ASSEMBLY

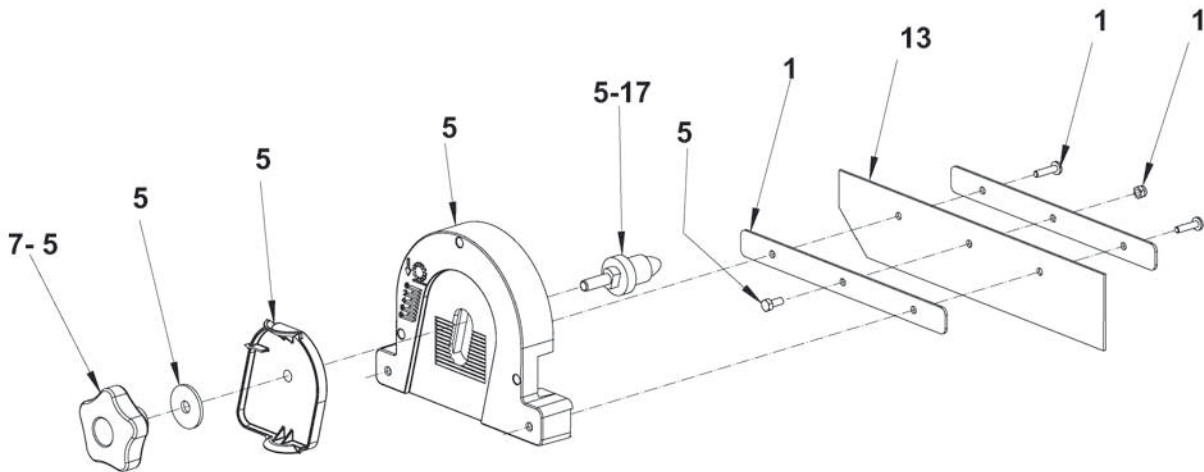

RIGHT HATCH ASSEMBLY

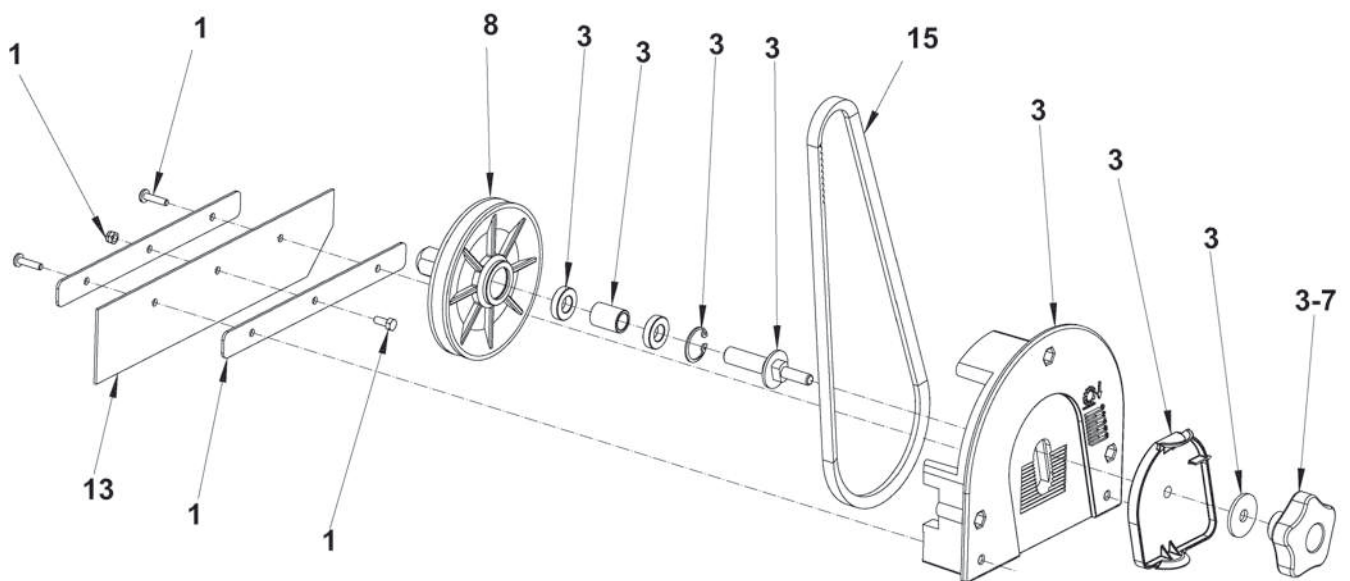

2007-01	<b>LEFT AND RIGHT HATCH ASSEMBLIES</b>			
2009-02	<b>Terra™ 28B</b>			<b>13</b>

Item	Ref. No.	Qty	Description
1	146 3124 000	1	PLATES AND SKIRTS FIXING
3#	1463870000	1	HATCH RIGHT FIXING KIT
5#	1463871000	1	HATCH LEFT FIXING KIT
7	146 1852 000	2	HANDWHEEL
8	146 3014 000	1	PULLEY
13	1463167000	1	SKIRTS NO MARKING KIT
15	146 3027 000	1	BELT
17	146 3020 000	1	MAIN BROOM PIN
[18]#	1463303000	1	SKIRTS NO MARKING W/HARDAWARE KIT (1-13)

**DOUBLE BELT TENSIONER ASSEMBLY**

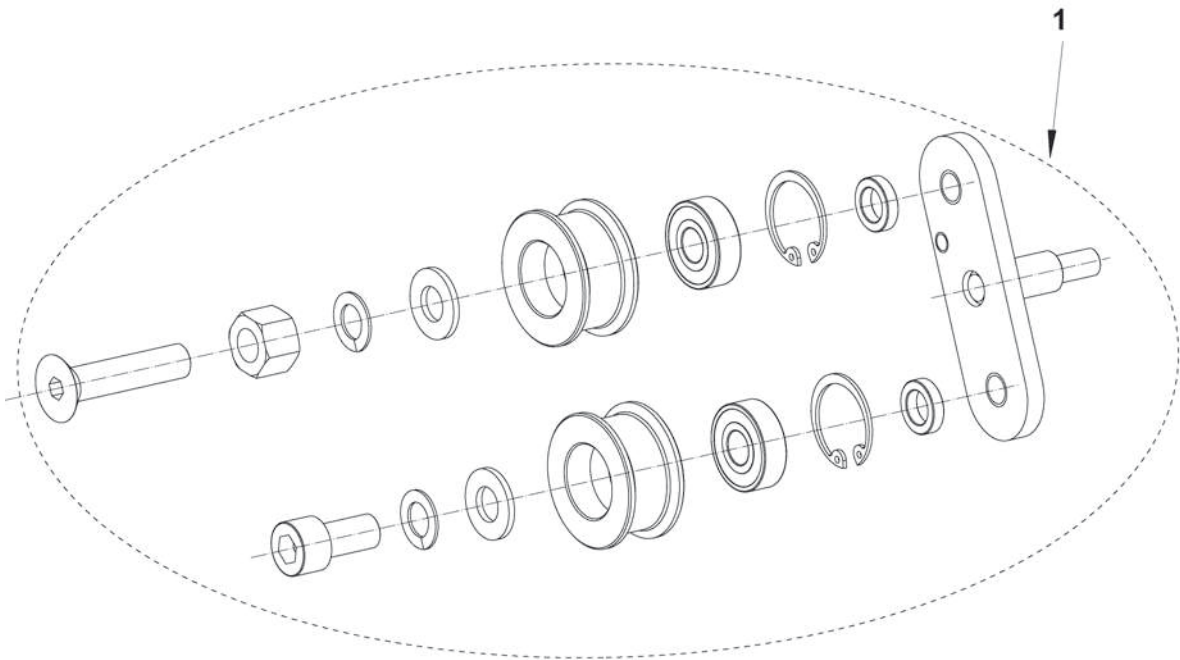

**BELT TENSIONER ASSEMBLY**

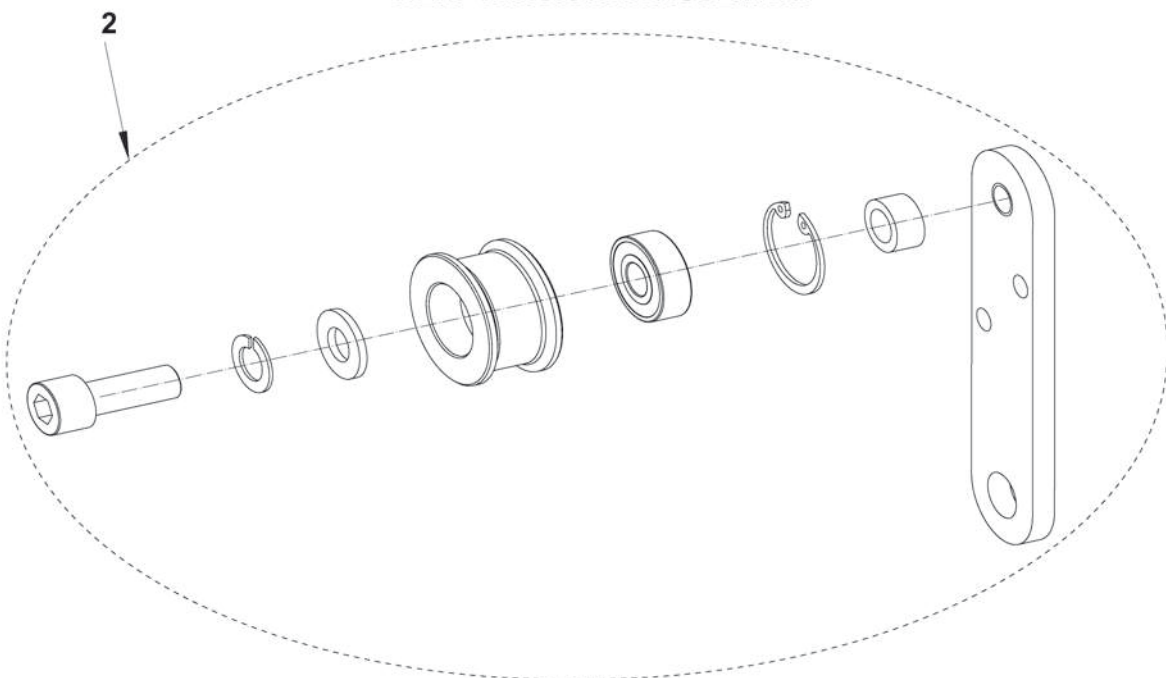



2007-01	<b>BELT TENSIONER ASSEMBLIES</b>			
2009-02	<b>Terra™ 28B</b>			<b>15</b>

Item	Ref. No.	Qty	Description
1#	1463872000	1	BELT TENSIONER DOUBLE KIT
2#	1463873000	1	BELT TENSIONER KIT

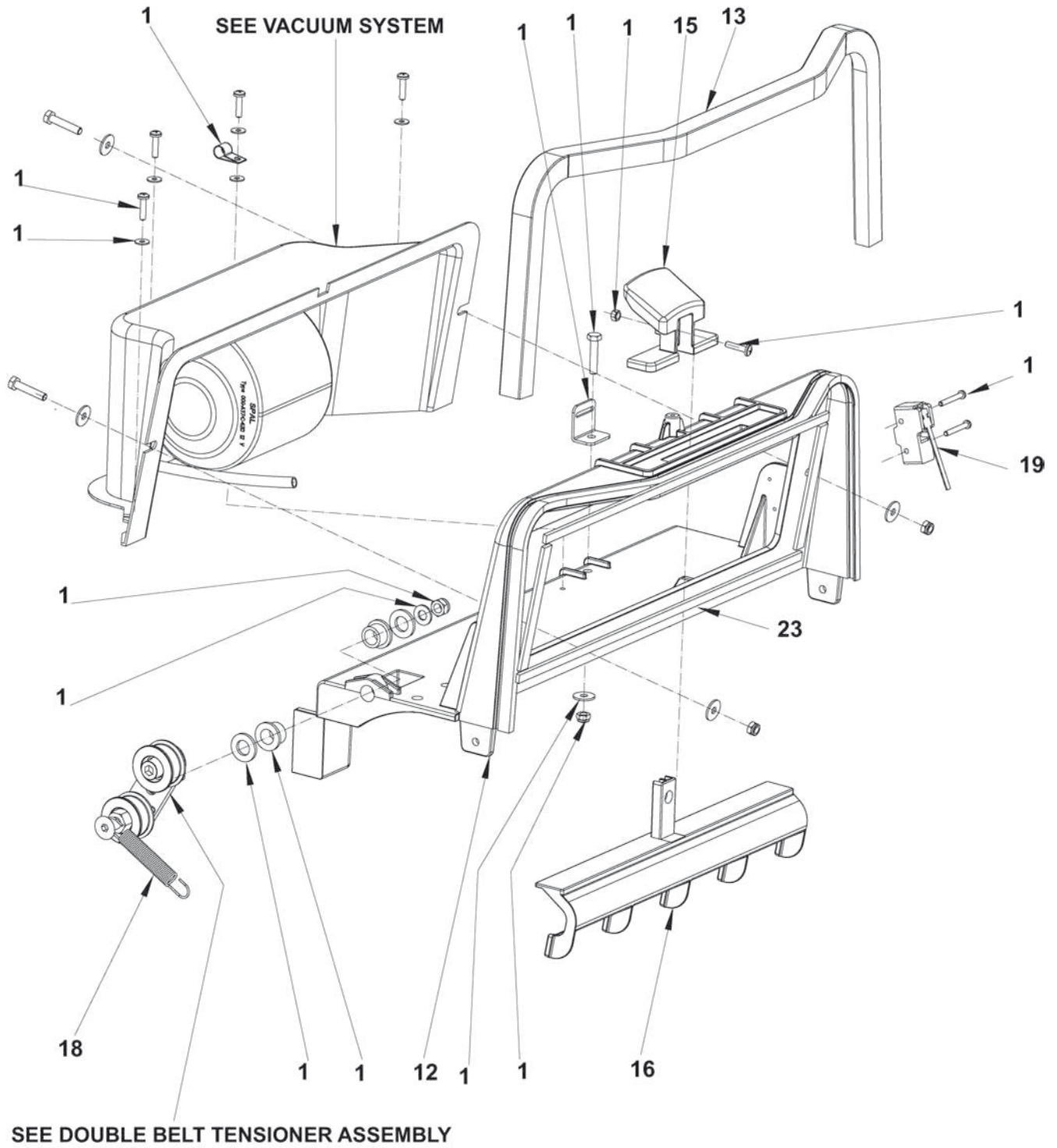

2007-01	<b>DUST CONTROL SYSTEM</b>			
2009-02	<b>Terra™ 28B</b>			<b>17</b>

Item	Ref. No.	Qty	Description
1#	1463874000	1	HARDWARE DUST CONTROL SYSTEM
12	146 2988 000	1	FILTER SUPPORT
13#	1463747000	1	GASKET
15	146 2992 000	1	FILTER SHAKER HANDLE
16	146 2993 000	1	FILTER SHAKER
18	145 0274 000	1	SPRING
19	145 9679 000	1	MICROSWITCH
23	1463176000	1	GASKET KIT

ASSIEME ASPIRAZIONE - VACUUM SYSTEM

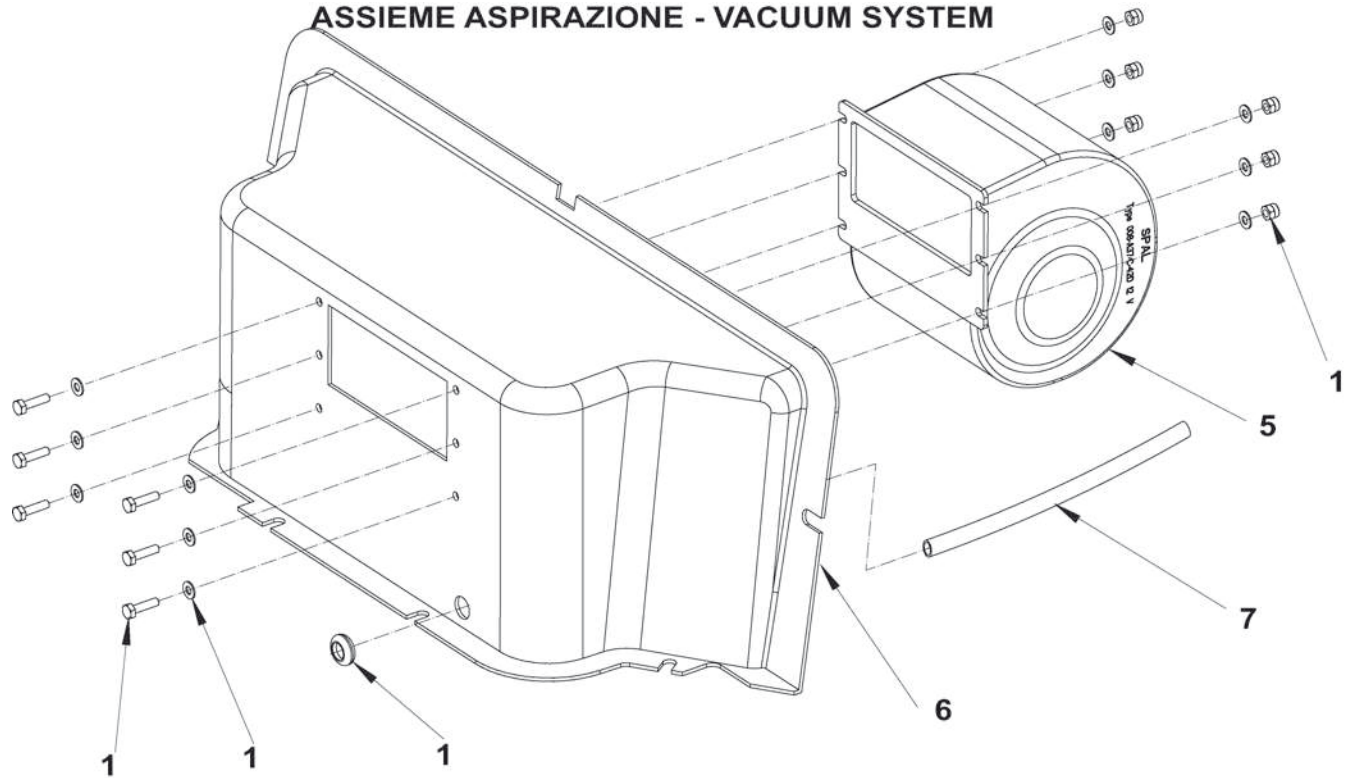

GRUPPO FILTRO - FILTER ASSEMBLY

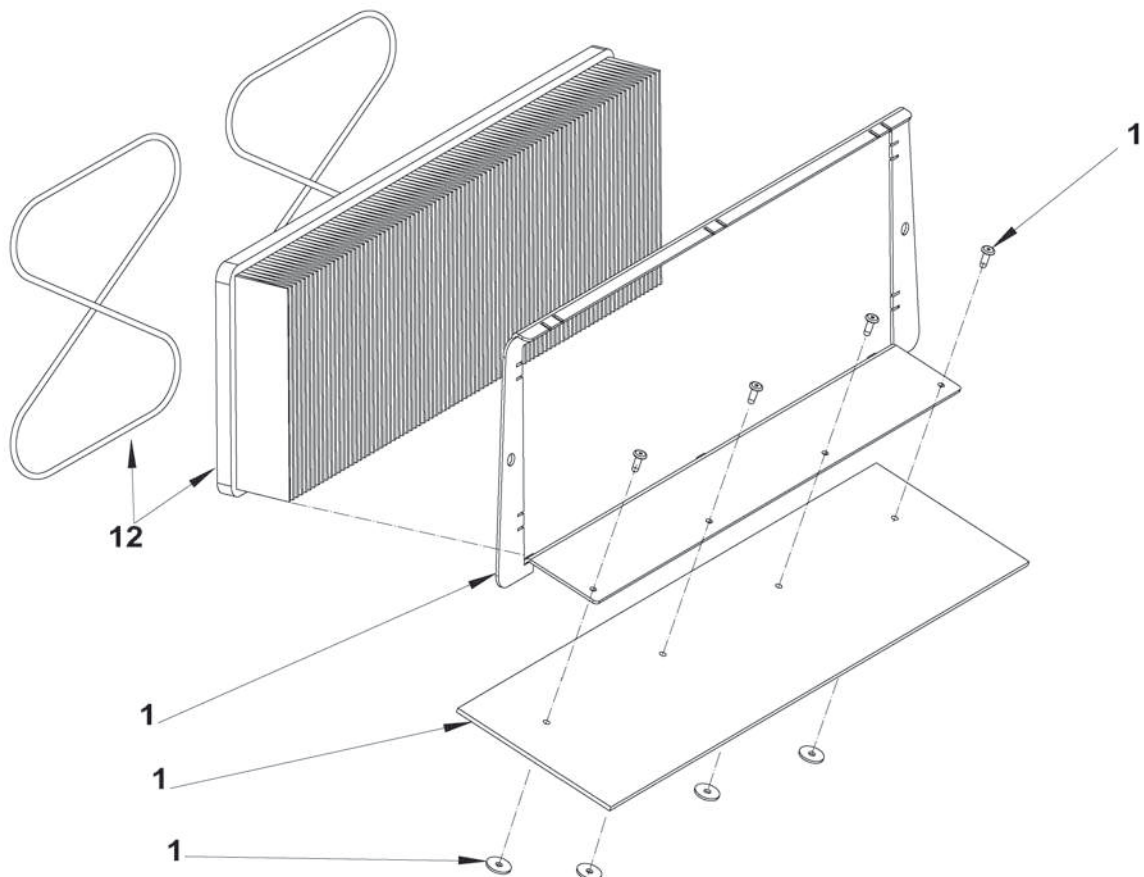

2007-01	VACUUM SYSTEM AND FILTER ASSEMBLY			
2009-02	Terra™ 28B			19

Item	Ref. No.	Qty	Description
1#	1463875000	1	HARDWARE FILTER FIXING KIT
5	146 1804 000	1	FAN 12V
6	146 3055 000	1	CONVOYER
7	146 3125 000	1	SHEATH D.7 L.200
12	1463161000	1	POLYESTER FILTER

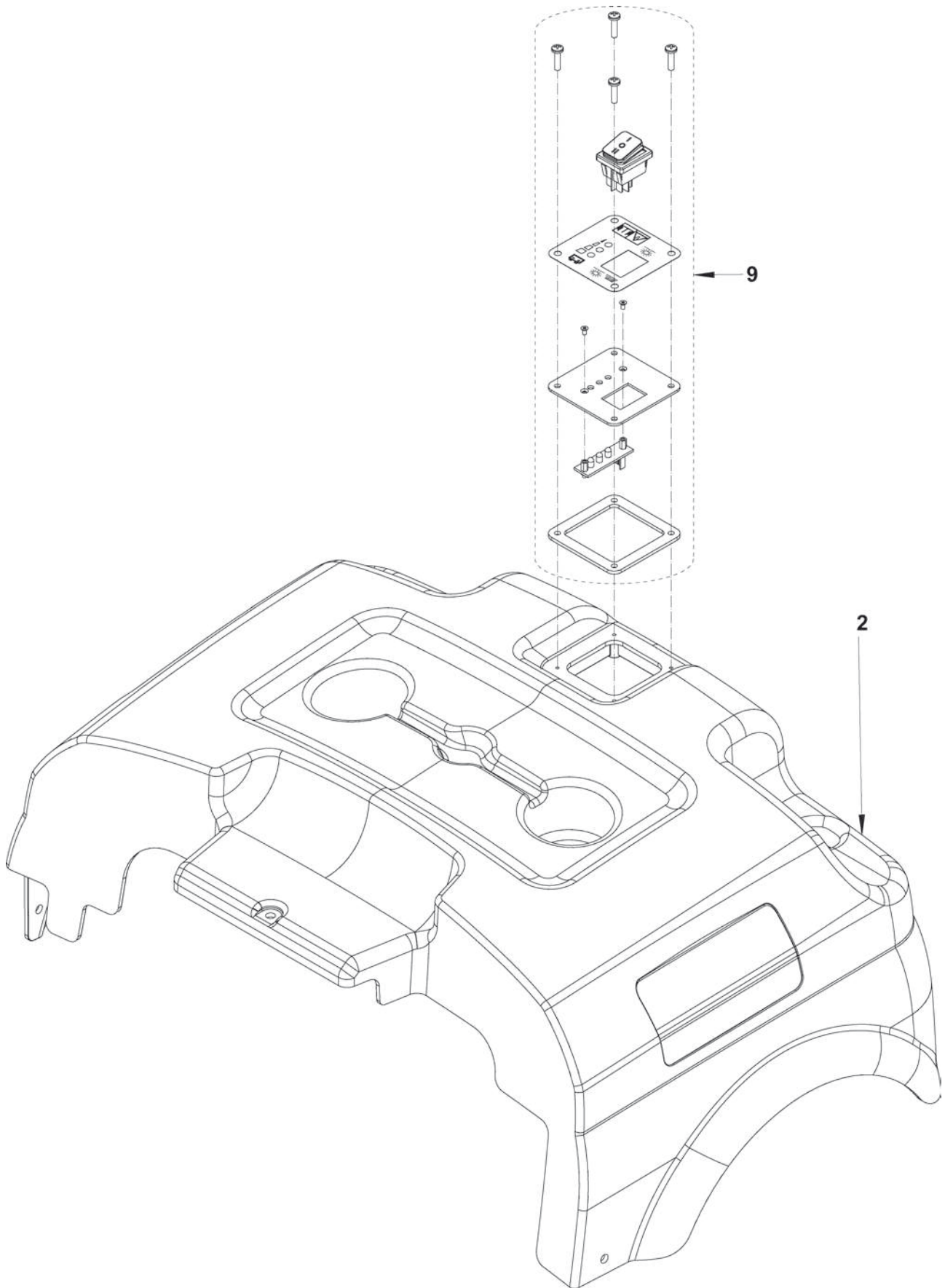

2007-01	<b>CONTROL PANEL ASSEMBLY</b>			
2009-02	<b>Terra™ 28B</b>			<b>21</b>

Item	Ref. No.	Qty	Description
2	146 3069 000	1	REAR BONNET
9	146 3123 000	1	CONTROL PANEL KIT

WIRING DIAGRAM

TERRA 28B

146 3089 000 - Rev.B

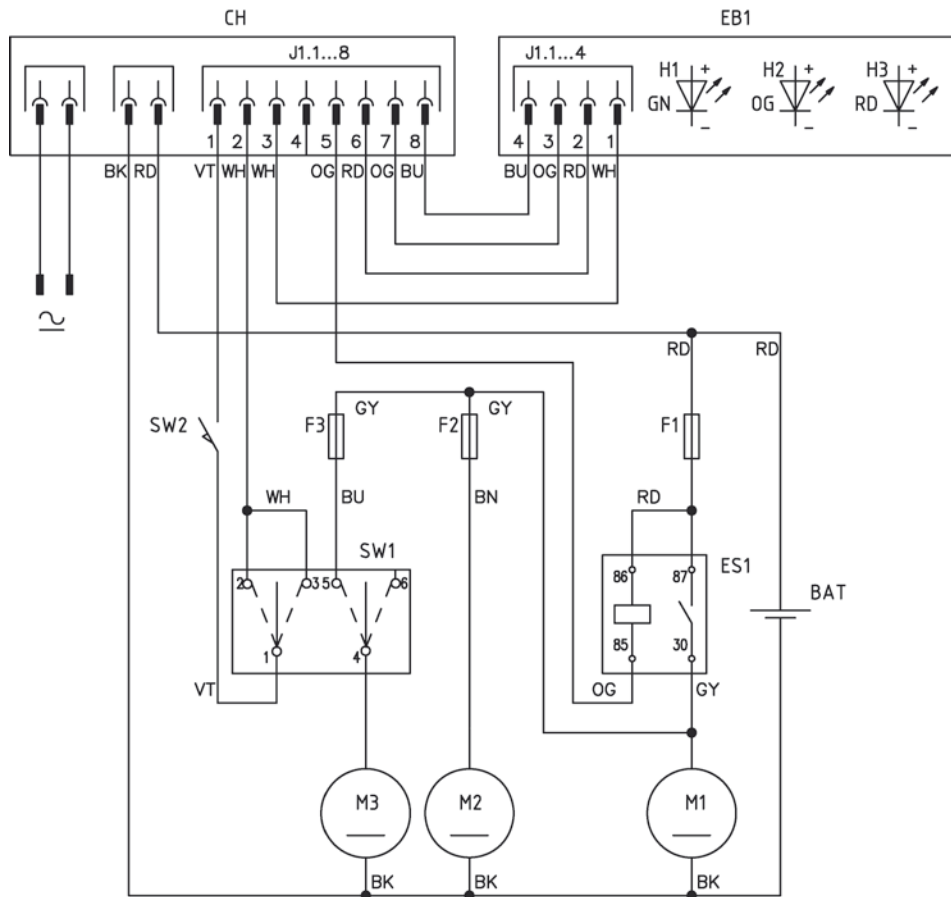

COMPONENTS	
BAT	12V Battery
CH1	Batt. charger / Function controller
EB1	LED board
ES1	Relais
F1	Main circuit breaker
F2	Fan fuse
F3	Side broom circuit breaker
H1	Full charge led
H2	Half charge led
H3	Empty charge led
M1	Main motor
M2	Fan
M3	Side broom motor
SW1	Switch
SW2	Hopper microswitch



2007-01	<b>RECOMMENDED SPARE PARTS</b>		
2009-02	<b>Terra™ 28B</b>		<b>23</b>

Item	Ref. No.	Qty	Description
<b>WEAR PARTS</b>			
#	1463167000	1	KIT NON-MARKING SKIRTS
	146 3035 000	1	SIDE BROOM Ø315 PPL 0,5
	1463202000	1	MAIN BROOM D.200 PPL 0,6 BL
	146 3027 000	1	BELT
<b>ORDINARY MAINTENANCE</b>			
	1463161000	1	POLYESTER FILTER
	146 3009 000	1	BELT
#	146 3305 000	1	BELT
<b>EXTRAORDINARY MAINTENANCE</b>			
#	1463860000	1	WHEEL BLACK KIT
	146 1804 000	1	FAN 12V
	909 5706 000	1	FUSE 30A
	146 3051 000	1	BATTERY CHARGER 12V 6Ah
#	1463254000	1	BATTERY 12V 80AH GEL
	146 3113 000	1	RELAIS 12V 70A TYCO
	146 3090 000	1	FUSE 5A
	146 3123 000	1	KIT CONTROL PANEL
	146 3003 000	1	ELECTRIC MOTOR 12V 200W
	145 9679 000	1	MICROSWITCH
	146 3028 000	1	REDUCTION GEAR MOTOR



**Nilfisk-Advance, Inc.**

14600 21st Avenue North  
Plymouth, MN, 55447-3408

[www.nilfisk-advance.com](http://www.nilfisk-advance.com)

Phone: 800-989-2235

Fax: 800-989-6566

©2008 Nilfisk-Advance, Inc.,

Plymouth, MN 55447-3408

Printed in Hungary