

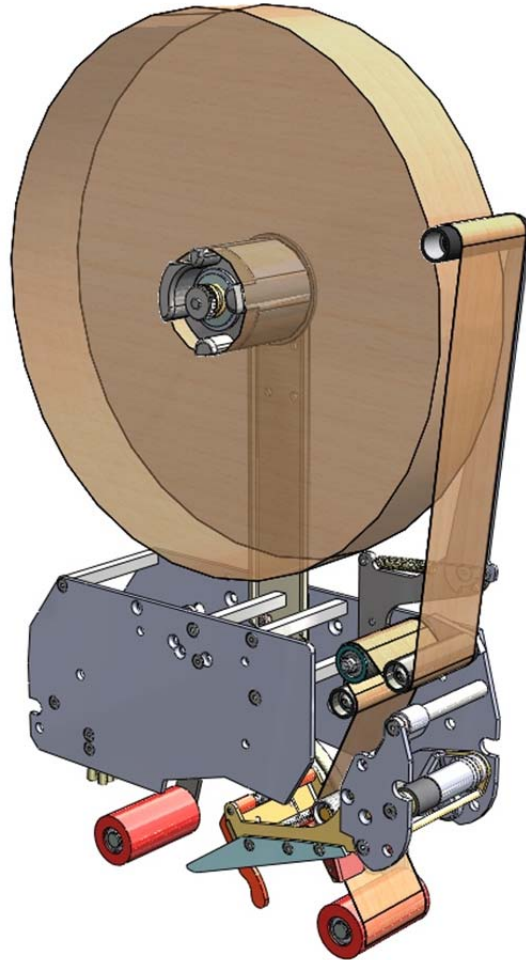

INTERPACK

TAPE HEADS



HSD2000 ET II **Standard & SS Tape Head**

OPERATION MANUAL & PARTS LISTS **2" (48mm) & 3" (72mm)**

**This Manual Covers Tape Heads with the Serial Numbers Starting with:
H175, H675, H177 or H677**

For All Other Numbers, Please Contact Customer Service @ 800-474-8273

TABLE OF CONTENTS

Section 1	Table Of Contents -----	3
Section 2	Technical Assistance -----	4
Section 3	Warranty -----	5
Section 4	Description Of Tape Head -----	6
Section 5	Safety Issues -----	7
Section 6	Specifications -----	10
	Tape Head Dimensions -----	10
	Tape Head Components -----	11
	Tape Head Specifications -----	12
	Installation In Other Machinery -----	13
Section 7	Set Up Procedures -----	14
	Mounting Adapters -----	15
	Tape Loading -----	16
	Tape Threading -----	17
	Tape Centering -----	19
	Tape Leg Length Adjustment -----	20
	One Way Clutched Roller Adjustment -----	21
	Main Spring Adjustment -----	21
	Mandrel Tension Adjustment -----	22
Section 8	Troubleshooting -----	23
Section 9	Recommended Spare Parts List -----	26
Section 10	Preventive Maintenance -----	28
	Knife Blade Replacement -----	28
	Oiler Pad Lubrication -----	29
	Urethane Wipe Down Roller Replacement -----	30
	Spring Replacements -----	31
	Wipe Down Brush Replacement -----	38
	Schedule Of Preventive Maintenance -----	39
Section 11	Appendix A-Illustrations And Parts Lists -----	40
	No Tape Option -----	68
	Low Tape Option -----	70

TECHNICAL ASSISTANCE

Technical Support

This is the Interpack Model HSD 2000-ET II Series Tape Head you ordered. It has been set up and tested in our factory with Intertape brand tapes. If any problems occur when setting up or operating this equipment, please contact the authorized distributor from where you purchased this item.

Should you need to contact **Interpack Technical Support**, please have the Tape Head **model number and serial number** available. This information can be found on the nameplate of the side panel of the tape head. Interpack Technical Support is available during normal business hours (Eastern Time).

PHONE 1-800-972-4675

If you have a technical question that does not require an immediate response, you may contact Interpack by fax.

FAX 1-800-462-1293

Replacement Parts

Order parts by item number, part name and quantity required. Replacement parts are only available from your Authorized Interpack Distributor exclusively.

Should you require assistance selecting the correct part, you may call:

Intertape Polymer Group
Interpack Machinery
9940 Currie Davis Drive, Suite 23B
Tampa, FL, 33619

Tel: 1-800-972-4675

Fax: 1-813-621-8449

MODEL: _____

SERIAL NUMBER: _____

DISTRIBUTOR PURCHASED FROM: _____

DATE OF PURCHASE: _____

WARRANTY

EQUIPMENT WARRANTY AND LIMITED REMEDY: The following warranty is made in lieu of all other warranties, express or implied, including, but not limited to, the implied warranty of merchantability, the implied warranty of fitness for a particular purpose, and any implied warranty arising out of a course of dealing, a custom or usage of trade:

Intertape sells its Interpack Tape Heads, Case Tapers and Case Erectors with the following warranties:

1. The HSD® 2000 Tape Heads' knife blades, springs and wipe down rollers will be free from all defects for a period of ninety (90) days.
2. All other HSD® 2000 Tape Head parts will be free from all defects for one (1) year after delivery.
3. Water Activated Tapers' blades and brushes will be free from defects for ninety (90) days after delivery
4. Drive Belts will be free from defects for ninety (90) days after delivery
5. The Gear Motors will be free from defects for one (1) year after delivery.
6. All other components will be free from defects for one (1) year after delivery.

If any part is proven defective within its warranty period, then the exclusive remedy and Intertape's and the seller's sole obligation shall be, at Intertape's option, to repair or replace the part, provided the defective part is returned immediately to Intertape's factory or an authorized service station designated by Intertape.

A part will be presumed to have become defective after its warranty period unless the part is received or Intertape is notified of the problem no later than five (5) calendar days after the warranty period.

If Intertape is unable to repair or replace the part within a reasonable time, then Intertape, at its option, will replace the equipment or refund the purchase price. Intertape shall have no obligation to install the repaired or replacement part.

Intertape shall have no obligation to provide or pay for the labor required to install the repaired or replacement part. Intertape shall have no obligation to repair or replace (1) those parts failing due to: operator misuse, carelessness, or due to any accidental cause other than equipment failure, or (2) parts

1. Failure or damage is due to misapplication, lack of proper maintenance, abuse, improper installation or abnormal conditions such as temperature, moisture, dirt or corrosive matter, etc.
2. Failure due to inadequate cleaning, improper operating environment, improper utilities or operator error.
3. Failure due to operations above the rated capacities, or in any other improper manner, either intentional or otherwise.
4. Failure is due to equipment, which has been altered by anyone other than an authorized representative of Intertape Polymer Group.
5. Failure is due to an attempt by the purchaser to correct alleged defective equipment. In this event the purchaser is responsible for all expenses incurred.

LIMITATION OF LIABILITY: Intertape and seller shall not be liable for direct, indirect, special, incidental or consequential damages based upon breach of warranty, breach of contract, negligence, strict liability or any other legal theory.

The foregoing Equipment Warranty and Limited Remedy and Limitation of Liability may be changed only by written agreement signed by authorized officers of Intertape and seller.

DESCRIPTION OF TAPE HEAD

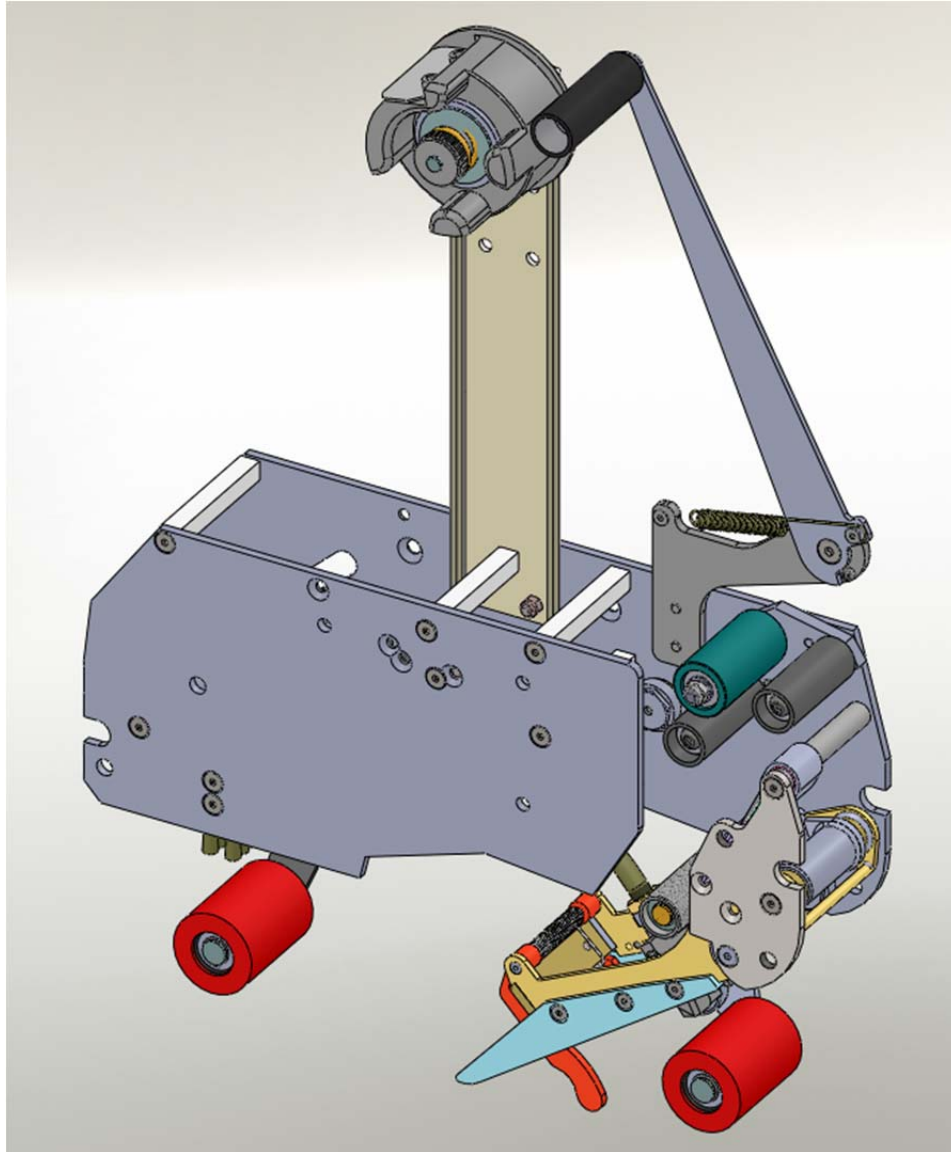

Figure 4-1

The Intertape HSD 2000-ET II Family of Tape Heads are designed to apply Intertape brand pressure sensitive carton sealing tape to the top and bottom center seam of regular slotted corrugated cartons.

The HSD 2000-ET II is the standard tape head in all Interpack machinery.

This HSD 2000-ET II is also designed to upgrade most competitive case sealers. Interpack can provide a variety of adapter kits to install this tape head into most case sealers.

SAFETY ISSUES

There is a safety label used on all Interpack Tape Heads. This label is placed on the Tape Head knife guard to warn operators and service personnel of the sharp cutting edge of the blade. Please read the label and the following safety precautions before using the Tape Head.

- ✓ **Read this manual for other important safety operating and service information.**
- ✓ **Only trained personnel are to operate and service Tape Head.**
- ✓ **Wear safety glasses.**
- ✓ **Shut off power to machine before adjusting.**
- ✓ **Unplug electrical power before servicing.**
- ✓ **All covers and guards must be in place before operating.**
- ✓ **Stay clear of moving parts which can shear and cut.**
- ✓ **Never operate the Tape Heads with the Knife Guard removed.**
- ✓ **Turn electrical supply off before servicing the Tape Heads, including tape loading and threading.**

Note: Should any of the safety labels placed on the Tape Head be damaged or destroyed, replacements are available.

SAFETY ISSUES

The illustrated label shown in **Figure 5-1** is attached to the Knife Guard. The label warns operators and service personnel of the very sharp blade. The guard shall only be removed when the torsion spring or the guard itself are being replaced.

Should the tape head be operated without blade guard, user voids all warranty implied, the manufacturer bears no responsibility for the consequences.

Tape head shall never be serviced while mounted in a machine.



Figure 5-1

Label on Figure 5-2 is visible on carton sealing machine.



Figure 5-2

While the tape head is processing cartons, or it is in motion, keep your hands away (Figure 5-3).



Figure 5-3

The illustrated label shown in **Figure 5-2** is attached to the operator side plate of each tape head. The label provides operators and service personnel the proper method of threading a new roll of tape through the tape head.

More detailed information is provided in the "Set Up Procedures" portion of this manual.

Turn air and electrical supplies off before servicing the tape heads.

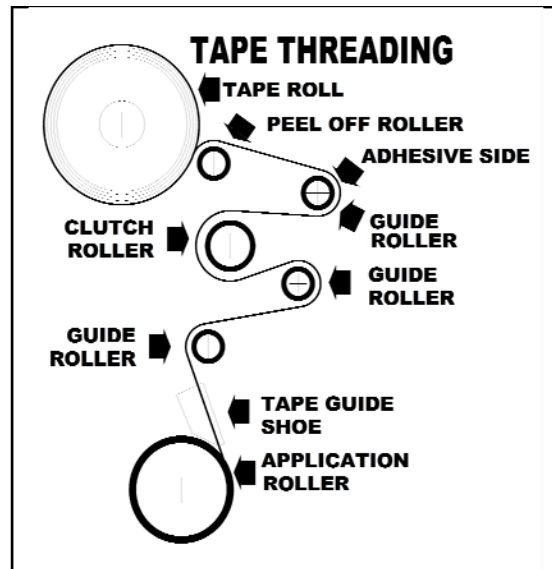

Figure 5-4

SPECIFICATIONS

Tape Head Dimensions

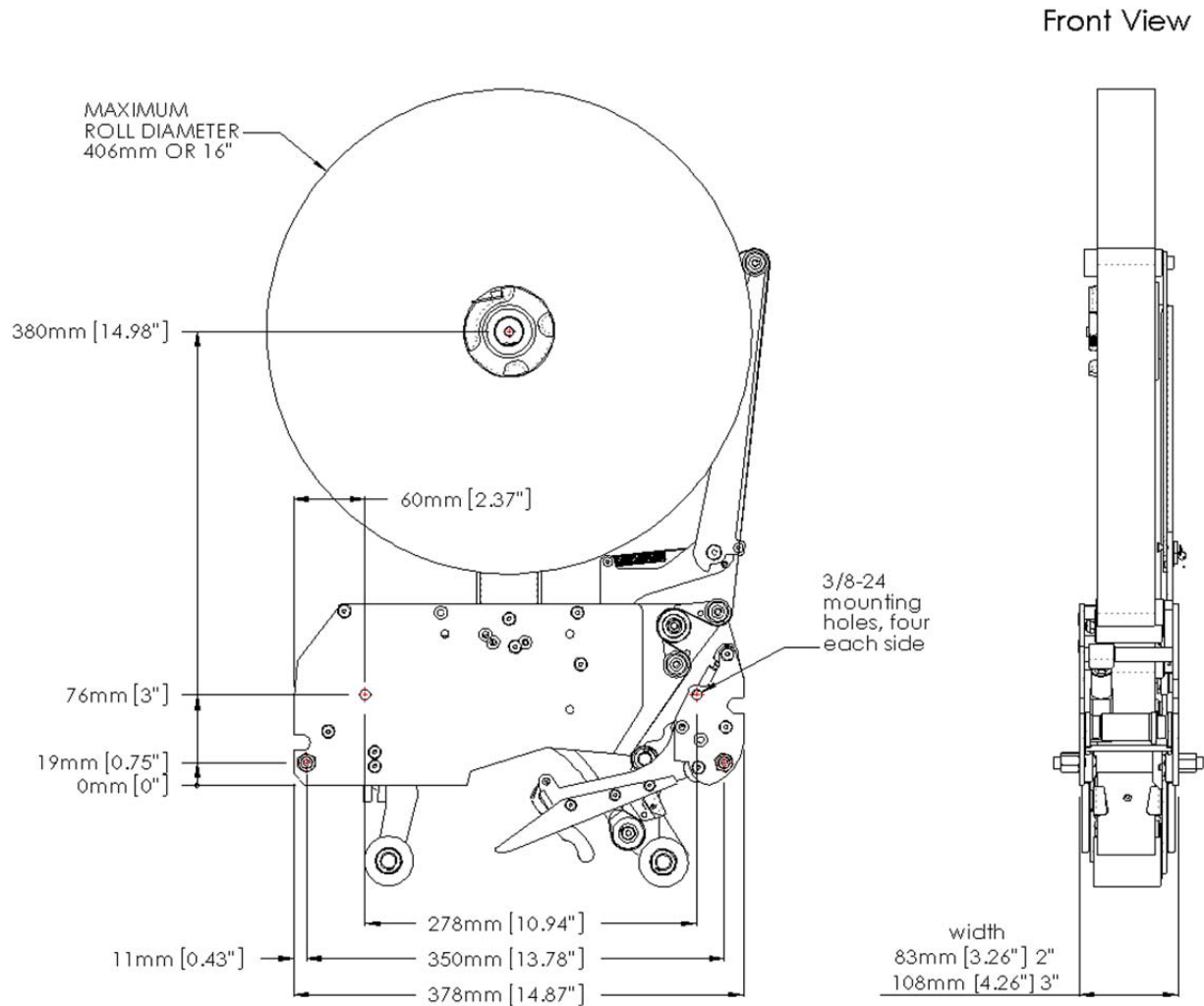

Figure 6-1

SPECIFICATIONS

Tape Head Components

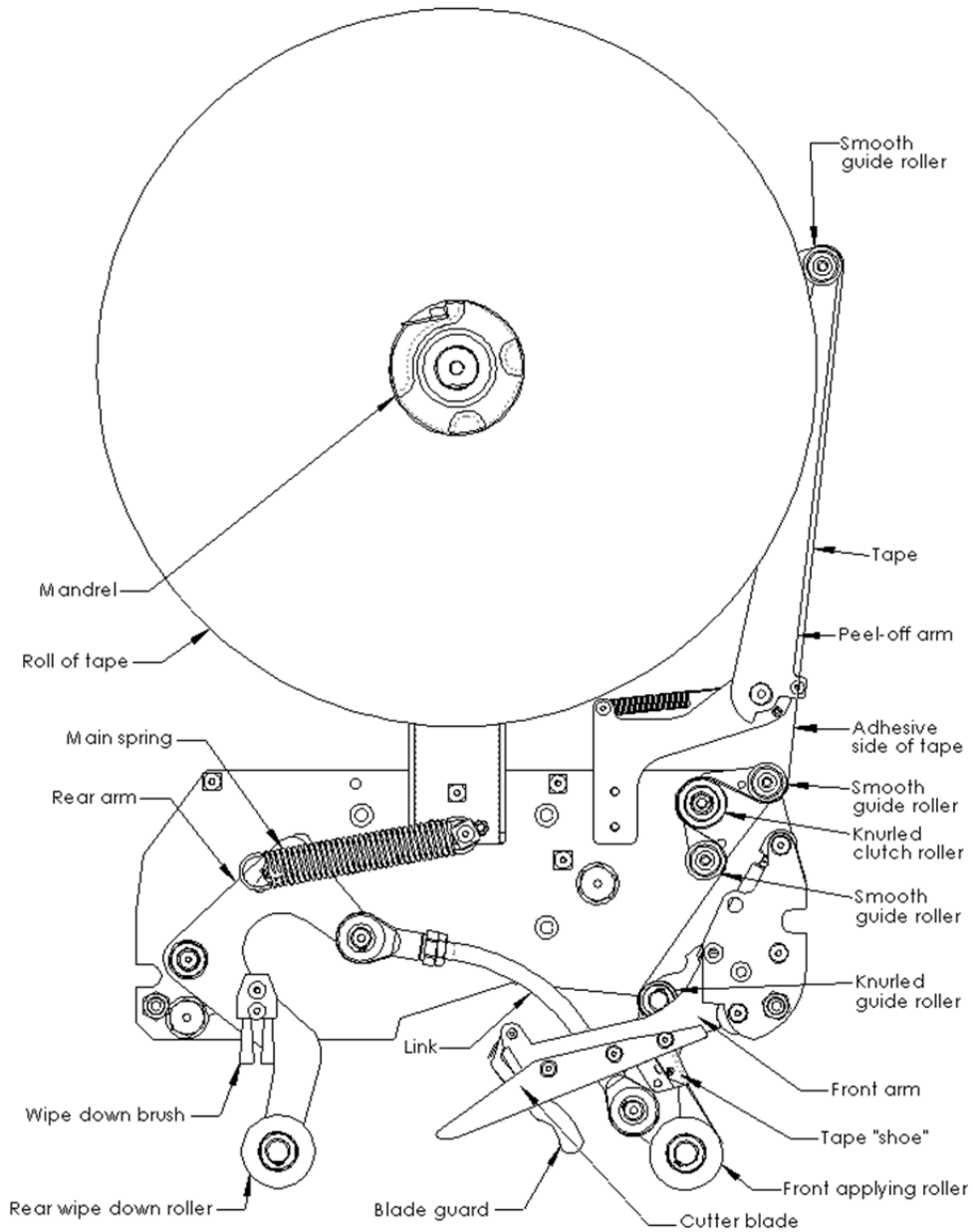

Figure 6-2

SPECIFICATIONS

Operating Conditions

Use in a dry, relatively clean environment at 40° to 105° F (5° to 40° C) with clean, dry cartons.

Note:

The HSD 2000-ET II Standard Tape Head should never be washed down or subjected to conditions causing condensation on components. HSD 2000-ET II SS Stainless Steel tape heads provide protection against mild detergent wash down only. Do not subject Stainless Steel tape heads to ANY harsh detergent or solvent wash down. The warrantee will be voided as a result.

Tape Head Specifications

1) General

Use Intertape brand Pressure Sensitive Carton Sealing Tape.

2) Tape Width

For HSD 2000-ET II 2" (48mm) models

1 ½ to 2 inch wide tape (36 to 48 mm)

For HSD 2000-ET II 3" (72mm) models

2 ½ to 3 inch wide tape (60 to 72mm)

3) Tape Roll Diameter

Maximum of 16 inches (405 mm) on a 3-inch (76.86 mm) diameter core.
(Accommodates all Intertape brand film tape machine roll lengths)

4) Tape Application Leg Length – Standard

2 ¼ inches (+0.25", -0")

57.15 mm, (+6.3 mm, -0 mm)

5) Tape Application Leg Length – Optional

The tape leg length can be adjusted from:

1 7/8 to 2 3/4 inches

47.8 mm to 69.9 mm

6) Tape Head Weight

The Tape Head weighs 13 lbs. (6.1 kg.)

7) Operating Speed

For use with line speeds up to 90 ft/min maximum.

PLEASE NOTE: A stronger main spring may be necessary to process cases at 90 ft/ min. Void filled cases should not be processed with the stronger main spring

SPECIFICATIONS

Installation Of HSD 2000-ET II In Other Machinery

This tape head can be used to upgrade case sealers provided by other manufacturers. It can be mounted in the upper or lower positions. It can also be mounted horizontally. Please contact the factory for the proper mounting adapters, any possible mirror image footprint requirements and any limitations when upgrading competitive machinery.

- 1) The case must be positively propelled through the case sealer taking into account any void fills, overfills, stability factors or weight factors.
- 2) Verify the case sizes which will be processed through the case sealer. Installing Interpack HSD 2000-ET II tape heads to process very short cases may cause the tape heads to collide with each other.
- 3) If a flight bar or lug drive system propels the case, be sure that these devices provide proper clearance and do not contact any portion of the tape head
- 4) Be sure to verify that the proper adapter kits have been ordered and supplied with the tape head.

SET-UP PROCEDURES

Receiving and Handling

All contents must be verified upon reception. The following items are included with each tape head.

DESCRIPTION	UH 175TW	UH 675TW	UH 177TW	UH 677TW
	2" WIDE PLATED	3" WIDE PLATED	2" WIDE STAINLESS	3" WIDE STAINLESS
Main Tape Head assembly	1	1	1	1
SHCS M6 x 8 (part no. UF0810)	4	4	-	-
SS SHCS M6 x 8 (parts no. UF3170)	-	-	4	4
Mounting adaptors (part no. UPH3880)	4	4	-	-
Mounting adaptors (part no. UPH3882)	4	-	-	-
Mounting adaptors (part no. UPH3881)	-	-	4	4
Mounting adaptors (part no. UPH3883)	-	-	4	-
Mounting adaptors (part no. UPH0283)	-	-	4	-
Mounting adaptors (part no. UPH0864)	4	4	-	-
Mounting adaptors (part no. UPH0282)	4	-	-	-
Main spring (part no. UPH1090)	1	1	-	-
Main spring (part no. UPH1091)	-	-	1	1
Main spring (part no. UPH0910)	1	1	1	1
Knife arm spring (part no. UPH4665)	1	1	-	-
Knife arm spring (part no. UPH7427)	-	-	1	1
Operational manual & parts list	1	1	1	1

Note: After unpacking the Tape Head, look for any damage that may have occurred during shipping. Should the Tape Head be damaged, file a claim with the transport company and notify your Intertape representative.

SET-UP PROCEDURES

WARNING! *TURN OFF ELECTRICAL POWER SUPPLY AND DISCONNECT THE POWER CORD FROM THE ELECTRICAL SUPPLY BEFORE BEGINNING TO WORK ON THE TAPE HEADS OR TO LOAD TAPE. IF POWER CORDS ARE NOT DISCONNECTED, SEVERE INJURY TO PERSONNEL COULD RESULT.*

Mounting Adapters

HSD 2000-ET II Tape Heads require **Mounting Adapter Hardware** to install in any case sealer or case erector. If your Tape Heads are pre-installed in your Interpack or TUFflex case sealer or case erector, you do not need to follow any instructions from this section. If your tape heads will be installed in any other competitive machinery, please review these general guidelines plus any additional instructions included with your HSD 2000-ET II tape head.

Location Of Mounting Adapter Holes

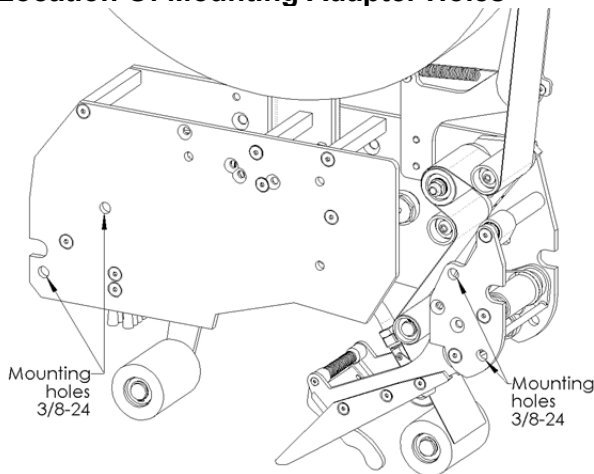

**Front Cover
Figure 7-1**

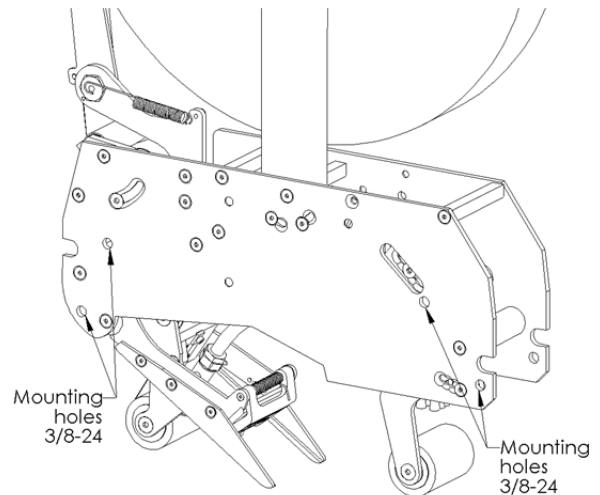

**Rear Cover
Figure 7-2**

Examples Of Mounting Hardware

There are numerous mounting holes on the front and rear side plates of the tape head. These are used to install various mounting adaptors. Examples of these mounting adaptors are:

1. Internal and external threaded nuts
2. Mounting Bars
3. Threaded Spacers

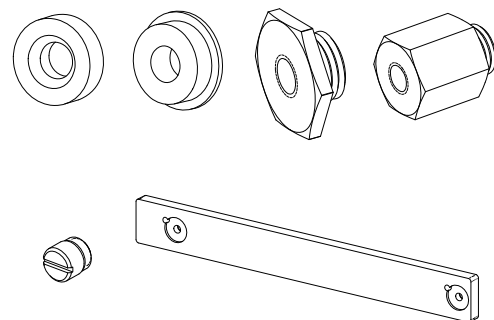

Figure 7-3

SET-UP PROCEDURES

Tape Loading

The HSD 2000-ET II Tape Heads accommodate 2-inch (48mm) wide tape rolls, while the HSD 2000-ET II/3" Tape Heads accommodate 3-inch (72mm) wide rolls.

1. Place the tape head onto a sturdy, flat surface.
2. Move the peel off roller away from the mandrel.
3. Push the roll of tape onto the mandrel with the adhesive side up (refer to **Threading Diagram** under Tape Threading section in this manual) until the core seats against the mandrel flange. This ensures the tape will be aligned when feeding into the tape head.
4. Replace the peel roller against the tape roll.

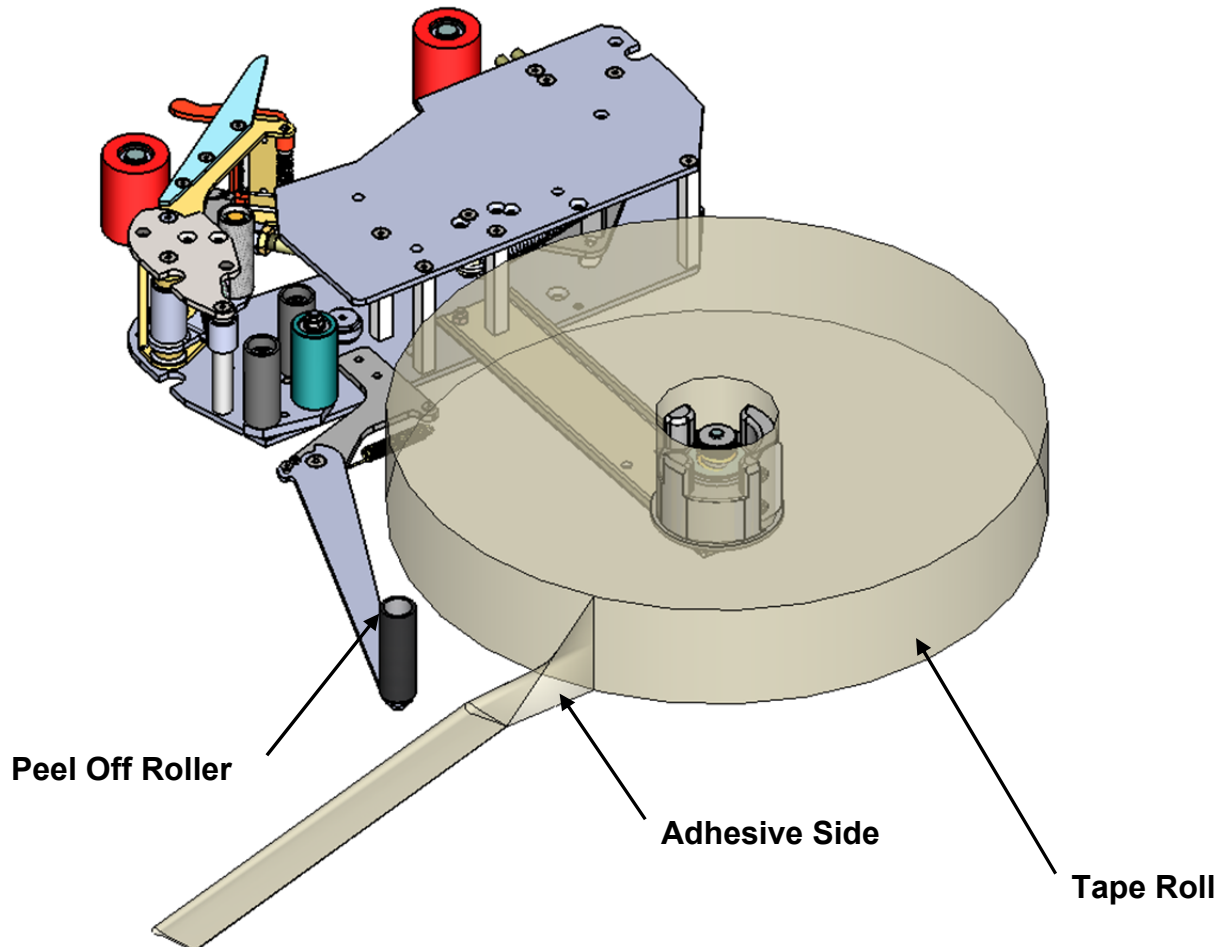

Figure 7-4

SET-UP PROCEDURES

WARNING! THE KNIFE CONTAINED IN THE TAPE HEAD IS EXTREMELY SHARP. USE CAUTION WHEN REMOVING THE BLADE GUARD AND THREADING THE TAPE TO AVOID PERSONNEL INJURY.

Tape Threading Preparation

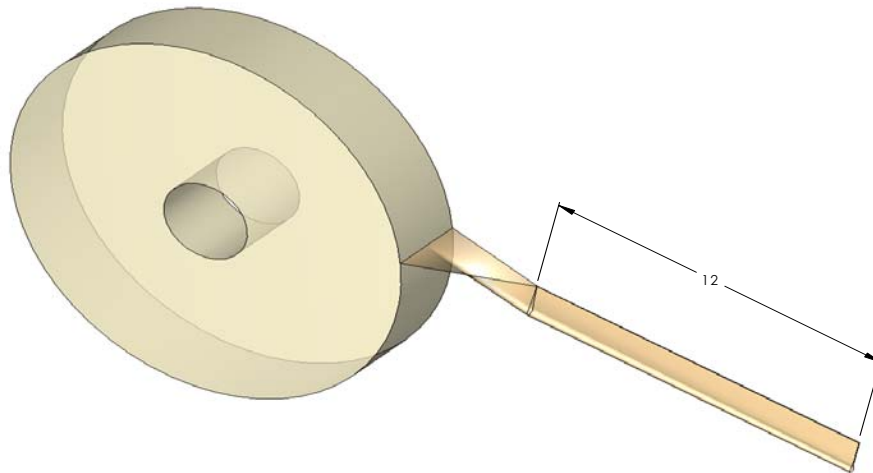

Figure 7-5

Threading the tape in the Tape Head does not require any special tools.

1. Pull approximately twelve (12) inches of tape from the roll and fold in half lengthwise, adhesive side to adhesive side. This allows you to thread the tape without it adhering to the guide and clutch rollers inside the Tape Head.

SET-UP PROCEDURES

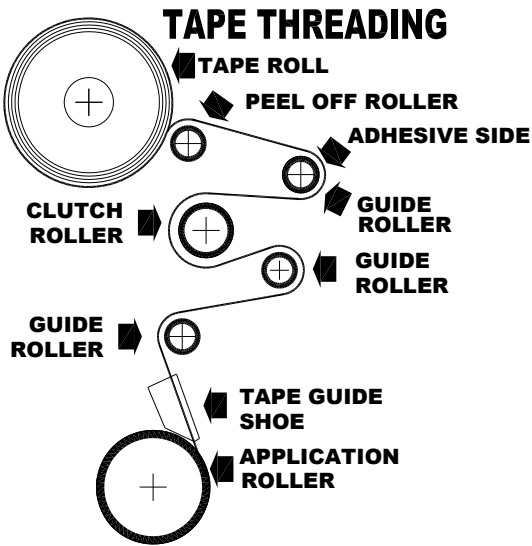

Figure 7-6

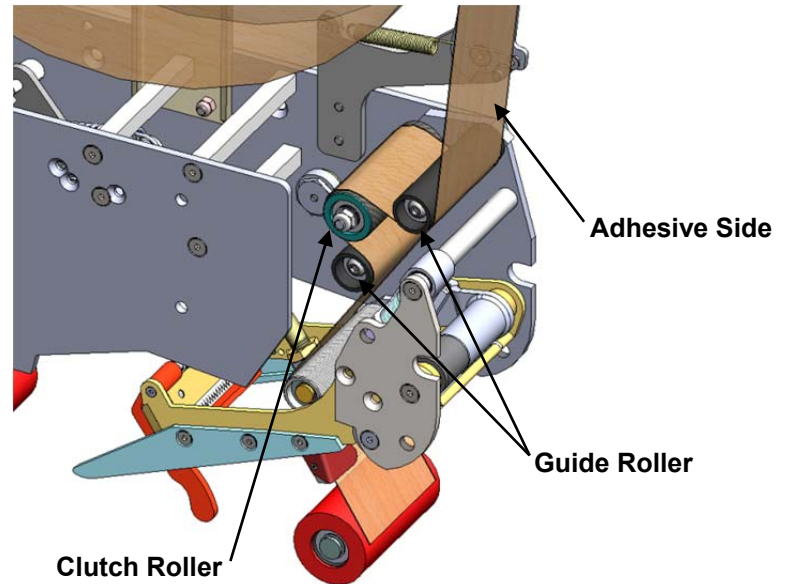

Figure 7-7

1. As illustrated in **Figures 7-6 & 7-7**, first thread the tape tail over the **Peel Off Roller**.
2. Thread the tape over and around the first “smooth” **Guide Roller**.
3. Continue to thread the tape over and around the “knurled” **Clutch Roller**.
4. Then pass the tape up and over the second “smooth” **Guide Roller**.
5. Continue threading the tape over and behind the final “knurled” **Guide Roller**.
6. Thread the tape through the cut-out provided in the **Tape Guide Shoe** and pull the tape through the front **Application Roller**, ensuring that the tape is retained in the tape guide shoe
7. Cut off the folded tape.
8. Replace the Tape Head to its initial position in the machine.

SET-UP PROCEDURES

Tape Centering

If the tape is not centered as it travels through the tape shoe guide, the tape mandrel can be adjusted in or out to correct this

Loosen the M18 inverse jam nut on the rear of the mandrel as shown in **Figure 7-8** with a 10 mm allen key.

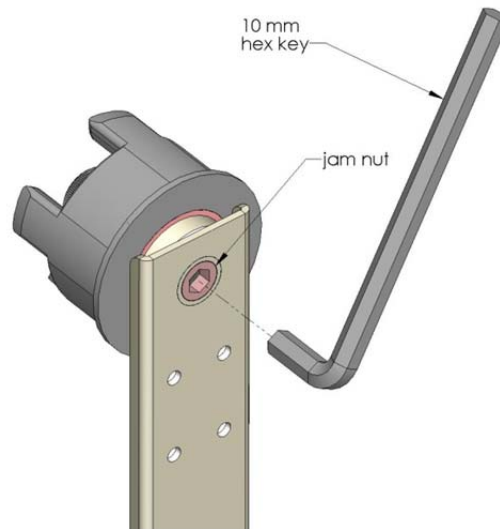

Figure 7-8

Adjust the shaft in or out as required using a flat screwdriver as illustrated in **Figure 7-9**. When the tape is centered, tighten the jam nut .

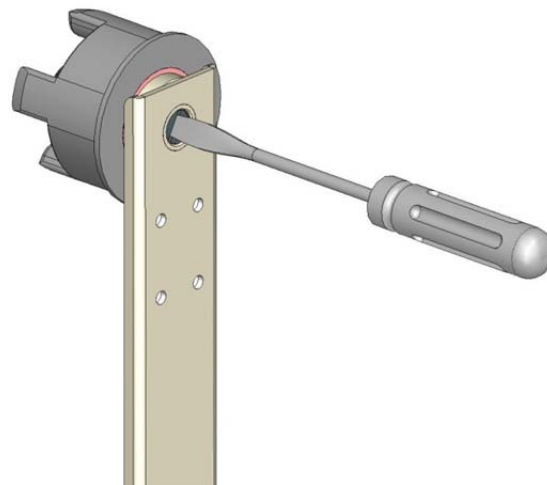

Figure 7-9

SET-UP PROCEDURES

Tape Leg Length Adjustment

For optimum performance, the tape leg length has been factory set at 2 inches (50 mm). However, the tape leg length can be modified.

Front Tape Leg

To adjust the tape leg length on the leading end of the box, refer to **Figure 7-12** of the clutch assembly. Facing the rear main frame, loosen the two (2) Flat Head Cap Screws using a 3 & 4 mm hexagonal key. Rotate the clutch assembly to bring the lowers screw towards the minus (-) sign stamped on the rear plate for a shorter tape leg. Conversely, bring the bottom screw towards the plus (+) sign for a longer tape leg. Re-tighten both Flat Head Cap Screws.

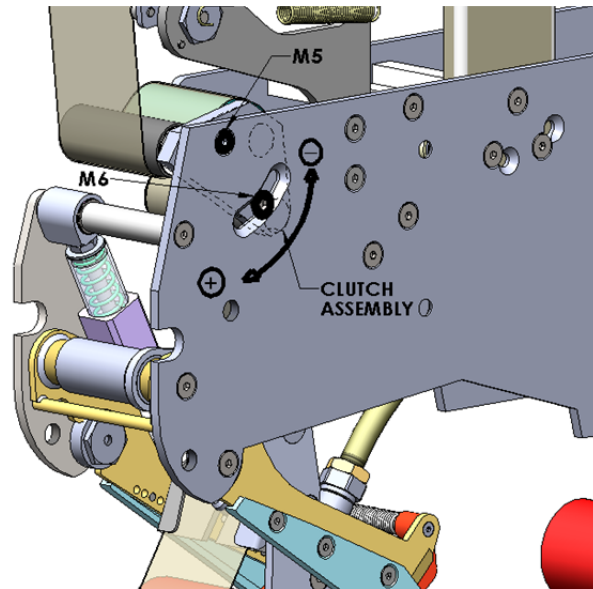

Figure 7-10

Rear Tape Leg

To adjust the tape leg length on the trailing end of the box, both chrome knife arm extension brackets must be re-positioned. Unscrew the three (3) Flat Head Cap Screws on each knife arm extension using an 2.5 mm hexagonal key. For a Shorter Tape Leg, bring the knife arm towards the front of the tape head. Conversely, for a Longer Tape Leg, bring the knife arm towards the rear of the tape head. Replace the three (3) screws on each knife arm extension and tighten.

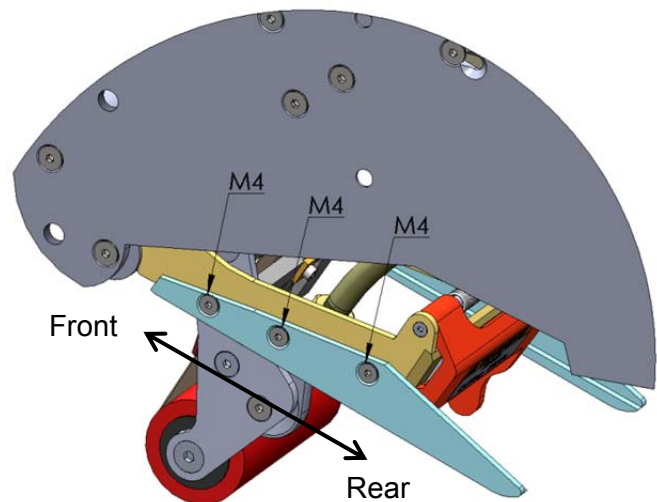

Figure 7-11

SET-UP PROCEDURES

One Way Clutched Roller Adjustment

This one direction, tensionable roller assures that proper tension is present when cutting the tape. It is preset at the factory but should re-adjustment be necessary, follow these steps:

1. Decrease all mandrel tension
2. Decrease all one way clutched roller tension
3. Process a case through the machine. It should not cut tape.
4. Gradually, apply a very small amount of tension to the one way clutched roller until a the tape is cleanly cut as the case processes
5. Too much tension will cause the tape to wrinkle or snap back
6. Too little tension will not cut the tape.

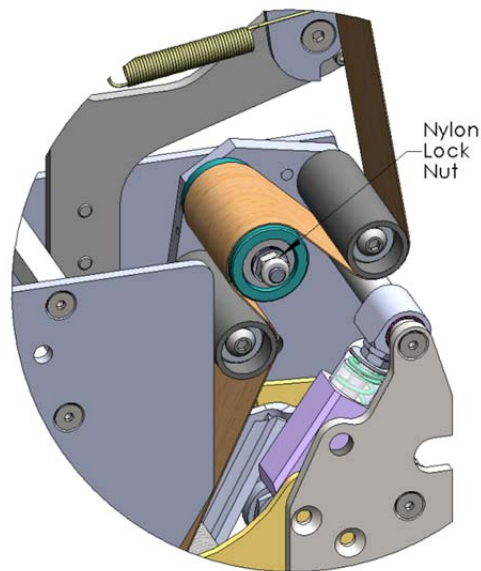

Figure 7-12

Main Spring Adjustment

The main spring tension is set at the factory. This setting should be optimal for most applications. Environments where a different setting is desirable would be:

1. Void filled cases would need a lighter wipe down pressure
2. Overfilled cases might require additional wipe down pressure
3. Double wall corrugated might need additional wipe down pressure to overcome the memory of the major flaps.
4. Thinner walled corrugated cases might require less wipe down pressure
5. Faster line speeds would need additional spring tension to provide a quicker wipe down of the rear tape leg.

Should the need arise to increase or decrease the wipe down pressure, follow these steps:

1. remove main spring (**Item #1**)
2. Loosen the flathead countersink screw (**Item # 2**)
3. Relocate to the higher hole to decrease force or to a lower hole to increase force.

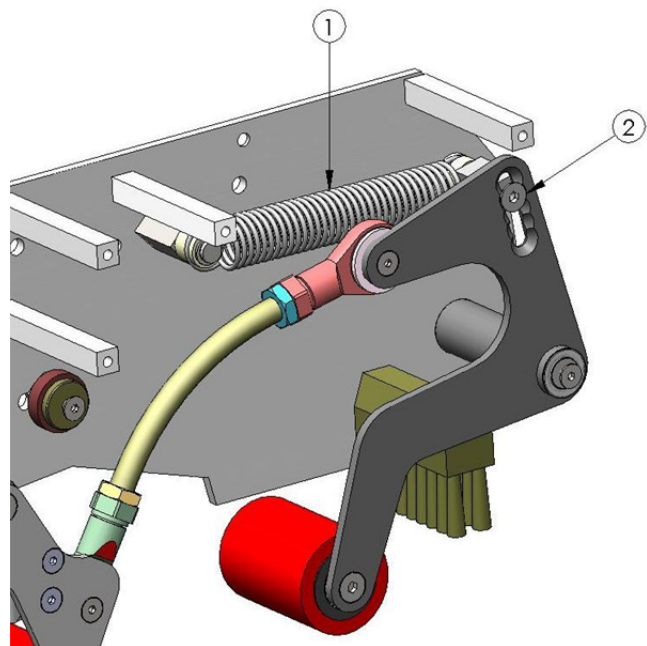

Figure 7-13

SET-UP PROCEDURES

Mandrel Tension Adjustment

Mandrel tension is required to control over spin of a full tape roll after the case is finished processing. The tension is set at the factory and no change to the tension should be necessary since the peel off roller should control the over spin in most cases.

Do not increase mandrel tension to improve tape cutting. Slightly increase the one way clutched roller to improve cutting action

Changes in mandrel tension might be required for the following reasons:

1. Larger than 1000yd (914m) are used
2. Tape head is installed on faster line speeds
3. The tape roll continues to over spin more than $\frac{1}{4}$ turn after the case leaves the tape head

Should a change in mandrel tension be required, follow these steps:

1. Observe the rotation of a full tape roll as a case processes
2. Should the tape roll continue to rotate more than $\frac{1}{4}$ turn after the case leaves the tape head, increase the adjustment nut slightly until only a small amount of rotation occurs
3. Should the tape roll rotate very little or not at all after the case leaves the tape head, decrease the adjustment nut slightly until a small amount of rotation occurs

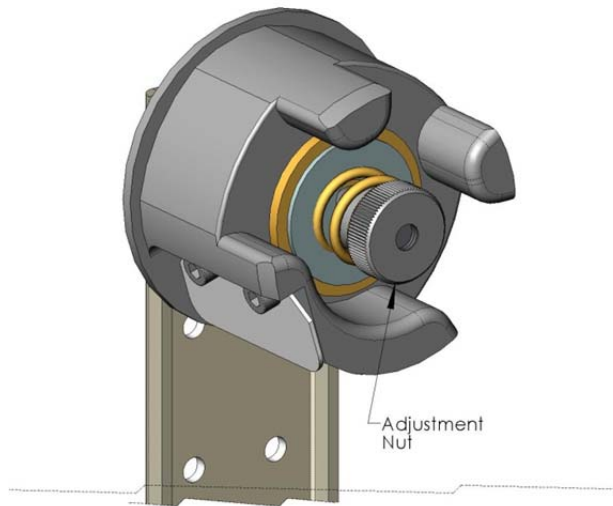

Figure 7-14

TROUBLESHOOTING

HSD 2000-ET II Tape Heads are fabricated with high quality components that provide trouble-free operation for a long period of time. However, should a problem occur, we recommend that you consult the following table. If the problem you encounter is not discussed in this table, call Interpack Technical Support. (see page 2 of this document).

TROUBLE	POSSIBLE CAUSES	SOLUTIONS
Tape does not cut cleanly.	Blade needs to be replaced.	Replace blade. Refer to preventive maintenance section for details
	Knife spring too weak or broken	Replace knife spring. Refer to preventive maintenance section for details
	One way clutched roller needs adjusting	Slightly increase the tension on the one way clutched roller
Tape Leg <i>in the tape head</i> folds up on itself	Strong air circulation (fan) is in the vicinity	Redirect airflow away from the tape head
	Spring loaded tape leg stiffener is out of position	Gently bend forward to provide a curve in the tape leg
Back tape leg does not fit tight on the box. (ripple effect)	Main spring is not strong enough	Change for the stronger main spring.(Part no. UPH3817)
	Tape applying tension is too great	Re-set tension on the mandrel and one way clutched roller

TROUBLESHOOTING CONTINUED

TROUBLE	POSSIBLE CAUSES	SOLUTIONS
<p>“Tape Tabbing” or folding on itself on the trailing tape leg</p>	<p>Generally, too much tension on the application of the tape. Follow steps below</p> <p>Applying urethane rollers, delrin guide rollers, knurled metal rollers should spin freely. Check for any adhesive migration or build up</p> <p>Too much mandrel tension</p> <p>Mandrel does not spin freely even after tension is reduced</p> <p>Too much one way clutch roller tension</p> <p>Tape unwind is difficult</p> <p>Cutter blade is dull</p>	<p>Remove any adhesive build up with silicon spray. Disassembly any non free spinning rollers and remove any adhesive build up on shafts.</p> <p>Re-set mandrel tension</p> <p>Disassemble mandrel assembly and check for any dust or adhesive build up</p> <p>Re-set clutch roller tension</p> <p>Rethread tape through the clutch roller assembly eliminating the upper roller</p> <p>Replace blade</p>
<p>Front tape leg too short</p>	<p>Generally, too much tension on the application of the tape</p> <p>Tape threaded incorrectly</p> <p>Tape leg length misadjusted</p>	<p>Follow corrective action in “Tape Flagging” section above</p> <p>Check for proper tape threading against threading diagram on side plate of tape head</p> <p>Re-set front tape leg length</p>

TROUBLESHOOTING CONTINUED

TROUBLE	POSSIBLE CAUSES	SOLUTIONS
Front tape leg too long	Tape threaded incorrectly	Check for proper tape threading against threading diagram on side plate of tape head
	Tape leg length misadjusted	Re-set front tape leg length
Rear tape leg too short	Generally, too much tension on the application of the tape	Follow corrective action in “ Tape Flagging ” section above
	Tape threaded incorrectly	Check for proper tape threading against threading diagram on side plate of tape head
	Tape leg length misadjusted	Re-set front tape leg length
Rear tape leg too long	Tape threaded incorrectly	Check for proper tape threading against threading diagram on side plate of tape head
	Tape leg length misadjusted	Re-set front tape leg length
Tape not centered on the center seam of the case	Tape Head mandrel not centered	Readjust mandrel so tape is centered on the case

RECOMMENDED SPARE PARTS LIST

We recommend that you stock the following spare parts. These parts are contained in the “spare parts kit” indicated below. The components of the spare parts kits are also referenced should individual components need to be ordered.

HSD 2000-ET II Standard 2” Wide Spare Parts Kit UH1002

Parts Contained in UH 1002 Spare Parts Kit			
MODEL NUMBER	DESCRIPTION	ITEM NUMBER	QUANTITY
	Roller shell ETM	UPH0775	2
	Ext. spring, light	UPH0910	1
	Ext. main spring	UPH1090	1
	Knife guard spring	UPH9099	1
	Brush ETM	UPH3655	1
	Cut-off blade 48mm, NC	UPH0193	1
	Knife arm spring	UPH9147	1
	Torsion spring	UPH9195	1
	Compression Spring	UPH4665	1
	SS Main Spring ETM.080	UPH1091	1

HSD 2000-ET II Standard 3” Wide Spare Parts Kit UH 1003

Parts Contained in UH 1003 Spare Parts Kit			
MODEL NUMBER	DESCRIPTION	ITEM NUMBER	QUANTITY
	Roller shell ETM 3”	UPH0966	2
	Ext. spring, light	UPH0910	1
	Ext. main spring	UPH1090	1
	Knife guard spring	UPH9195	1
	Brush ETM 3”	UPH3674	1
	Cut-off blade 75mm, NC	UPH0271	1
	Knife arm spring	UPH9147	1
	Torsion spring	UPH9195	1
	Compression Spring	UPH4665	1
	SS Main Spring ETM.080	UPH1091	1

PREVENTIVE MAINTENANCE

WARNING! TURN OFF ELECTRICAL POWER SUPPLY AND DISCONNECT THE POWER CORD FROM THE ELECTRICAL SUPPLY BEFORE BEGINNING TO WORK ON THE TAPE HEADS OR TO LOAD TAPE. IF POWER CORDS ARE NOT DISCONNECTED, SEVERE INJURY TO PERSONNEL COULD RESULT.

The HSD 2000-ET II has been designed and manufactured with the finest components to provide long, trouble free performance. General preventive maintenance will improve performance and prolong the life of the tape head

Please review the illustration and chart below for information regarding tape head maintenance

Knife Blade Replacement

The knife blade is made from hardened steel and should provide a minimum of 250,000 cycles before replacement.

The cut-off blade is locked in position with two (2) M5 Button Head Cap Screws. To replace the cut-off blade:

1. Loosen both screws with a 3 mm hexagonal key. Do not remove the screws
2. Remove the blade by sliding out.
3. Insert the new blade with the bevel facing away from the front wipe down roller
4. Ensure the blade bottoms against the screws and tighten securely

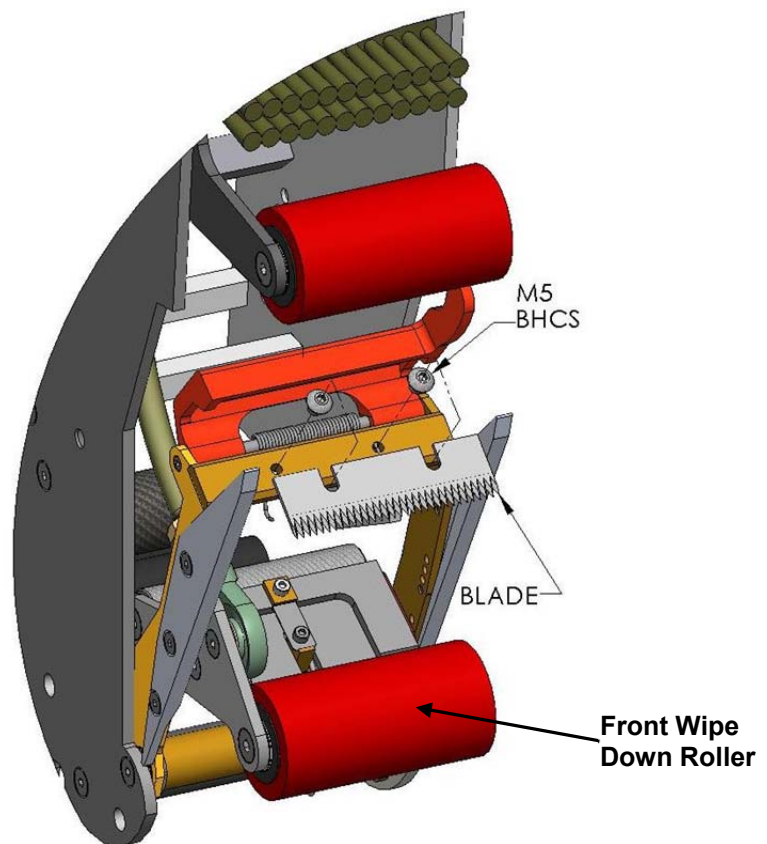

Figure 10-1

PREVENTIVE MAINTENANCE

Lubrication

The HSD 2000-ET II tape heads ship from the factory permanently lubricated. No additional lubrication is necessary, however, a small amount of lightweight oil applied to rotating and pivot points will extend the life of the tape head and assure maximum performance.

There is, however a felt pad on the blade guard which can serve as an oiler pad to help clean the blade should adhesive accumulate. At regular intervals, depending on usage, add a small amount of lightweight oil or silicon spray so that when a case is processed, the oil from the pad is transferred to the blade as the knife guard is opened and closed.

Oiler Pad Lubrication

WARNING: USE CAUTION WHEN OILING THIS PAD AS THE CUTTER BLADE IS VERY SHARP

1. Retract the blade guard using the extension tab as a handle
2. Remove any debris or accumulated adhesive build up
3. Apply a liberal amount of either lightweight oil or silicon lubricant to the pad.
4. Carefully replace the blade guard against the blade

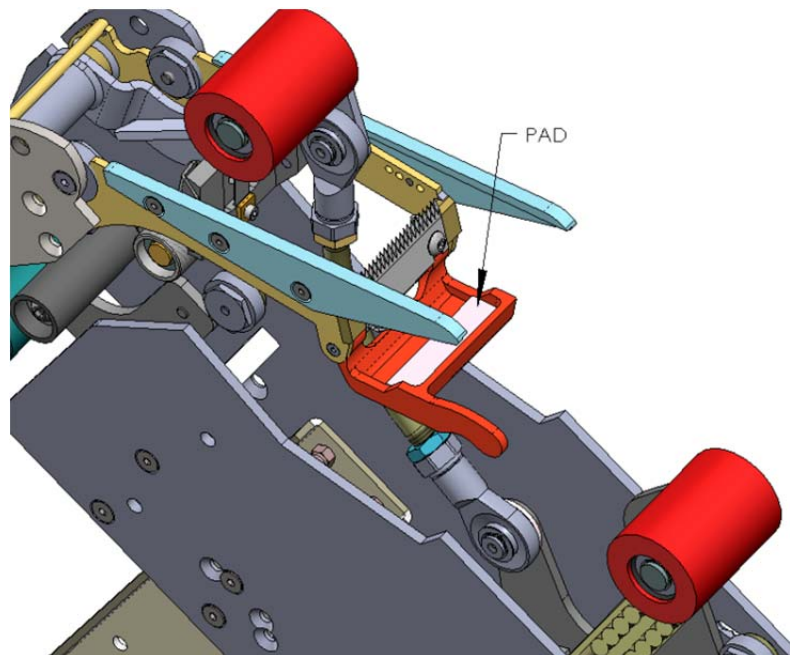

Figure 10-2

PREVENTIVE MAINTENANCE

Urethane Wipe Down Roller Replacement

These red rollers are wear items and should be inspected regularly and replaced if necessary.

Front & Rear Wipe Down Roller Replacement

Removing The Urethane Roller

1. Using a snap ring pliers, remove the snap ring from the roller shaft.
2. Remove the flat washer and spring washer.
3. Remove the front applying roller and hub
4. With a sharp utility knife, cut away the red urethane roller from its mounting hub

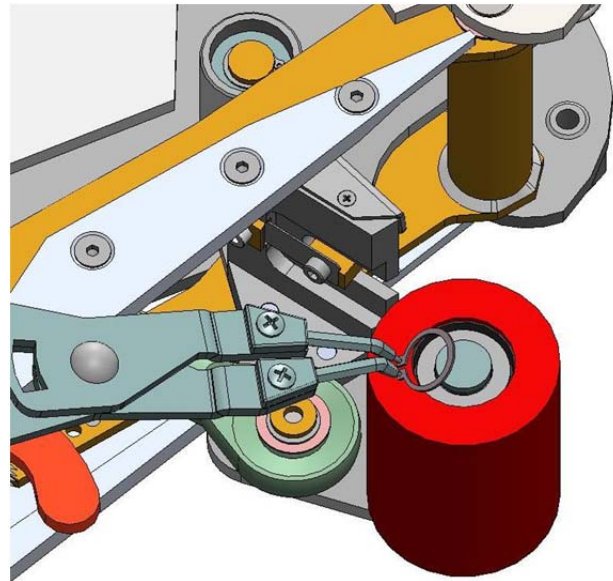

Figure 10-5

Installing The New Urethane Roller

1. Feed the new roller onto the end of the hub edge without the raised shoulder
2. Press the new roller all the way down to the end of the hub and against the raised shoulder
3. Reinstall the roller & hub onto the roller arm shaft with the raised shoulder away from you
4. Replace the spring washer and flat washer
5. Replace the snap ring
6. Refer to the assembly drawing found later in this manual for proper sequence of assembly

NOTE: If the roller is too difficult to slide onto the hub, submerge it in hot water for about 1 minute. This will soften the material to allow easier assembly

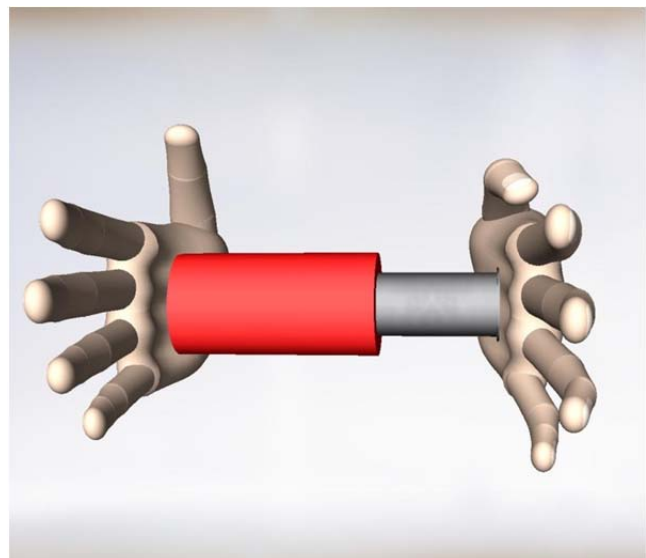

Figure 10-6

PREVENTIVE MAINTENANCE

Spring Replacements

There are 3 springs on the HSD 2000-ET II. These springs are wear items and should be inspected regularly and replaced if necessary. Below are instructions for replacing the two most common springs.

Main Spring Replacement

1. Using a pair of needle nose pliers, remove one end of the main spring from the retainer ring.
2. Take off the damaged spring.
3. Hook one end of the new spring over the retaining ring in the middle.
4. Stretch the spring over rear arms spring retainer ring using either needle nose pliers or your finger. Hook the loop securely into the retainers groove.

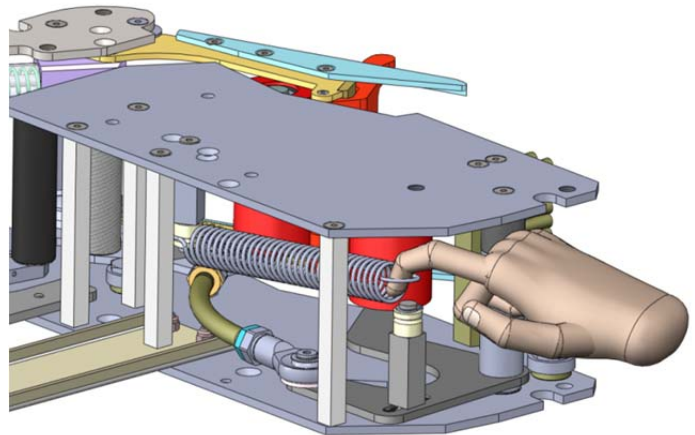

Figure 10-7

Knife Arm Spring Adjustment

Should the **Knife Arm Cutting Force** need to be adjusted, follow the procedure below.

1. To increase the force, using a 10mm open end wrench, turn the 6mm nut clockwise until desired pressure achieved. Lock into the new position with the second nut.
2. To decrease the force, using a 10mm open end wrench loosen lock nut first. Turn it counter clockwise. Follow up with the first nut counter clockwise as well, till it is locked into the new position.

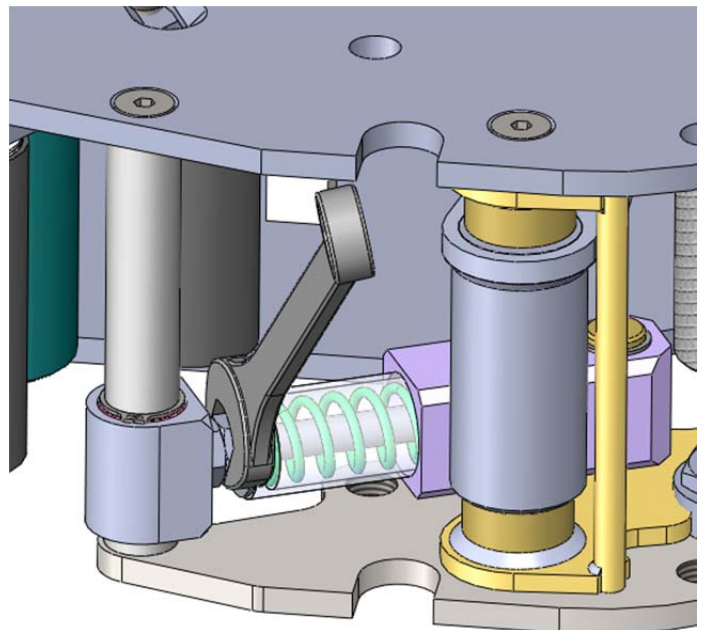

Figure 10-8

Knife Arm Spring Replacement

If the compression spring breaks, the sequence to change it is as follows.

1. Carefully open the snap ring with a plier and slide it up on the cross shaft. Remove the snap ring attached to the knife arm assembly. (Wear safety glasses while working with retaining rings).

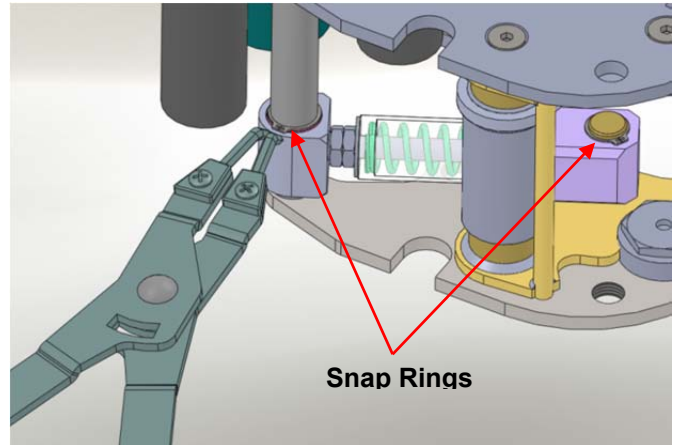

Figure 10-9

2. Slide off the repulsive pivot assembly from current position as shown in Figure 10-10.

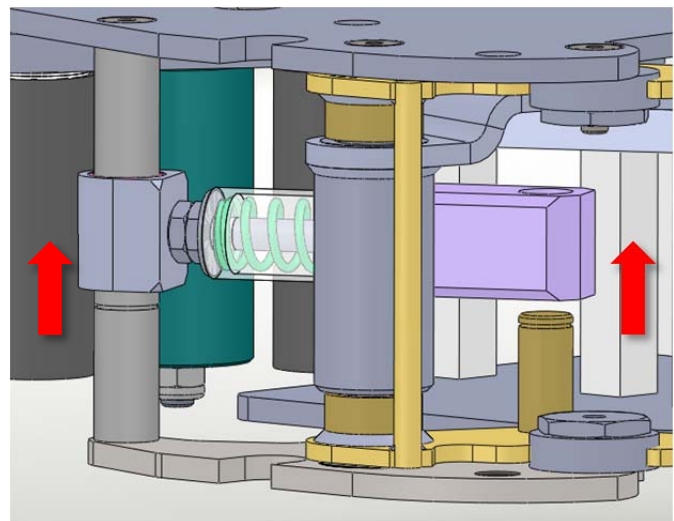

Figure 10-10

3. Remove the spring barrel from overlapping position as shown in Figure 10-11. Remove any broken particle from the spring guide. Install new compression spring into the captive position.

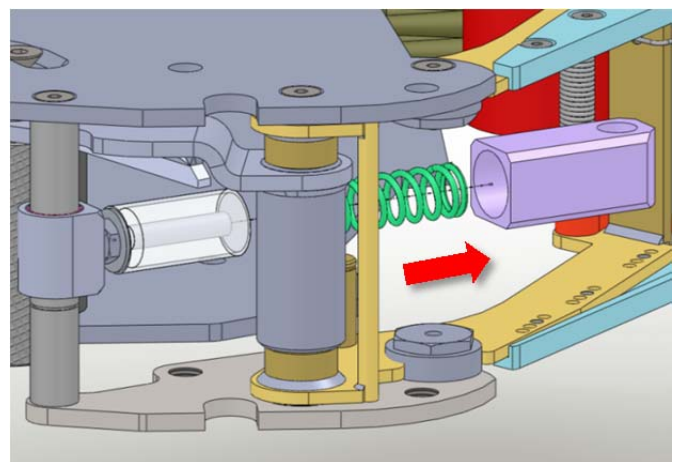

Figure 10-11

4. Press the spring barrel against the spring mandrel until it is ready to slide back on the short shaft. See Figure 10-12. Move the whole sub assembly back to its original position.

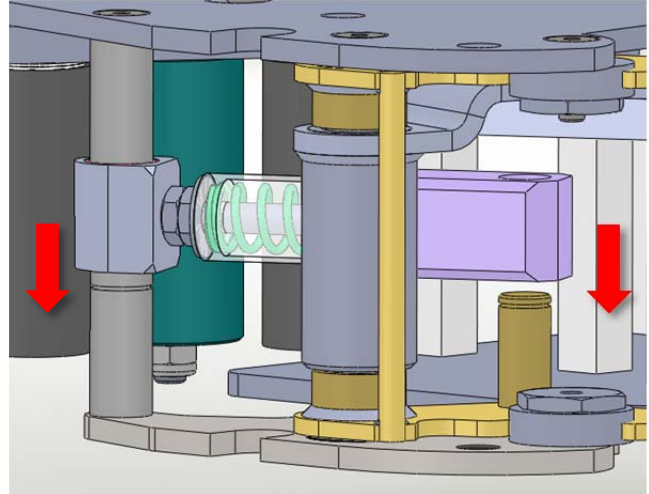

Figure 10-12

5. Reinsert retaining rings to their grooves. Should the 12 mm retaining ring brake (left one on Figure 10-13), the shaft needs to be freed to replace it. Calibrate spring pressure with the M6 nuts as described earlier.

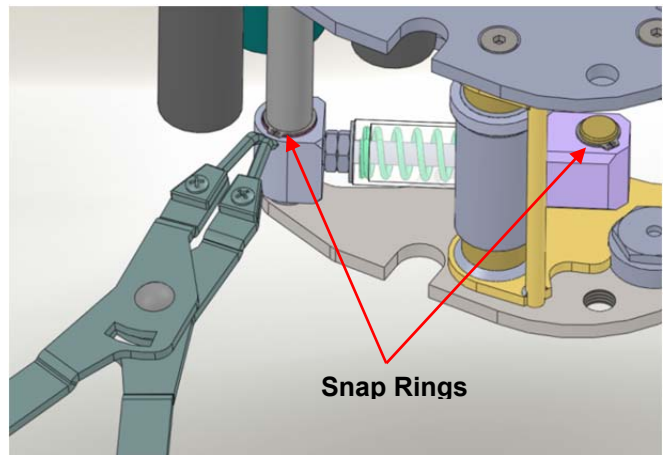

Figure 10-13

Knife Guard Spring Replacement

As a precaution, remove the cutter blade to avoid injury

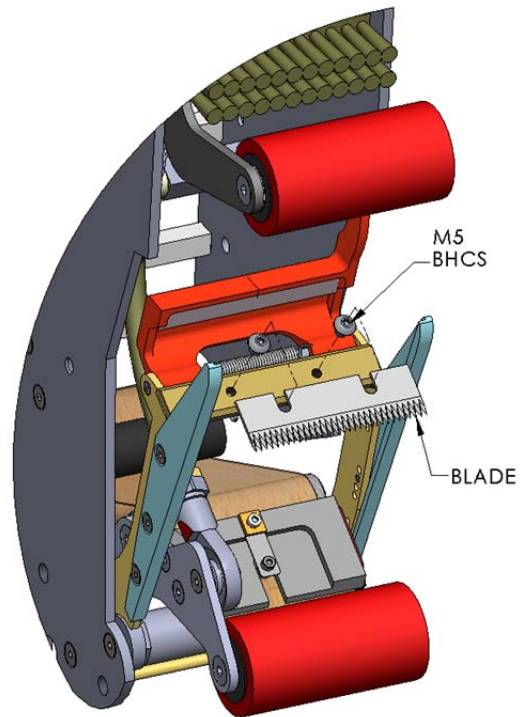

Figure 10-14

Remove the cross shaft

NOTE: These screws are secured with loctite and may require applied heat prior to removal

1. Using *two* 2mm hexagonal keys as shown, remove *one* of the flathead countersink screws by applying force on both hexagonal key in an attempt to remove each screw.
2. Once one of the screws breaks free, only continue to remove that screw.
3. Leave the remaining flathead countersink screw that did not yield attached to the cross shaft

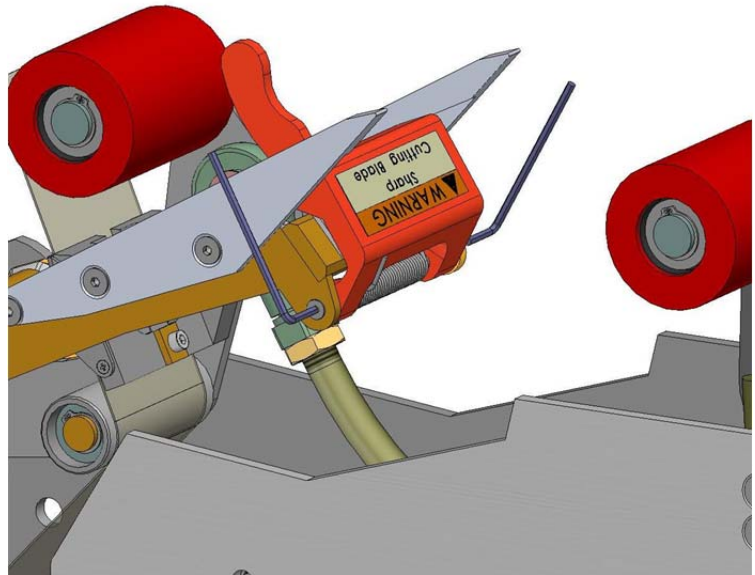

Figure 10-15

PREVENTIVE MAINTENANCE

Carefully slide out the shaft from the end of the shaft that contains the remaining flathead countersink screw

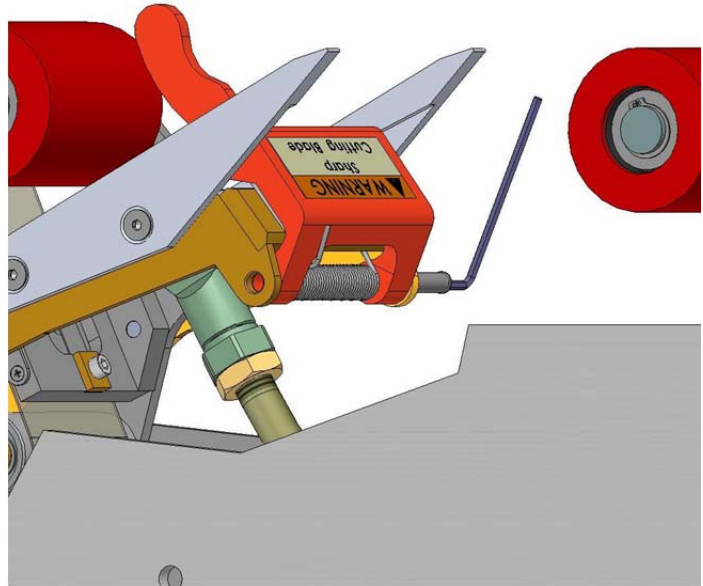

Figure 10-16

Remove the broken spring

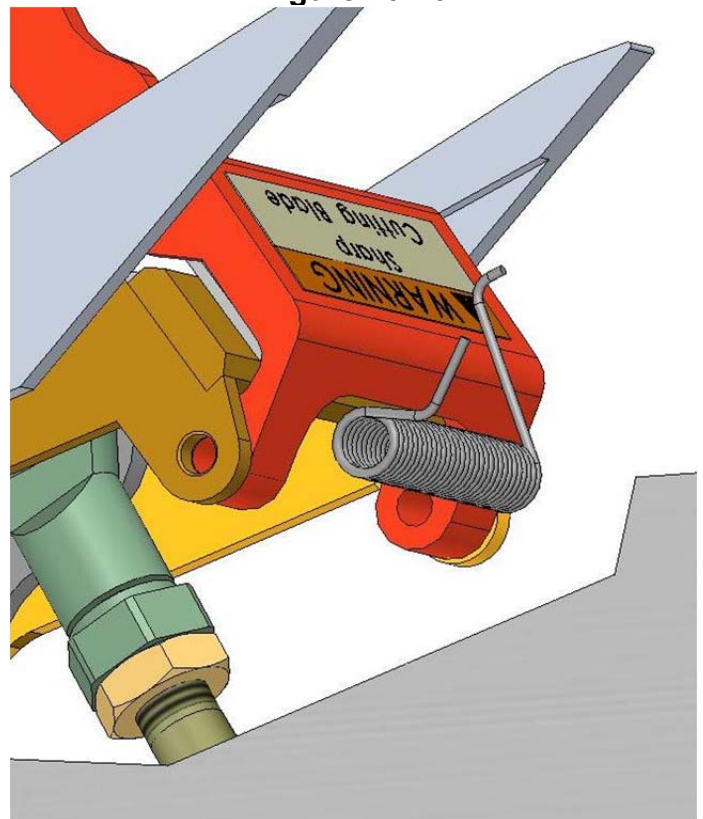

Figure 10-17

PREVENTIVE MAINTENANCE

To properly orient the new knife spring

1. Position the new knife spring as shown in **Figure 10-18**.
2. Note which leg of the spring should lie behind the cutter blade mounting plate
3. Note which leg of the spring should wrap around the front of the knife guard

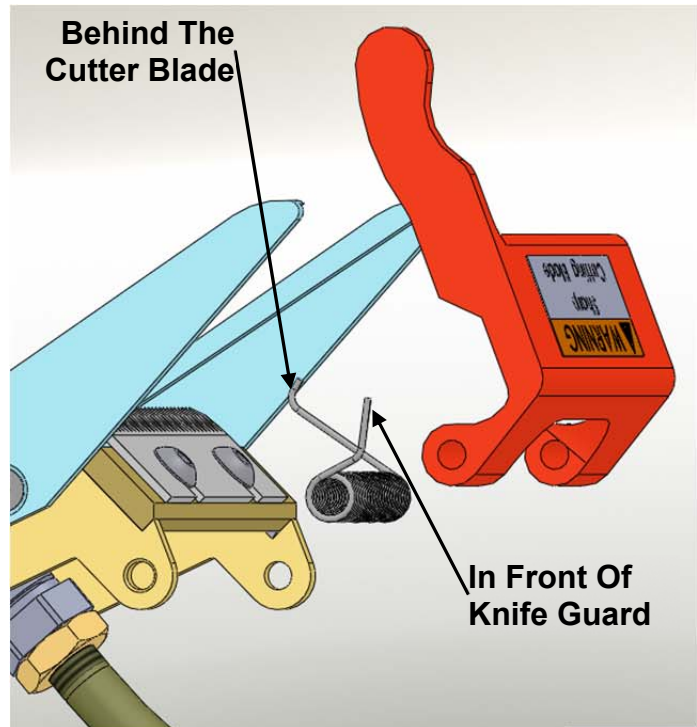

Figure 10-18

Insert the cross shaft through the knife arm, knife guard and knife guard spring as shown in **Figure 10-19**

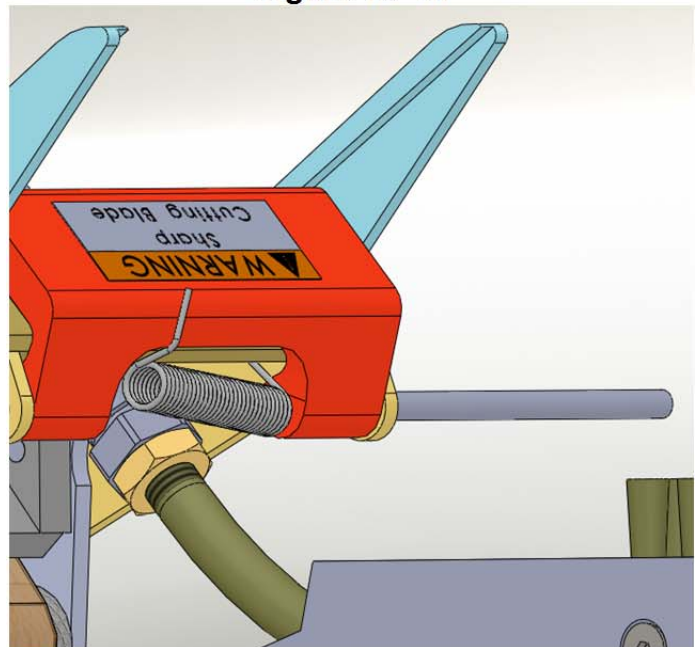

Figure 10-19

PREVENTIVE MAINTENANCE

To Complete The Installation

1. Apply some Blue Loctite to the threads of the M3 screw and fasten to the end of the cross shaft. Tighten using two 2mm hexagonal keys as shown in Figure 10-20
2. Rotate the knife guard to make sure there is no binding
3. Re-install the cutter blade as shown in Figure 10-14
4. Inspect the oiler pad to make sure it is securely fastened. Clean the pad and apply some lightweight oil.

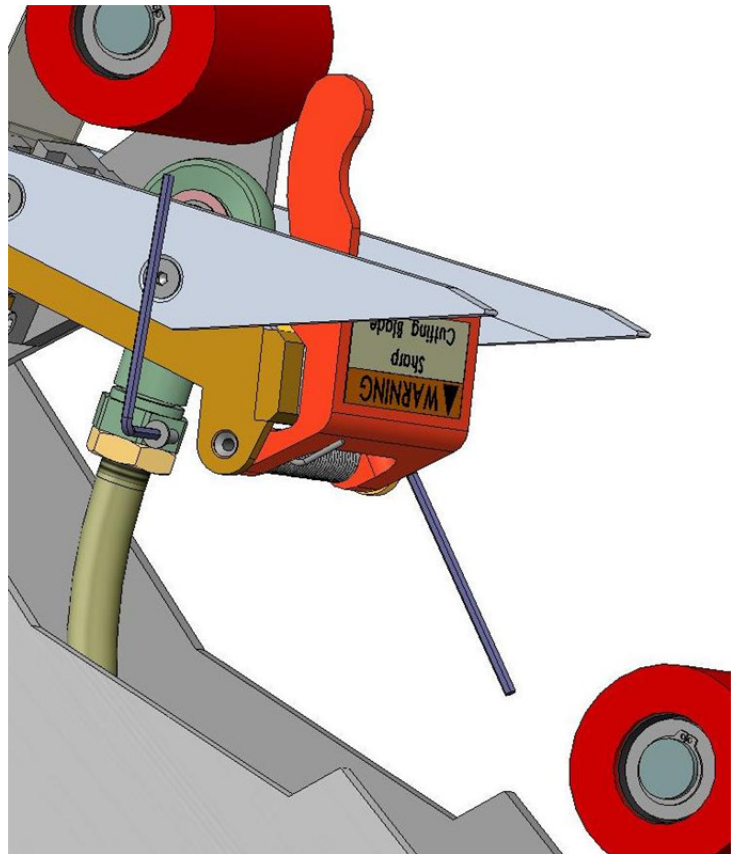

Figure 10-20

PREVENTIVE MAINTENANCE

Wipe Down Brush Replacement

This multi row brush assists in wiping down the top center seam of the case. While the red wipe down rollers perform much of the wipe down, the wipe down brush enhances the wipe down as it can better conform to the irregularities of the top of the case such as over fills, void fills and the “wash-board” effect of thinner walled corrugated.

Over time, this brush can become distorted or worn and should be replaced.

Wipe Down Brush Replacement

1. Remove 2 M5 flathead countersink screws (**Item #1**) from the operator side panel using a 3 mm hex key
2. Remove the brush (**Item #2**)
3. Install new brush with 2 M5 flathead countersink screws as shown in **Figure 10-21**

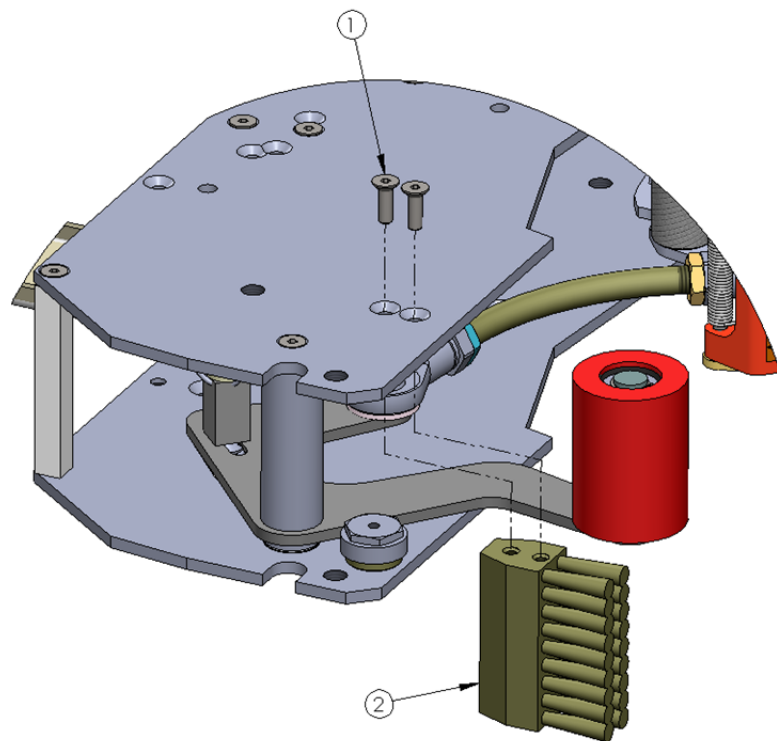

Figure 10-21

SCHEDULE OF PREVENTIVE MAINTENANCE

Item	Action Required	Material	Frequency		
			Weekly	Monthly	Quarterly
Blade Guard Oiler Pad	Lubricate	Lightweight oil	X		
Hardware	Re-tighten any loose hardware				X
	Replace any missing hardware				X
Cutter Blade	Inspect for wear		X		
	Clean	Solvent Cleaner	X		
Mandrel Assembly	Disassemble & Observe				X
Mandrel Spring	Check for weakness	None			X
Mandrel Friction Washer	Clean	Solvent Cleaner			X
Mandrel Metal Washer	None	None			X
Mandrel Shaft	Remove any dust and adhesive build up	Solvent Cleaner			X
Mandrel Bearing	Check for wear	None			X
Peel Roller					X
Delrin Roller	Check for free spinning. Disassemble and remove any adhesive build up.	Solvent Cleaner			X
Pivot Shaft	Check for any restriction	Solvent Cleaner			X
Peel Roller Spring	Check for weakness				X
Plastic Guide Rollers	Check for free spinning. Disassemble and remove any adhesive build up.	Solvent Cleaner		X	
Knurled PTFE Coated One Direction Clutch Roller	Back off tension. Check for free spinning. Disassemble and remove any adhesive build up.	Solvent Cleaner		X	
Knurled PTFE Coated Guide Roller	Rotation should be slightly restricted by Belville washer. Disassemble and remove any adhesive build up if excessive restriction is detected	Solvent Cleaner		X	
Front Red Wipe Down Roller	Rotation should be slightly restricted by Belville washer. Disassemble and remove any adhesive build up if excessive restriction is detected	Solvent Cleaner		X	
Rear Red Wipe Down Roller	Check for free spinning. Disassemble and remove any adhesive build up.	Solvent Cleaner		X	
Main Spring	Remove and inspect for any wear or weakness. Replace as necessary.			X	
Knife Spring	Remove and inspect for any wear or weakness. Replace as necessary.			X	
Tape Shoe Guide Flat Spring	Inspect for any wear or weakness. Replace as necessary.			X	
Wipe Down Brush	Inspect for any wear or weakness. Replace as necessary.			X	
Main Applying And Wipe Down Assembly	Remove <i>Main Spring</i> and check for any restrictions when assembly is in motion	Worn bearings, bent shafts, bent roller arms			X
Knife Arm Assembly	Remove <i>Knife Spring</i> and check for any restrictions when assembly is in motion	Worn bearings, bent shafts, bent roller arms			X

Refer To Assembly Drawings For Part Numbers Of Replacement Parts If Required

APPENDIX A – ILLUSTRATIONS & PARTS LISTS

Tape Head Sub-assemblies	. 42
Main Frame Sub-assemblies	. 44
Front Cover Frame Sub-assemblies	. 46
Rear Cover Frame Sub-assemblies 48
Rear Arms	. 50
Clutch Assembly..... 52
Mandrel Assembly	... 54
Peel-off Arm Assembly 56
Link Assembly 58
Front Arms	60
Knife Arms	64
Repulsive Pivot Assembly	. 66
No Tape Sensor (Option).	. 68
Low Tape Sensor (Option)..	. 70

THIS PAGE INTENTIONALLY BLANK

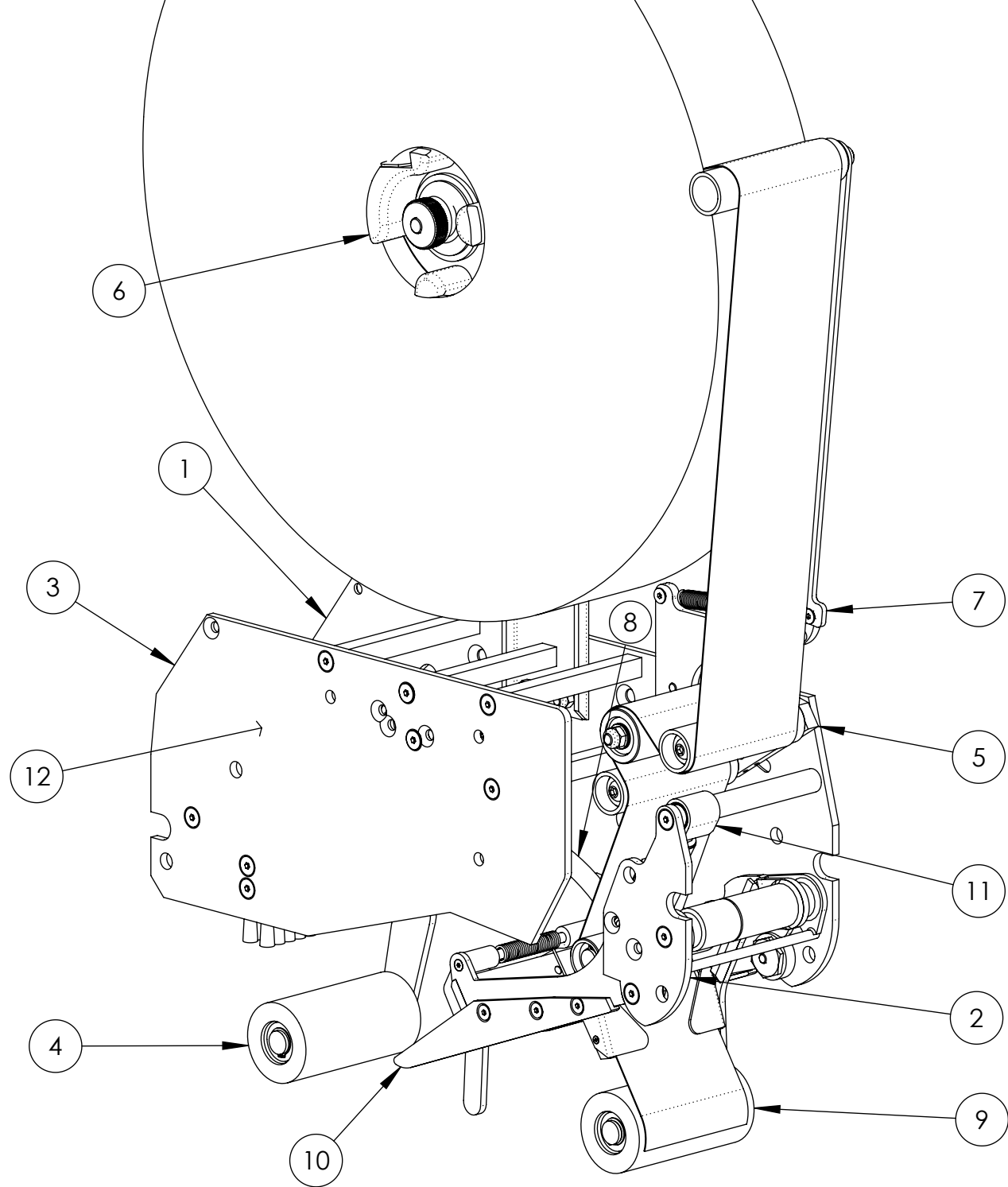

ITEM	PART #	DESCRIPTION	UH175T 2"/QTY.	UH675T 3"/QTY.	UH177T 2"SS/QTY.	UH677T 3"SS/QTY.
1	USH1033	MAIN FRAME 48 ET 2.5	1	-	-	-
1	USH1034	MAIN FRAME 72 ET 2.5	-	1	-	-
1	USH1060	MAIN FRAME 2" SS	-	-	1	-
1	USH1061	MAIN FRAME 3" SS	-	-	-	1
2	USH1035	FRONT COVER FRAME	1	1	-	-
2	USH1036	FRONT COVER FRAME SS	-	-	1	1
3	USH7019	REAR COVER FRAME 48	1	-	-	-
3	USH7020	REAR COVER FRAME 72	-	1	-	-
3	USH7021	REAR COVER FRAME 48 SS	-	-	1	-
3	USH7022	REAR COVER FRAME 72 SS	-	-	-	1
4	USH0774	REAR ARM ET II 48	1	-	-	-
4	USH0786	REAR ARM ET II 72	-	1	-	-
4	USH0872	REAR ARM ET II SS 48	-	-	1	-
4	USH0881	REAR ARM ET II SS 72	-	-	-	1
5	USH0775	CLUTCH ASS'Y 48	1	-	-	-
5	USH0787	CLUTCH ASS'Y 72	-	1	-	-
5	USH0870	CLUTCH ASS'Y 48 SS	-	-	1	-
5	USH0879	CLUTCH ASS'Y SS 72	-	-	-	1
6	USH1008	MANDREL ASS'Y ET TW 48	1	-	-	-
6	USH1009	MANDREL ASS'Y ET TW 72	-	1	-	-
6	USH1010	SS MANDREL ASS'Y ET TW 48	-	-	1	-
6	USH1011	SS MANDREL ASS'Y ET TW 72	-	-	-	1
7	USH0768	PEEL OFF ARM ASS'Y 48	1	-	-	-
7	USH0886	PEEL OFF ARM ASS'Y 72	-	1	-	-
7	USH0883	SS PEEL OFF ARM ASS'Y 48	-	-	1	-
7	USH0884	SS PEEL OFF ARM ASS'Y 72	-	-	-	1
8	USH0939	LINK ASS'Y ET II	1	1	1	1
9	USH0521	FRONT ARM 48	1	-	-	-
9	USH1030	FRONT ARM 72	-	1	-	-
9	USH1031	FRONT ARM 48 SS	-	-	1	-
9	USH1032	FRONT ARM 72 SS	-	-	-	1
10	USH0522	KNIFE ARM	1	-	-	-
10	USH0524	KNIFE ARM 72	-	1	-	-
10	USH3851	KNIFE ARM 2" SS	-	-	1	-
10	USH3852	KNIFE ARM 3" SS	-	-	-	1
11	USH1057	REPULSIVE PIVOT ASS'Y	1	1	-	-
11	USH1058	REPULSIVE PIVOT ASS'Y SS	-	-	1	1
12	UPH0910	SS EXT. SPRING	1	1	1	1
13	UPH1091	MAIN SPRING ETM SS	1	1	1	1

MAIN FRAME

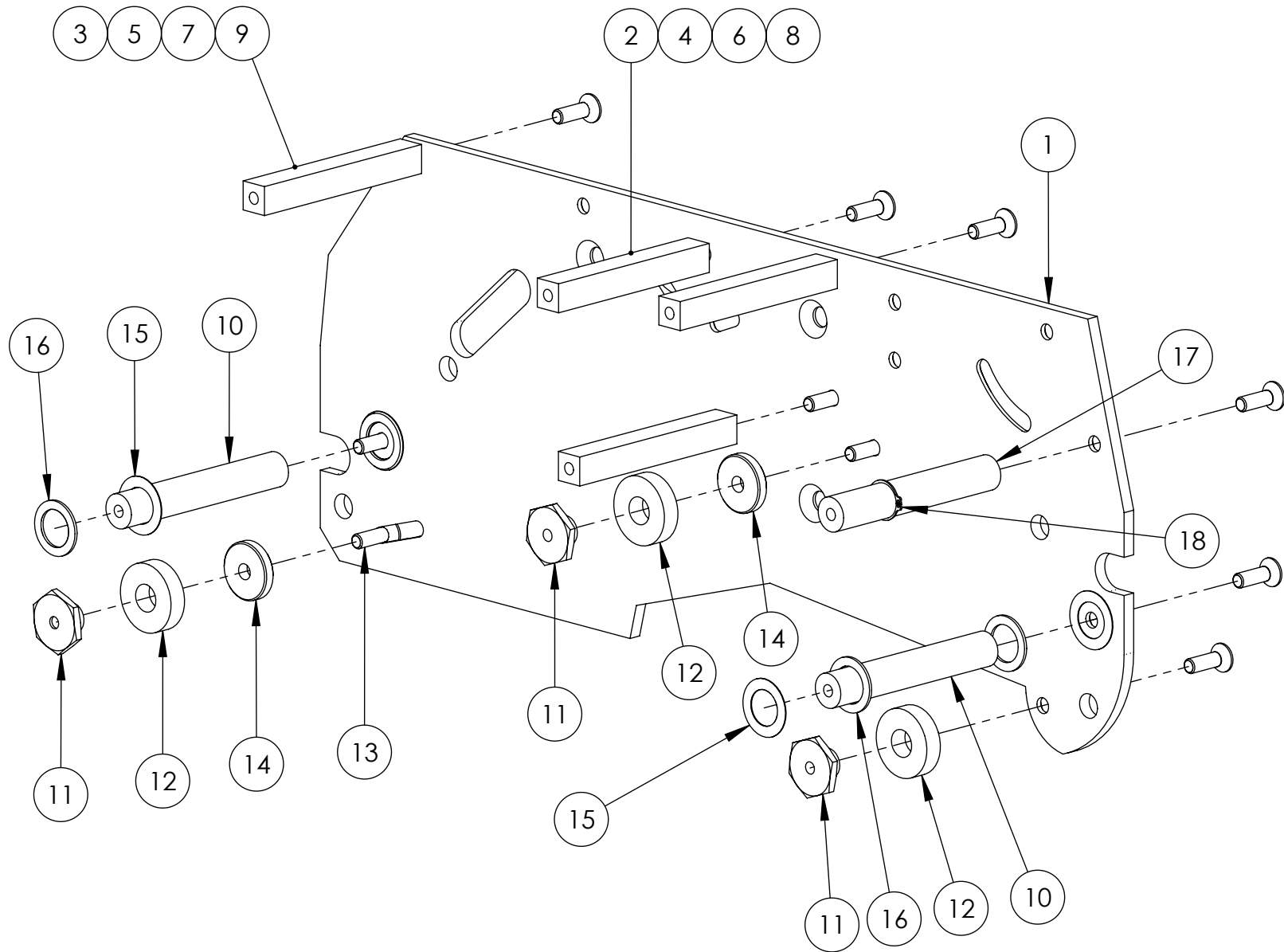

ITEM	PART #	DESCRIPTION	USH1033 2"/QTY.	USH1060 2"SS/QTY.	USH1034 3"/QTY.	USH1061 3"SS/QTY.
1	UPH3754	MAIN FRAME ET II	1	-	1	-
1	UPH3838	MAIN FRAME ET II SS	-	1	-	1
2	UPH9041	SPACER BAR ETM II	1	-	-	-
3	UPH3638	SPACER BAR ETM II	3	-	-	-
4	UPH7259	SPACER BAR ETM II	-	-	1	-
5	UPH3665	SPACER BAR ETM II	-	-	3	-
6	UPH9042	SPACER BAR ETM II	-	1	-	-
7	UPH3835	SPACER BAR ETM II	-	3	-	-
8	UPH7258	SPACER BAR ETM II	-	-	-	1
9	UPH3836	SPACER BAR ETM II	-	-	-	3
10	UPH3636	ARMS PIVOT SHAFT ETM II	2	2	-	-
10	UPH3664	ARMS PIVOT SHAFT ETM II	-	-	2	2
11	UPH0872	STOP RETAINER ETM	3	-	3	-
11	UPH1017	SS STOP RETAINER	-	3	-	3
12	UPH133	STOP, URETHANE KNIFE ARM	3	3	3	3
13	UF5404	FHCS M5 - 0.8 x 16 mm	10	-	10	-
13	UF3277	SS FHCS M5 - 0.8 x 16 mm	-	10	-	10
14	UF5800	FLAT WASHER DIA 5.5 x 20 - 4 THK	2	-	2	-
14	UPH3856	SS FLAT WASHER	-	2	-	2
15	UF6337	F.W. PTFE , 12.5 x 20 x 0.29 mm	4	4	4	4
16	UF6336	F.W. PTFE , 13 x 19 x 1 mm	4	4	4	4
17	UPH4667	SPRING BARREL SHAFT	1	1	-	-
17	UPH4668	SPRING BARREL SHAFT	-	-	1	1
18	UF6300	RETAINING RING FOR 12mm SHAFT	1	-	1	-
18	UF3558	SS RETAINING RING 12 mm SHAFT	-	1	-	1

FRONT COVER FRAME

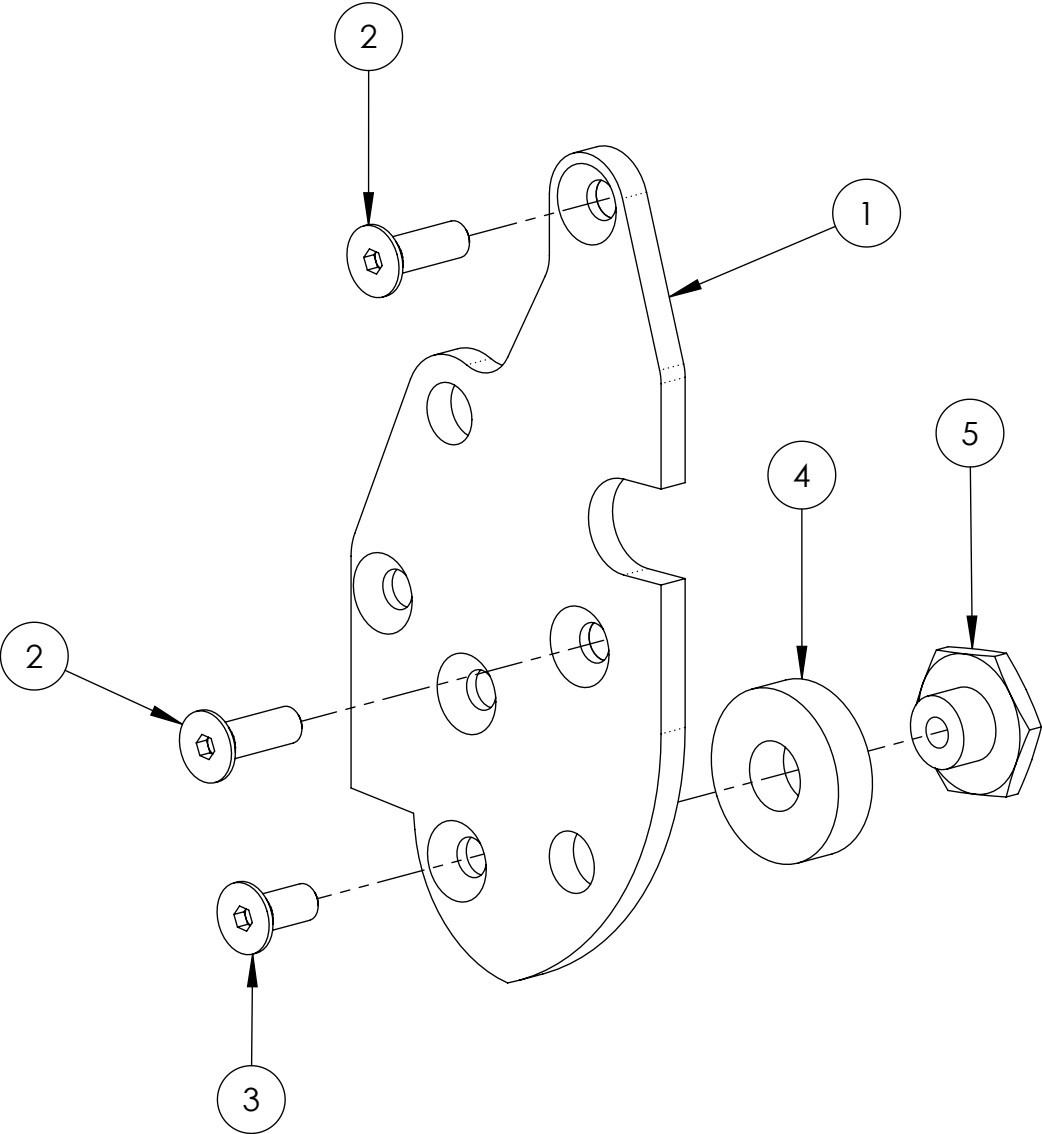

ITEM	PART #	DESCRIPTION	USH1035 QTY.	USH1036 SS QTY.
1	UPH9107	FRONT COVER FRAME	1	-
1	UPH9109	FRONT COVER FRAME	-	1
2	UF5404	FHCS M5 - 0.8 x 16 mm	2	-
2	UF3277	SS FHCS M5 - 0.8 x 16 mm	-	2
3	UF5400	FHCS M5-0.8 x 12 mm	1	-
3	UF3282	SS FHCS M5-0.8 x 12 mm	-	1
4	UPH133	STOP, URETHANE KNIFE ARM	1	1
5	UPH0872	STOP RETAINER ETM	1	-
5	UPH1017	SS STOP RETAINER	-	1

REAR COVER FRAME

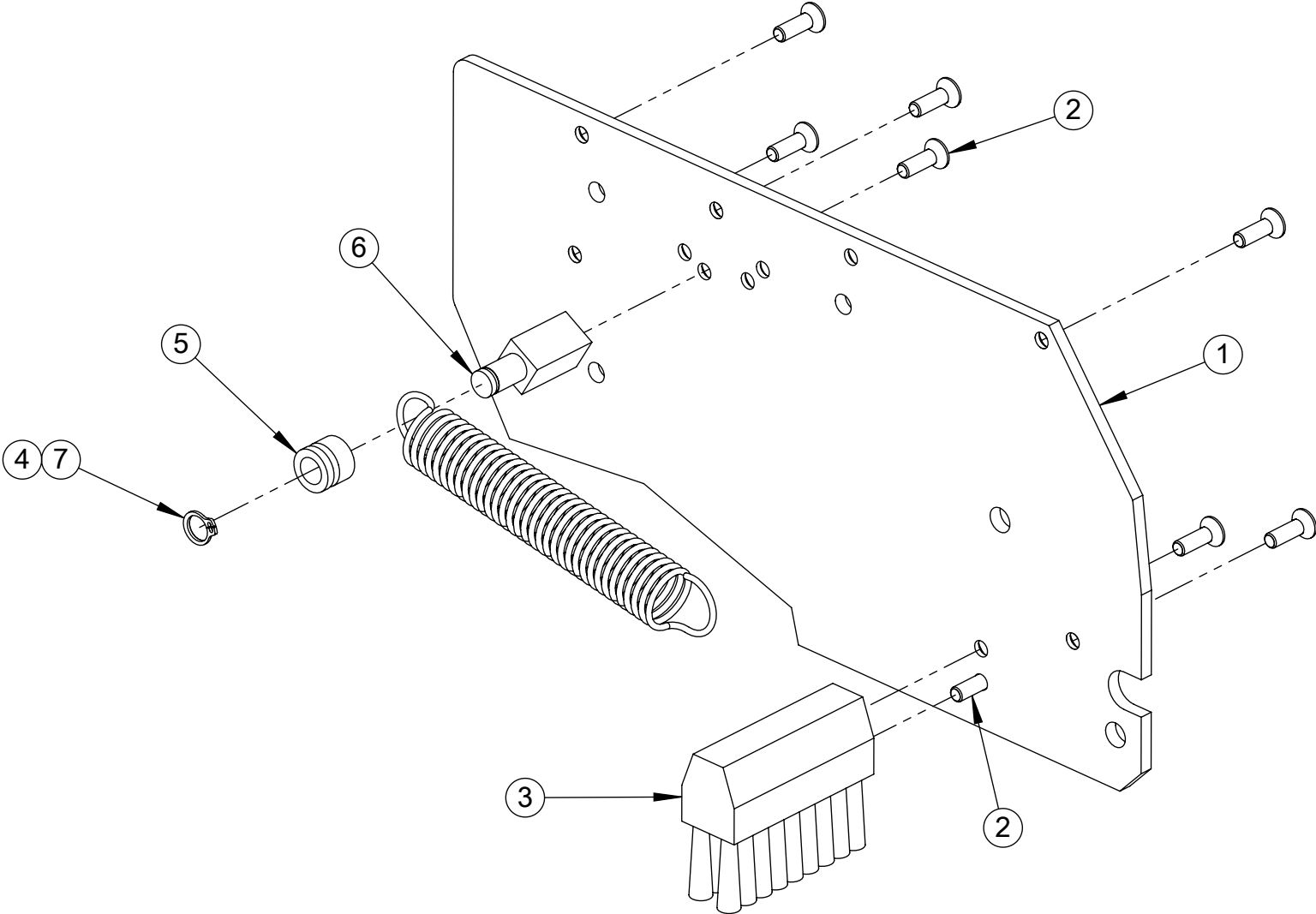

ITEM	PART #	DESCRIPTION	USH7019 - 2" QTY.	USH7020 - 3" QTY.	USH7021 - 2" SS QTY.	USH7022 - 3" SS QTY.
1	UPH9103	REAR COVER FRAME	1	1	-	-
1	UPH9105	REAR COVER FRAME SS	-	-	1	1
2	UF5404	FHCS M5 - 0.8 x 16 mm	8	8	-	-
2	UF3277	SS FHCS M5 - 0.8 x 16 mm	-	-	8	8
3	UPH3655	BRUSH 2"	1	-	1	-
3	UPH3674	BRUSH 3"	-	1	-	1
4	UF6303	EXT. RETAINING RING 9mm	1	1	-	-
5	UPH0863	MAIN SPRING RETAINER SLEEVE	1	1	1	1
6	UPH3640	RETAINER, MAIN SPRING 2"	1	-	-	-
6	UPH3666	RETAINER, MAIN SPRING 3"	-	1	-	-
6	UPH3833	RETAINER, MAIN SPRING 2" SS	-	-	1	-
6	UPH3834	RETAINER, MAIN SPRING 3" SS	-	-	-	1
7	UF3556	RETAINING RING 9 mm SS	-	-	1	1

NOTE: THE SPRING SHOWN IS FOR PRESENTATION PURPOSES ONLY, SEE PAGE 2.

REAR ARM

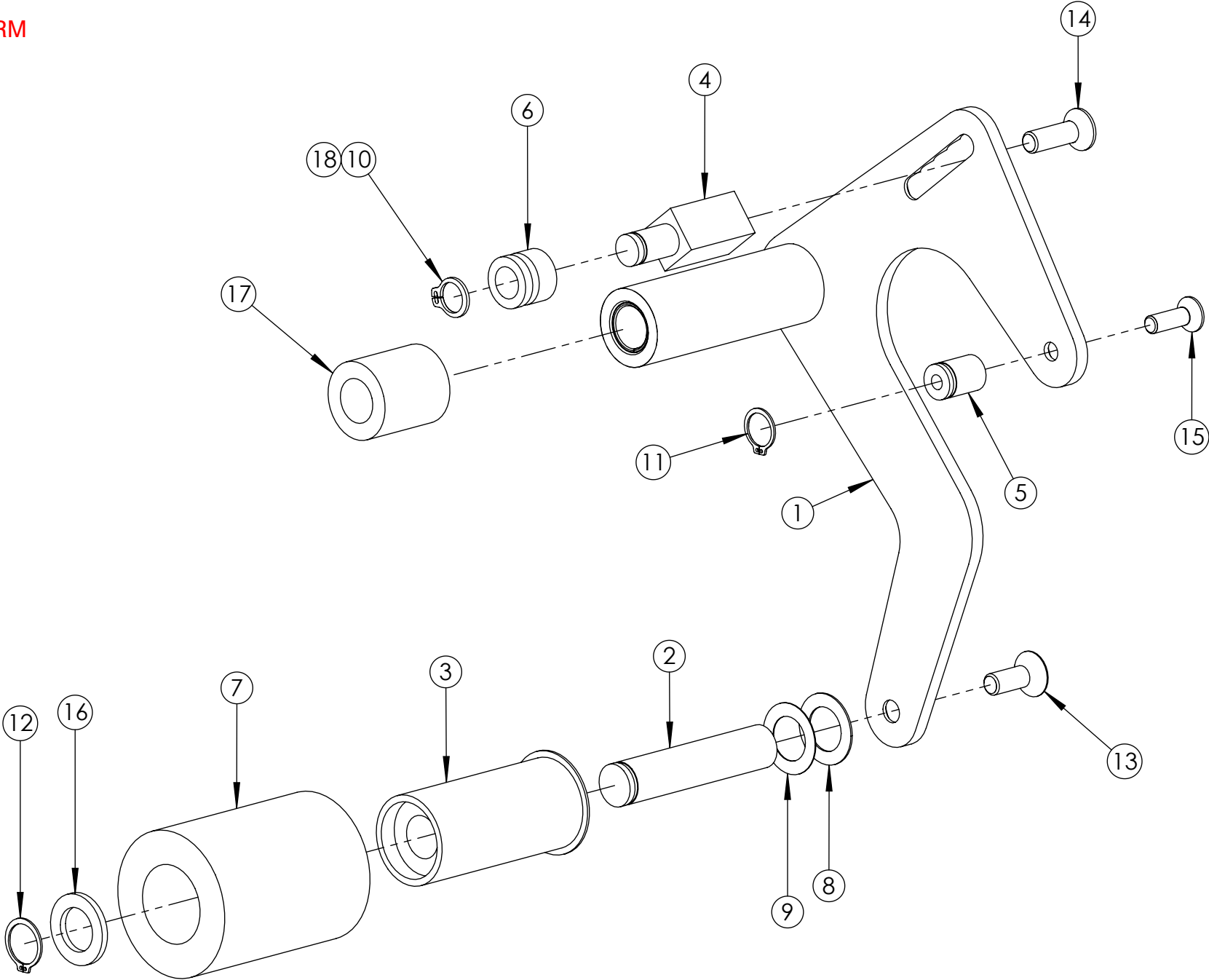

ITEM	PART #	DESCRIPTION	USH0774 2" QTY.	USH0786 3" QTY.	USH0872 2" SS QTY.	USH0881 3" SS QTY.
1	UAH0017	REAR ARM WITH BEARING	1	1	-	-
1	UAH0019	SS REAR ARM W. BEARING	-	-	1	1
2	UPH3643	SHAFT, ROLLER ETM II	1	-	1	-
2	UPH3668	SHAFT, ROLLER ETM II	-	1	-	1
3	UPH3641	ROLLER CORE	1	-	1	-
3	UPH3667	ROLLER CORE	-	1	-	1
4	UPH9199	RETAINER, MAIN SPRING	1	-	-	-
4	UPH9196	RETAINER, MAIN SPRING	-	1	-	-
4	UPH9197	RETAINER, MAIN SPRING	-	-	1	-
4	UPH9198	RETAINER, MAIN SPRING	-	-	-	1
5	UPH0886	LINK SHAFT ETM	1	1	1	1
6	UPH0863	MAIN SPRING RETAINER SLEEVE	1	1	1	1
7	UPH0775	ROLLER SHELL	1	-	1	-
7	UPH0966	ROLLER SHELL	-	1	-	1
8	UF6335	F.W. PTFE , 12.5 x 20 x 0.55 mm	1	1	1	1
9	UF6337	F.W. PTFE , 12.5 x 20 x 0.29 mm	1	1	1	1
10	UF6303	EXT. RETAINING RING 9mm	1	1	-	-
11	UF6301	RETAINING RING FOR 10 mm SHAFT	1	1	-	-
11	UF3557	SS RETAINING RING FOR 10 mm SHAFT	-	-	1	1
12	UF6300	RETAINING RING FOR 12mm SHAFT	1	1	-	-
12	UF3558	SS RETAINING RING 12 mm SHAFT	-	-	1	1
19	UF1192	FHCS M6-1 x 16 mm	1	1	1	1
14	UF5402	FHCS M6 - 1 x 20	1	1	-	-
14	UF3273	SS FHCS M6 x 20	-	-	1	1
15	UF5404	FHCS M5 - 0.8 x 16 mm	1	1	-	-
15	UF3277	SS FHCS M5 - 0.8 x 16 mm	-	-	1	1
16	UF1862	THRUST WASHER 12.4 x 20 x 2	1	1	-	-
16	UF1864	SS THRUST WASHER 12.4 x 20 x 2	-	-	1	1
17	UPH1031	SPACER	-	1	-	1
18	UF3556	RETAINING RING 9 mm SS	-	-	1	1

NOTE: ITEMS 8,9 TO FIT ASSEMBLY.

CLUTCH ASSEMBLY

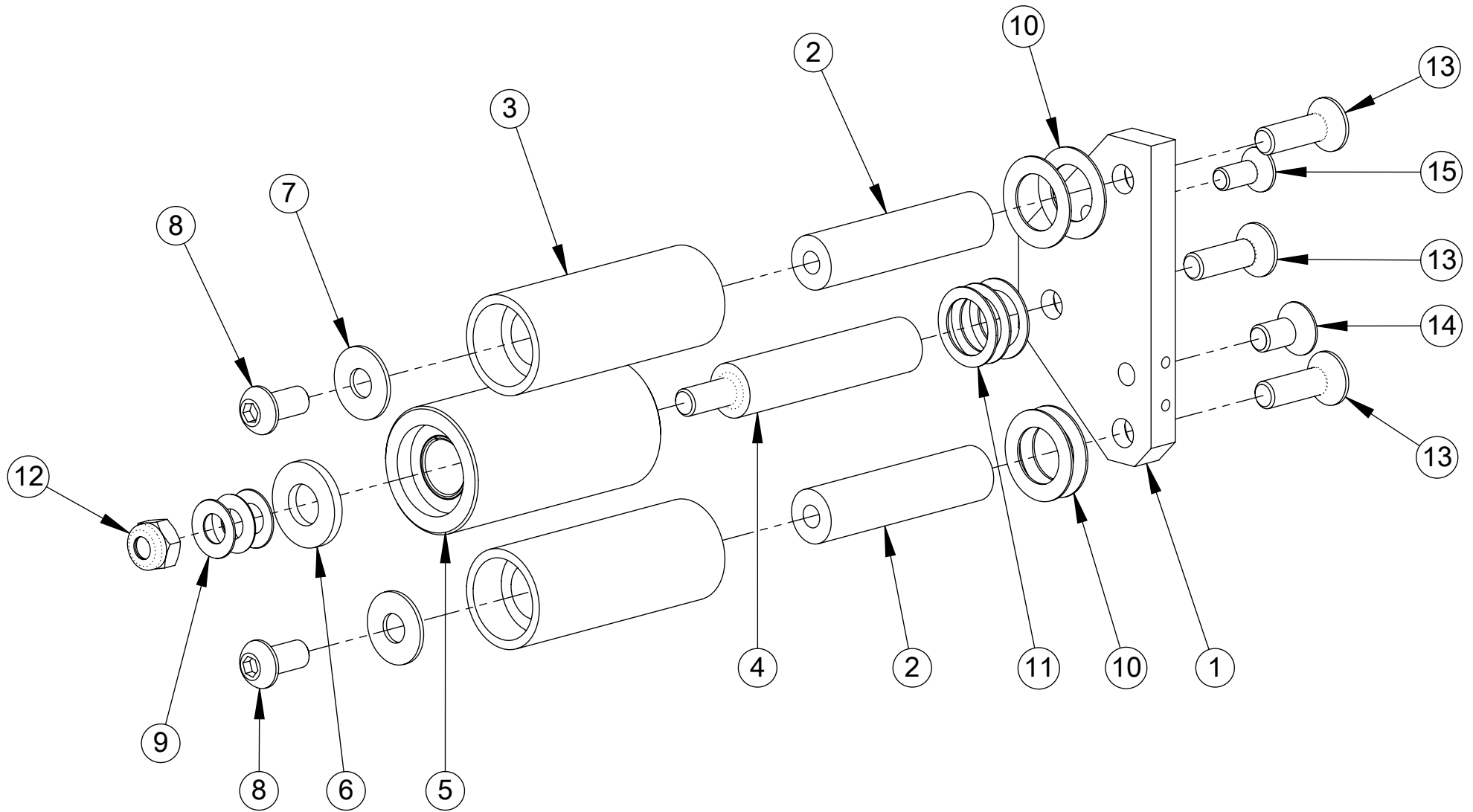

ITEM	PART #	DESCRIPTION	USH0775 2" QTY.	USH0787 3" QTY.	USH0870 2" SS QTY.	USH0879 3" SS QTY.
1	UPH3651	CLUTCH BRACKET ET II	1	1	1	1
2	UPH0887	GUIDE ROLLER SHAFT	2	-	2	-
2	UPH0949	GUIDE ROLLER SHAFT	-	2	-	2
3	UPH0888	GUIDE ROLLER ETM	2	-	2	-
3	UPH0950	GUIDE ROLLER ETM	-	2	-	2
4	UPH1028	CLUTCH SHAFT	1	-	1	-
4	UPH1254	CLUTCH SHAFT	-	1	-	1
5	UAH0029	CLUTCH W. BEARINGS 48	1	-	1	-
5	UAH0030	CLUTCH w. BEARINGS 72	-	1	-	1
6	UF6346	FW M8 NARROW	1	1	-	-
6	UF6347	SS FW M8 NARROW	-	-	1	1
7	UF6391	F.W. 6 x 16 x 1 mm	2	2	-	-
7	UF6390	SS F.W. 6 x 16 x 1	-	-	2	2
8	UF1195	BHCS M6-1 x 12 mm	2	2	-	-
8	UF3278	SS BHCS M6-1 x 12 mm	-	-	2	2
9	UF1870	BELLEVILLE W. 0.26 x 0.5 x .036	3	3	-	-
9	UF3461	SS BELLEVILLE W. 0.26 x 0.5 x .036	-	-	3	3
10	UF6335	F.W. PTFE , 12.5 x 20 x 0.55 mm	4	4	4	4
11	UF6402	F.W. PTFE , 12.5 x 17.5 x 0.5 mm	3	3	3	3
12	UF5900	NYLON LOCK NUT M6-1.0	1	1	-	-
12	UF3391	SS NYLON LOCK NUT M6-1.0	-	-	1	1
13	UF5402	FHCS M6 - 1 x 20	3	3	-	-
13	UF3273	SS FHCS M6 x 20	-	-	3	3
14	UF1042	FHCS M6-1 x 12 mm	1	1	-	-
14	UF6353	SS FHCS M6-1 x 12 mm	-	-	1	1
15	UF5400	FHCS M5-0.8 x 12 mm	1	1	-	-
15	UF3282	SS FHCS M5-0.8 x 12 mm	-	-	1	1

MANDREL ASSEMBLY

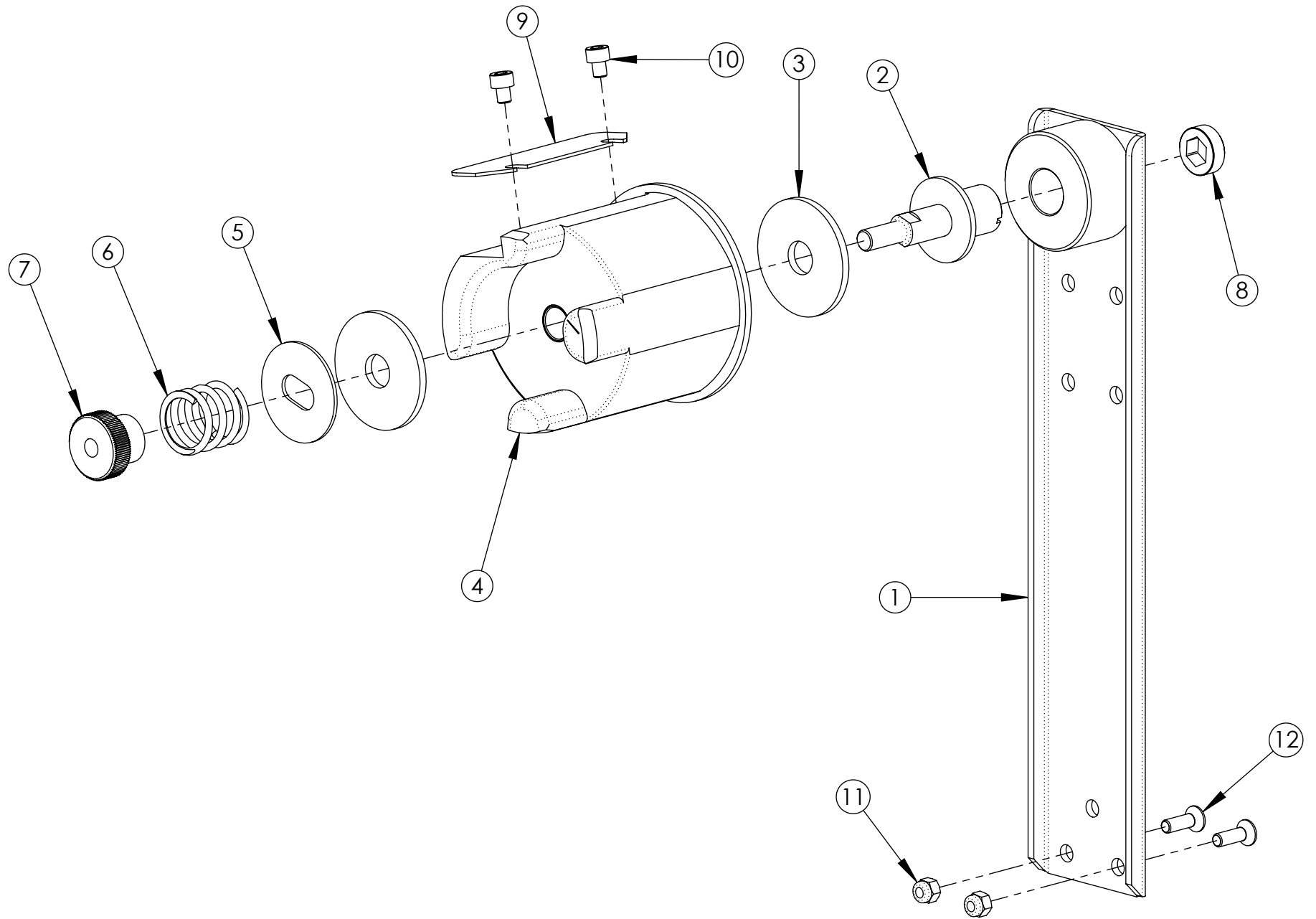

ITEM	PART #	DESCRIPTION	USH1008 - 2" QTY.	USH1009 - 3" QTY.	USH1010 - 2" SS QTY.	USH1011 - 3" SS QTY.
1	UAH0093	MANDREL ARM SUB ASS'Y	1	1	-	-
1	UAH0092	SS MANDREL ARM SUB ASS'Y	-	-	1	1
2	UPH3762	SHAFT, MANDREL ETII TW 2"	1	-	-	-
2	UPH3768	SHAFT, MANDREL ETII TW 3"	-	1	-	-
2	UPH9154	SHAFT, MANDREL ETII SS TW 2"	-	-	1	-
2	UPH9155	SHAFT, MANDREL ETII SS TW 3'	-	-	-	1
3	UF1920	FIBRE WASHER 1/2 x 1-3/4 x 1/8	2	2	2	2
4	UAH0072	MANDREL ET TW 48 w BEARINGS	1	-	1	-
4	UAH0073	MANDREL ET TW 72 w BEARINGS	-	1	-	1
5	UPH0897	MANDREL FRICTION WASHER	1	1	-	-
5	UPH1006	SS MANDREL FRICTION WASHER	-	-	1	1
6	UPH0210	MANDREL SPRING	1	1	-	-
6	UPH1037	SS MANDREL SPRING	-	-	1	1
7	UPH0895	MANDREL ADJUSTMENT NUT	1	1	-	-
7	UPH9055	SS MANDREL ADJUSTMENT NUT	-	-	1	1
8	UPH3764	MANDREL LOCKNUT	1	1	-	-
8	UPH7004	SS MANDREL LOCKNUT	-	-	1	1
9	UPH0898	CORE LOCK, MANDREL ET 48	1	-	1	-
9	UPH0958	CORE LOCK, MANDREL ET 72	-	1	-	1
10	UF3149	SS SHCS M5 - 0.8 x 6 mm	2	2	2	2
11	UF3393	NYLON LOCK NUT M5	2	2	-	-
11	UF3394	SS NYLON LOCK NUT M5	-	-	2	2
12	UF5404	FHCS M5 - 0.8 x 16 mm	2	2	-	-
12	UF3277	SS FHCS M5 - 0.8 x 16 mm	-	-	2	2

PEEL OFF ARM ASSEMBLY

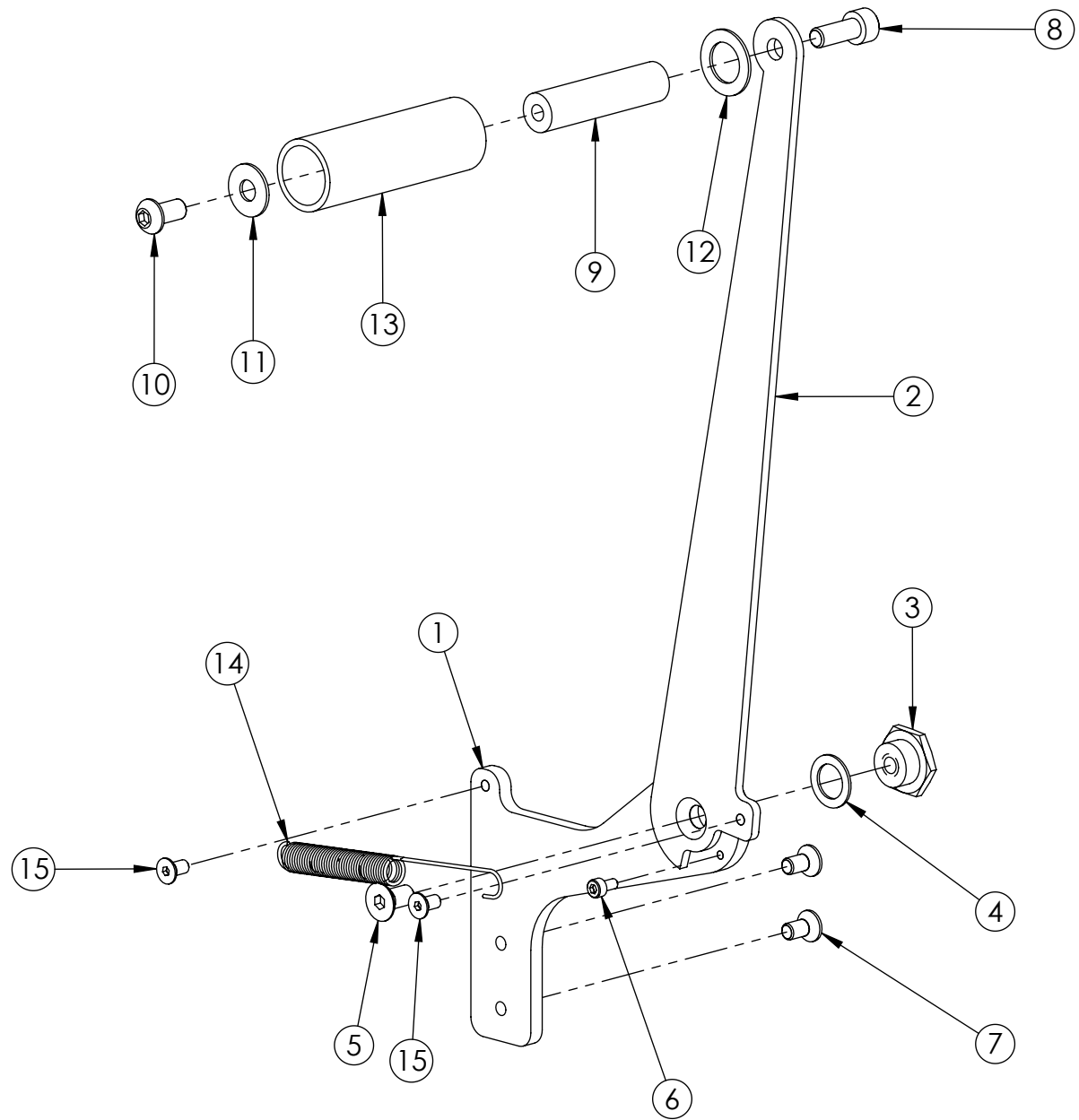

ITEM	PART #	DESCRIPTION	USH0768 - 2" QTY.	USH0883 - 2" SS QTY.	USH0884 - 3" SS QTY.	USH0886 - 3" QTY.
1	UPH1291	PEEL-OFF ARM SUPPORT ET	1	-	-	1
1	UPH3830	SS PEEL-OFF ARM SUPPORT ET	-	1	1	-
2	UPH1290	PEEL OFF ARM ETM	1	-	-	1
2	UPH3829	PEEL OFF ARM ETM	-	1	1	-
3	UPH0904	PEEL-OFF ARM PIVOT	1	-	-	1
3	UPH3827	PEEL-OFF ARM PIVOT	-	1	1	-
4	UF6388	NYLON F.W. 10.5 x 16 x 0.85 mm	1	1	1	1
5	UF1042	FHCS M6-1 x 12 mm	1	-	-	1
5	UF6353	SS FHCS M6-1 x 12 mm	-	1	1	-
6	UF5202	SHCS M3-0.5 x 6 mm	1	-	-	1
6	UF3145	SS SHCS M3-0.5 x 6 mm	-	1	1	-
7	UF6305	FHCS M5-0.8 x 10 mm	2	-	-	2
7	UF3262	SS FHCS M5-0.8 x 10 mm	-	2	2	-
8	UF0830	SHCS M6-1 x 16 mm	1	-	-	1
8	UF3187	SS SHCS M6-1 x 16 mm	-	1	1	-
9	UPH0887	GUIDE ROLLER SHAFT	1	1	-	-
9	UPH0949	GUIDE ROLLER SHAFT	-	-	1	1
10	UF1195	BHCS M6-1 x 12 mm	1	-	-	1
10	UF3278	SS BHCS M6-1 x 12 mm	-	1	1	-
11	UF6391	F.W. 6 x 16 x 1 mm	1	-	-	1
11	UF6390	SS F.W. 6 x 16 x 1	-	1	1	-
12	UF1861	THRUST WASHER 12.4 x 20 x 1	1	-	-	1
12	UF1863	SS THRUST WASHER 12.4 x 20 x 1	-	1	1	-
13	UPI0061	PEEL OFF ROLLER ET 48	1	1	-	-
13	UPI0070	PEEL OFF ROLLER ET 72	-	-	1	1
14	UPH1289	SPRING PEEL OFF ETM	1	-	-	1
14	UPH3828	SPRING PEEL OFF ETM	-	1	1	-
15	UF5401	FHCS M4-0.7 x 8 mm	2	-	-	2
15	UF3274	SS FHCS M4-0.7 x 8 mm	-	2	2	-

LINK ASSEMBLY

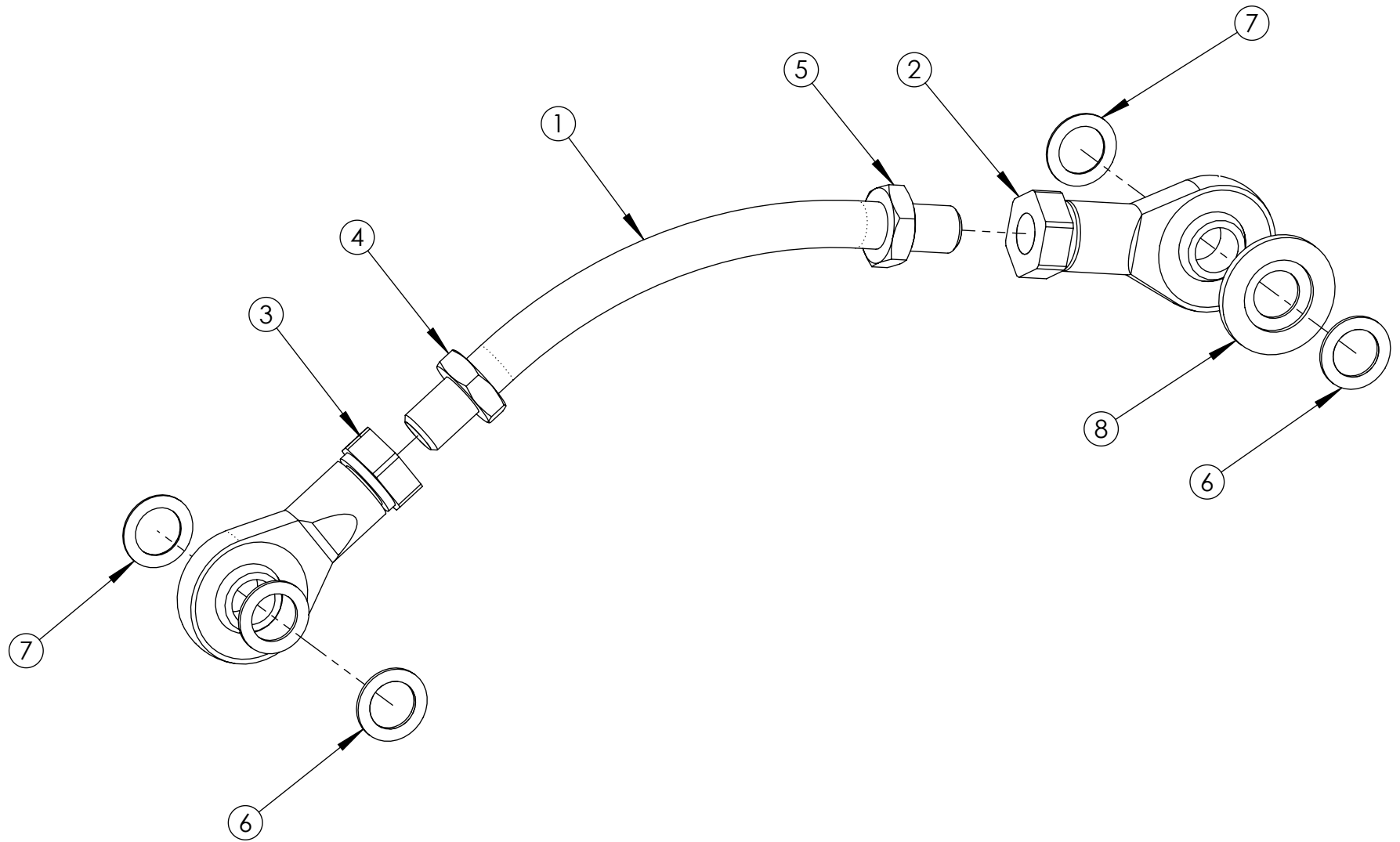

ITEM	PART #	DESCRIPTION	USH0939 QTY.
1	UPH7100	LINK ROD	1
2	UPH7101	ROD END BEARING, 10 mm R.H.	1
3	UPH7102	ROD END BEARING, 10 mm L.H.	1
4	UF1661	HEX JAM NUT M10-1.5 LEFT	1
5	UF3708	HEX JAM NUT M10-1.5	1
6	UF6388	NYLON F.W. 10.5 x 16 x 0.85 mm	4
7	UF6389	NYLON F.W. 10.5 x 16 x 0.5 mm	2
8	UF3092	NYLON WASHER 26 x 16 x 2	1

FRONT ARM

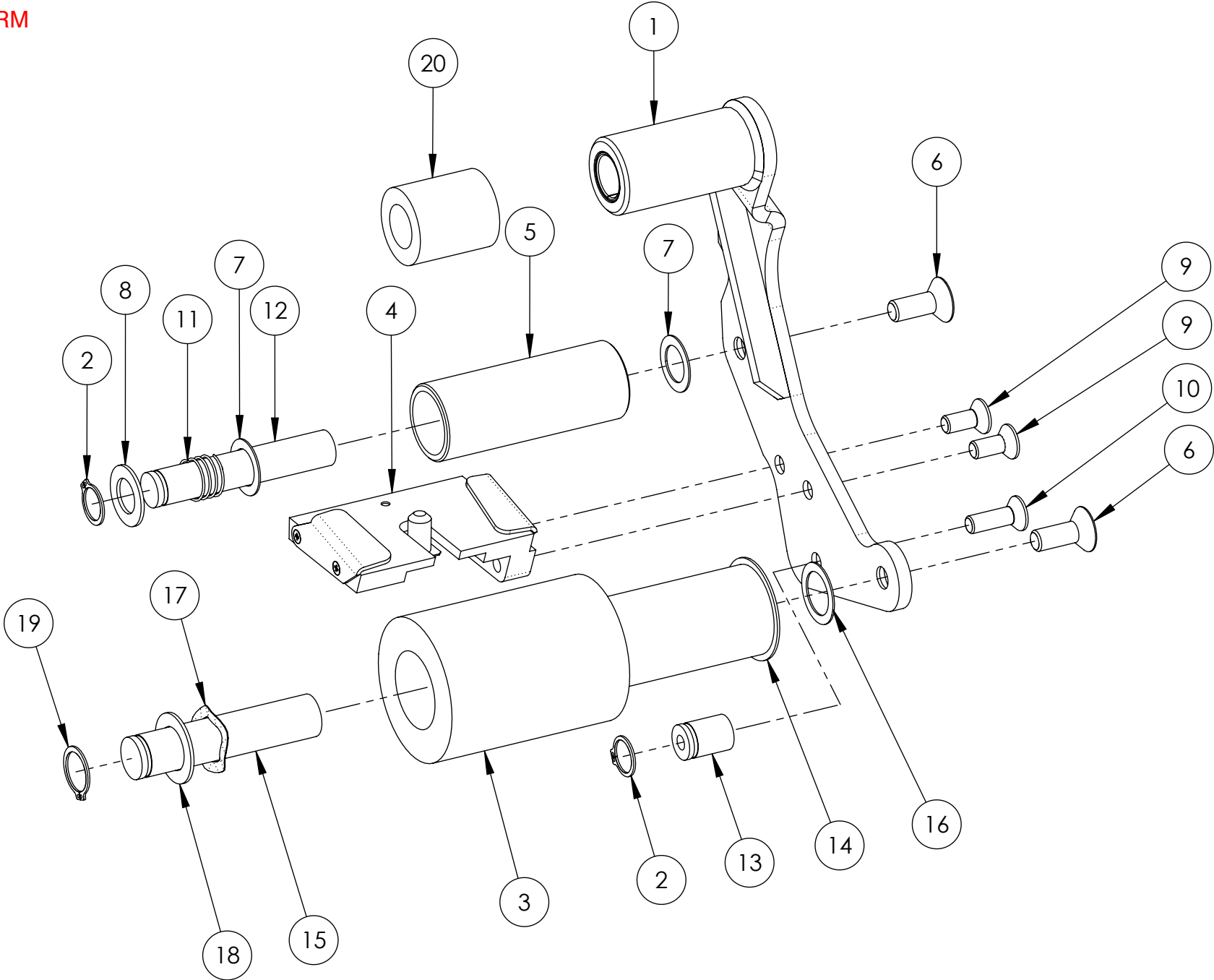

ITEM	PART #	DESCRIPTION	USH0521 2"/QTY.	USH1030 3"/QTY.	USH1031 2"SS/QTY.	USH1032 3"SS/QTY.
1	UAH0120	FRONT ARM WITH BEARING	1	1	-	-
1	UAH0140	FRONT ARM WITH BEARING SS	-	-	1	1
2	UF6301	RETAINING RING FOR 10 mm SHAFT	2	2	-	-
2	UF3557	SS RETAINING RING FOR 10 mm SHAFT	-	-	2	2
3	UPH0775	ROLLER SHELL	1	-	1	-
3	UPH0966	ROLLER SHELL	-	1	-	1
4	UAH0009	TAPE SHOE ASS'Y 48	1	-	-	-
4	UAH0010	TAPE SHOE ASS'Y 72	-	1	-	-
4	UAH0011	TAPE SHOE ASS'Y 48 SS	-	-	1	-
4	UAH0012	TAPE SHOE ASS'Y 72 SS	-	-	-	1
5	UAH0074	GUIDE ROLLER W. BEARINGS 48	1	-	-	-
5	UAH0075	GUIDE ROLLER W. BEARINGS 72	-	1	-	-
5	UAH0141	GUIDE ROLLER W. BEARINGS 48 SS	-	-	1	-
5	UAH0142	GUIDE ROLLER W. BEARINGS 72 SS	-	-	-	1
6	UF1192	FHCS M6-1 x 16 mm	2	2	-	-
6	UF3261	SS FHCS M6 -1 x 16 mm	-	-	2	2
7	UF6389	NYLON F.W. 10.5 x 16 x 0.5 mm	2	2	2	2
8	UF1798	THRUST WASHER 10.1 x 17.3 x 1	1	1	-	-
8	UF1797	SS THRUST WASHER 10.1 x 17.3 x 1	-	-	1	1
9	UF5400	FHCS M5-0.8 x 12 mm	2	2	-	-
9	UF3282	SS FHCS M5-0.8 x 12 mm	-	-	2	2
10	UF5404	FHCS M5 - 0.8 x 16 mm	1	1	-	-
10	UF3277	SS FHCS M5 - 0.8 x 16 mm	-	-	1	1
11	UPH0281	SPRING - TAPE GUIDE ROLLER T.H.	1	1	1	1
12	UPH0884	PTFE ROLLER SHAFT 48	1	-	1	-
12	UPH0968	PTFE ROLLER SHAFT 72	-	1	-	1
13	UPH0886	LINK SHAFT ETM	1	1	1	1
14	UPH3641	ROLLER CORE	1	-	1	-
14	UPH3667	ROLLER CORE	-	1	-	1
15	UPH3643	SHAFT, ROLLER ETM II	1	-	1	-
15	UPH3668	SHAFT, ROLLER ETM II	-	1	-	1
16	UF6402	F.W. PTFE , 12.5 x 17.5 x 0.5 mm	1	1	1	1
17	UPH0703	WAVE DISC SPRING	1	1	1	1
18	UF1861	THRUST WASHER 12.4 x 20 x 1	1	1	-	-
18	UF1863	SS THRUST WASHER 12.4 x 20 x 1	-	-	1	1
19	UF6300	RETAINING RING FOR 12mm SHAFT	1	1	-	-
19	UF3558	SS RETAINING RING 12 mm SHAFT	-	-	1	1
20	UPH1031	SPACER	-	1	-	1

TAPE SHOE

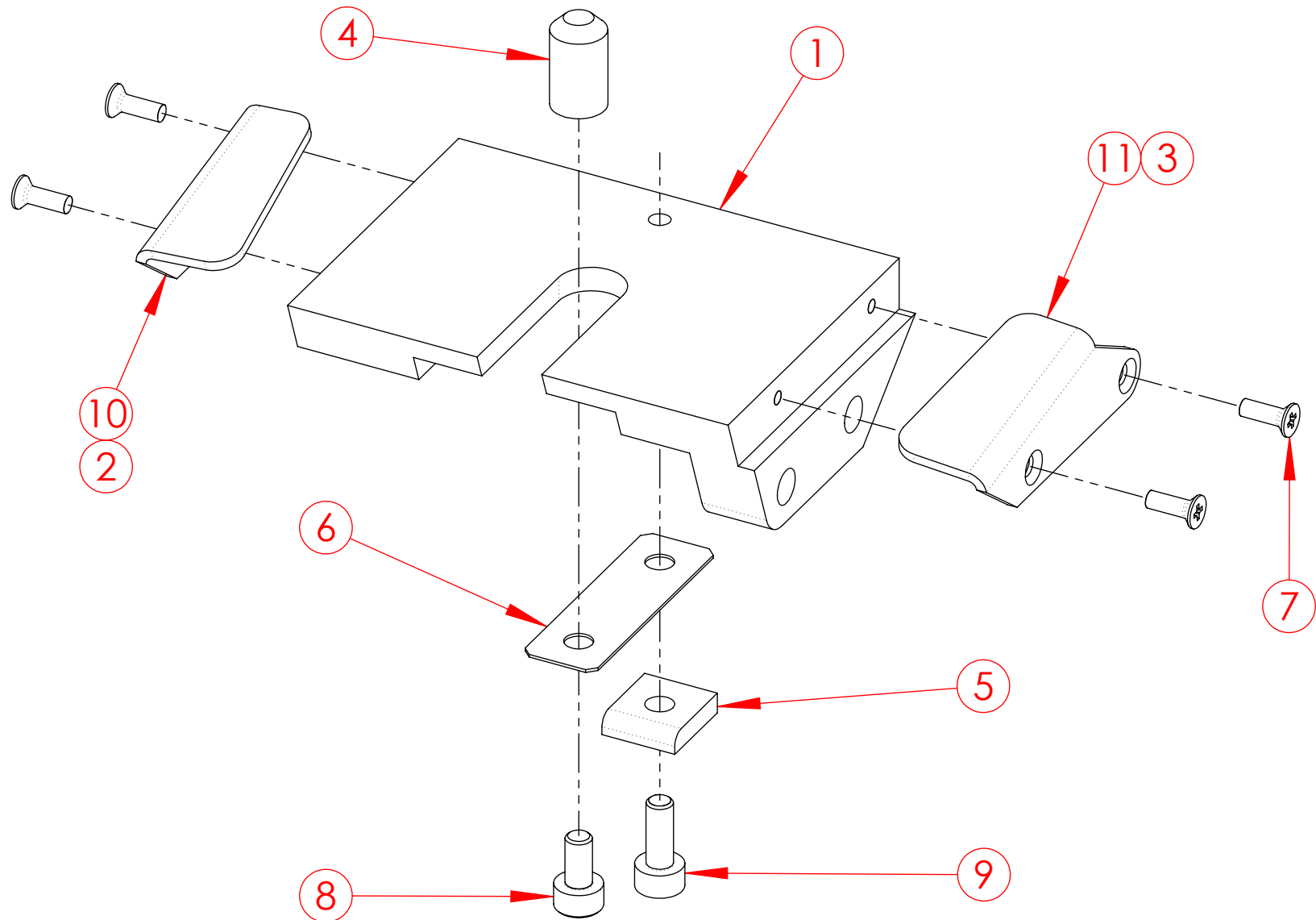

ITEM	PART #	DESCRIPTION	UAH0009 2" /QTY.	UAH0010 3" /QTY.	UAH0011 2"SS/QTY.	UAH0012 3"SS/QTY.
1	UPH3644	TAPE SHOE 48	1	-	1	-
1	UPH3663	TAPE SHOE 72	-	1	-	1
2	UPH0882	TAPE SHOE GUIDE L.H.	1	-	-	-
2	UPH1021	SS TAPE SHOE GUIDE L.H.	-	-	1	-
3	UPH0883	TAPE SHOE GUIDE R.H.	1	-	-	-
3	UPH1032	SS TAPE SHOE GUIDE R.H.	-	-	1	-
4	UPH0879	FINGER	1	1	1	1
5	UPH0880	SQARE WASHER	1	1	-	-
5	UPH1019	SS SQARE WASHER	-	-	1	1
6	UPH3706	SPRING BLADE	1	1	-	-
6	UPH3705	SS SPRING BLADE	-	-	1	1
7	UF5406	FHCS M2-0.4 x 6 mm	4	4	-	-
7	UF3259	SS FHCS M2-0.4 x 6 mm	-	-	4	4
8	UF5202	SHCS M3-0.5 x 6 mm	1	1	-	-
8	UF3145	SS SHCS M3-0.5 x 6 mm	-	-	1	1
9	UF6400	SHCS M3-0.5 x 8	1	1	-	-
9	UF6401	SS SHCS M3-0.5 x 8	-	-	1	1
10	UPH0836	TAPE SHOE GUIDE L.H.	-	1	-	1
11	UPH0323	TAPE SHOE GUIDE R.H.	-	1	-	1

KNIFE ARM

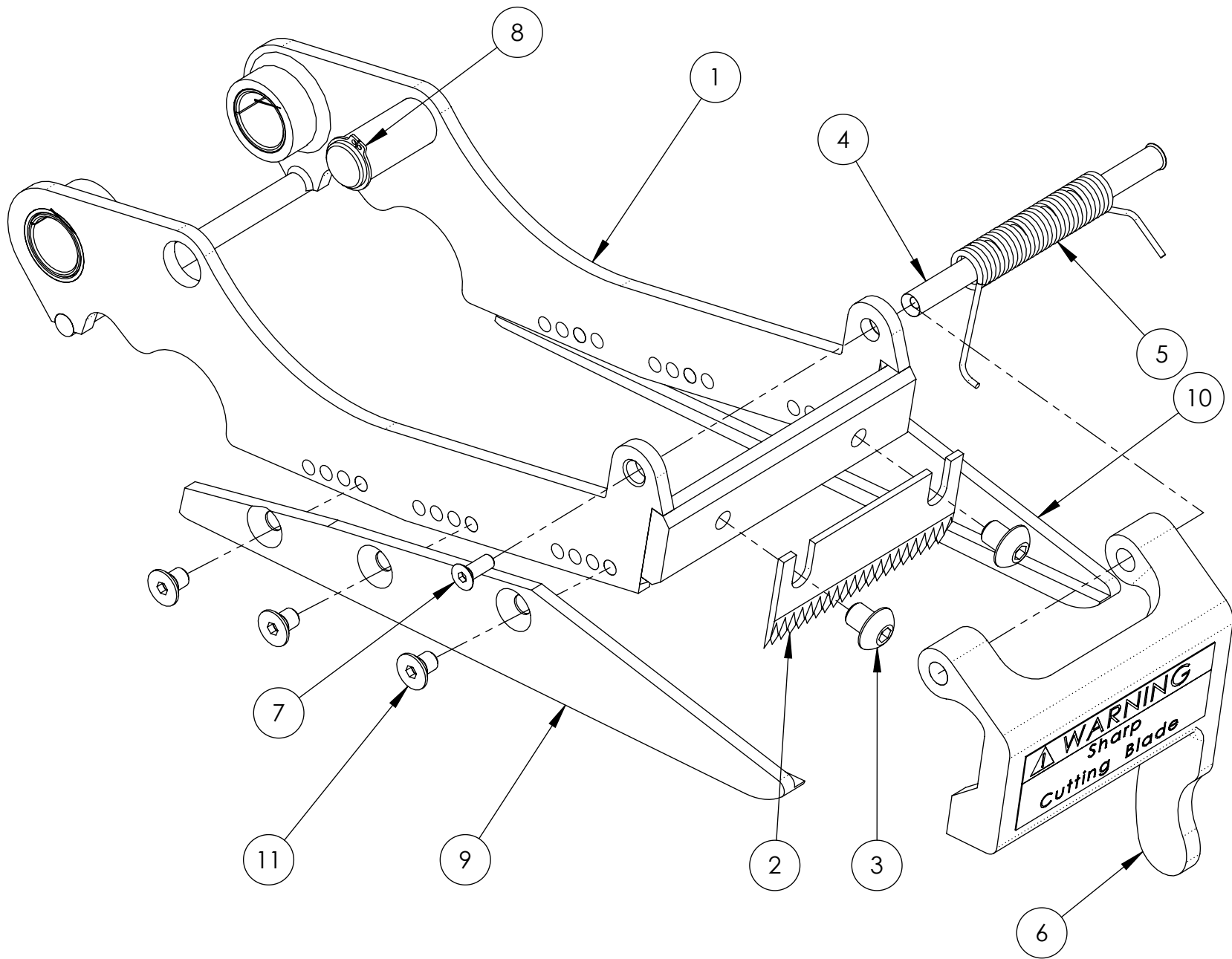

ITEM	PART #	DESCRIPTION	USH0522 2" QTY.	USH0524 3" QTY.	USH3851 2"SS QTY.	USH3852 3"SS QTY.
1	UAH0121	KNIFE ARM WITH BEARINGS 2"	1	-	-	-
1	UAH0137	KNIFE ARM WITH BEARINGS 3"	-	1	-	-
1	UAH0143	KNIFE ARM WITH BEARINGS 2" SS	-	-	1	-
1	UAH0144	KNIFE ARM WITH BEARINGS 3" SS	-	-	-	1
2	UPH0239	CUT-OFF BLADE 48	1	-	1	-
2	UPH0240	CUT-OFF BLADE 75	-	1	-	1
3	UF5601	BHCS M5 X 0.8 X 6mm	2	2	-	-
3	UF3276	SS BHCS M5 X 0.8 X 6mm	-	-	2	2
4	UPH 9175	SHAFT, BLADE GUARD	1	-	1	-
4	UPH 9178	SHAFT, BLADE GUARD	-	1	-	1
5	UPH9099	TORSION SPRING	1	1	-	-
5	UPH9195	SS TORSION SPRING	-	-	1	1
6	UAH0113	PLASTIC KNIFE GUARD 2"	1	-	1	-
6	UAH0114	PLASTIC KNIFE GUARD 3"	-	1	-	1
7	UF6312	FHCS M3-0.5 x 8 mm	2	2	-	-
7	UF6350	SS FHCS M3-0.5 x 8 mm	-	-	2	2
8	UF6301	RETAINING RING FOR 10 mm SHAFT	1	1	-	-
8	UF3557	SS RETAINING RING FOR 10 mm SHAFT	-	-	1	1
9	UPH8082	KNIFE ARM EXTENSION RIGHT	1	1	-	-
9	UPH7424	KNIFE ARM EXTENSION RIGHT SS	-	-	1	1
10	UPH8083	KNIFE ARM EXTENSION LEFT	1	1	-	-
10	UPH7425	KNIFE ARM EXTENSION LEFT SS	-	-	1	1
11	UF6352	FHCS M4-0.7 x 6 mm	6	6	-	-
11	UF6351	SS FHCS M4-0.7 x 6 mm	-	-	6	6

REPULSIVE PIVOT ASSEMBLY

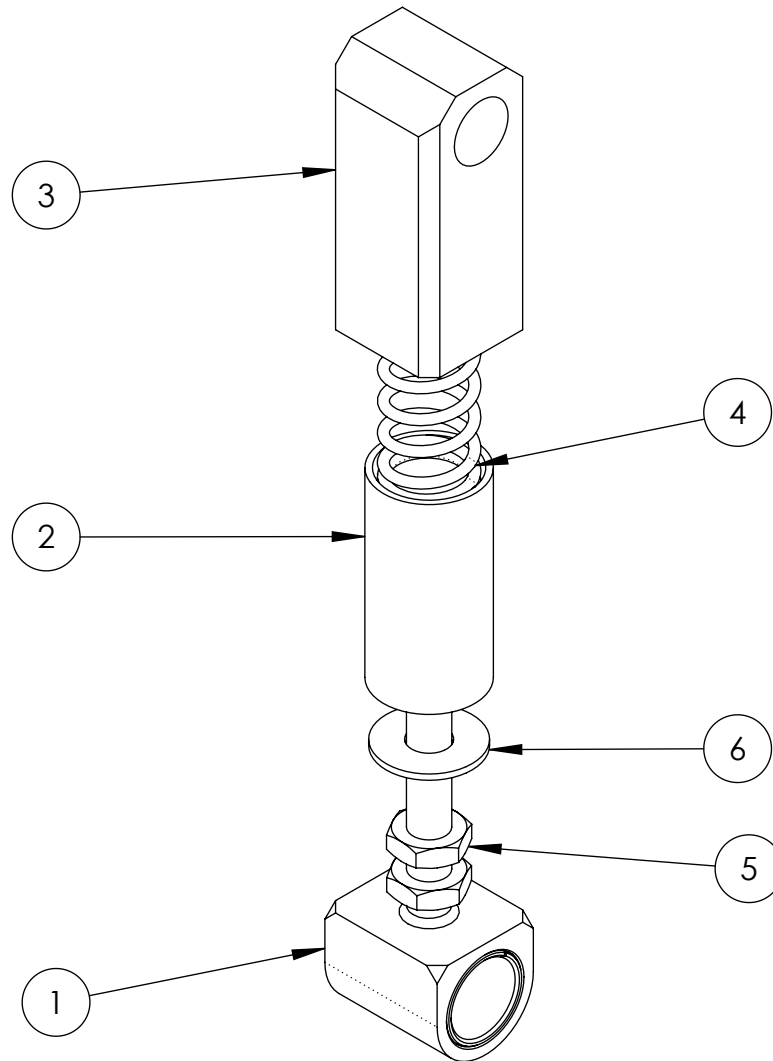

ITEM	PART #	DESCRIPTION	USH1057 /QTY.	USH1058 /QTY.
1	UAH0150	SPRING MANDREL V2	1	-
1	UAH0151	SPRING MANDREL V2 SS	-	1
2	UPH7678	SPRING GUIDE V2	1	1
3	UPH8111	SPRING BARREL V2	1	1
4	UPH4665	COMP. SPRING 13.7 O.D. 1.7 W.D. 50.8 LONG	1	-
4	UPH7427	COMP. SPRING 13.7 O.D. 1.7 W.D. 50.8 L. SS	-	1
5	UF9149	JAM NUT M6	2	-
5	UF3361	SS JAM NUT M6	-	2
6	UF6391	F.W. 6 x 16 x 1 mm	1	-
6	UF6390	SS F.W. 6 x 16 x 1	-	1

No Tape Sensor (Option)

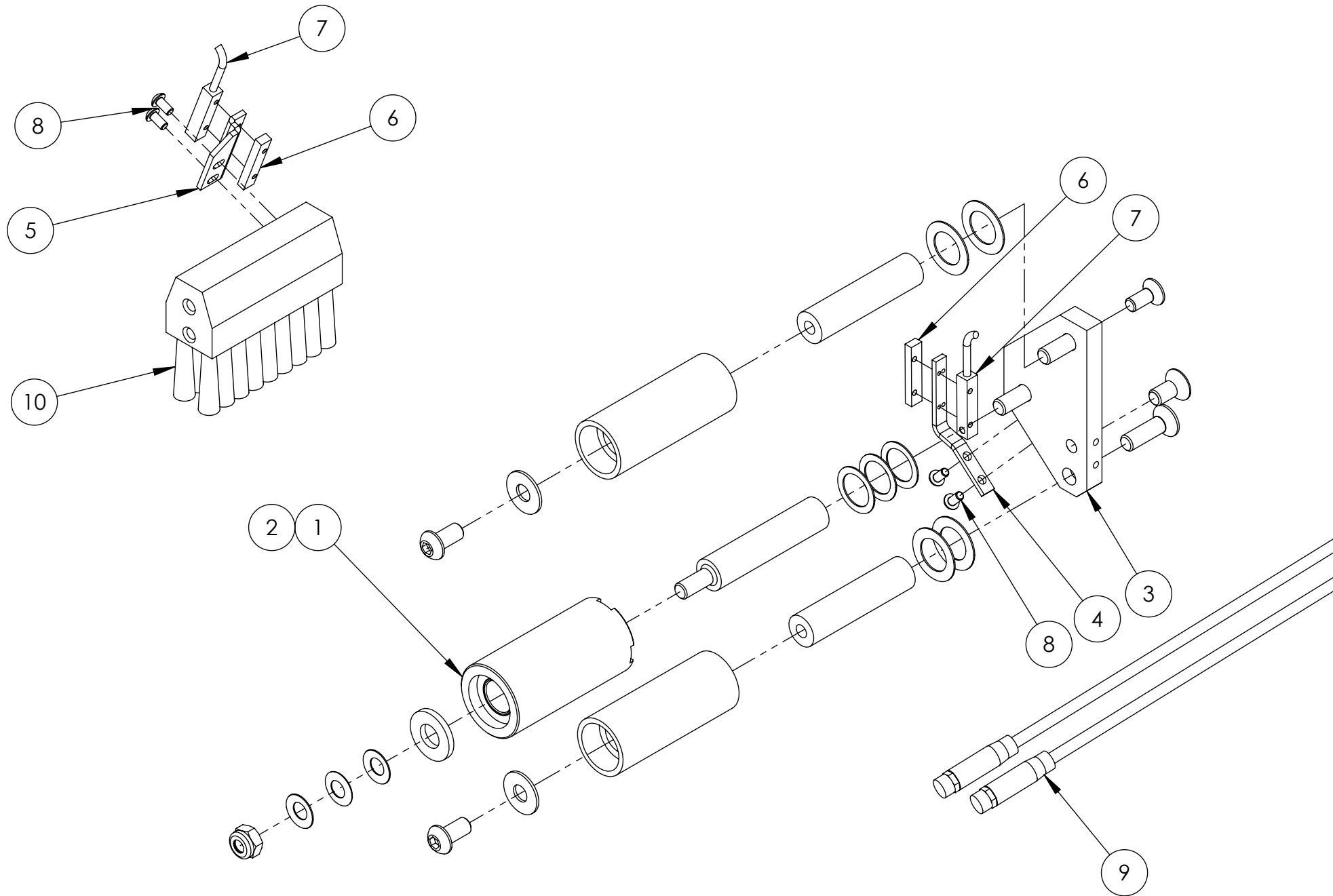

No Tape Sensor (Option)

Tape Heads with Serial Numbers Starting in H175 use USH1089

Tape Heads with Serial Numbers Starting in H675 use USH1088

ITEM	PART #	DESCRIPTION	USH1089 2"/QTY.	USH1088 3"/QTY.
1	UAH0160	CLUTCH W. BEARINGS LTNT 48	1	-
2	UAH0161	CLUTCH w. BEARINGS LTNT 72	-	1
3	UPI0152	CLUTCH BRACKET NT	1	1
4	UPH9072	SENSOR BRACKET	1	1
5	UPH2200	SENSOR BRACKET	1	1
6	UPH9073	SPACER PROX NO TAPE	2	2
7	UPM7329	PROX 5X5mm QD EXT DIST - NPN	2	2
8	UF6385	BHCS M3 - 0.5 x 6	4	4
9	UPM7330	M8 CABLE	2	2
10	UPY0008	BRUSH 2"	1	-
11	UPY0009	BRUSH 3"	-	1

Note: For Sensor Output Diagram refer to Page 72.

Low Tape Sensor (Option)

USH1087

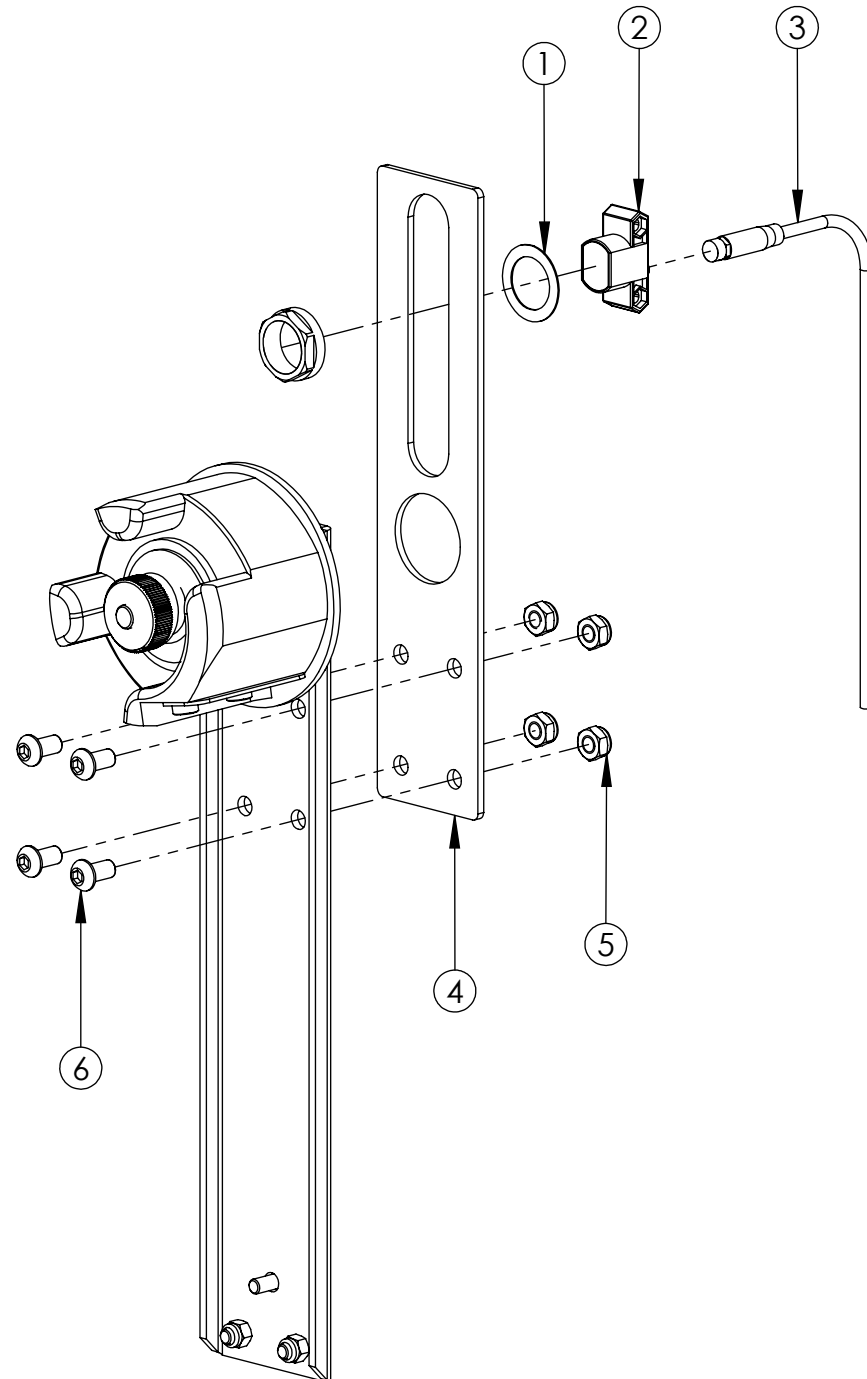

Low Tape Sensor (Option)

Tape Head with Serial Numbers Starting in H175 or H675 use USH1087.

ITEM	PART#	DESCRIPTION	QTY.
1	UF4255	FLAT WASHER	1
2	UPM4747	PHOTOELECTRIC SENSOR	1
3	UPM0320	M12 CABLE	1
4	UPM4040	LTNT PLATE	1
5	UF3391	SS NYLON LOCK NUT M6-1.0	4
6	UF3278	SS BHCS M6-1 x 12 mm	4

LTNT SENSOR DIAGRAM OUTPUT TYPE

TAPE HEADS SHIPS WITH NPN SENSORS

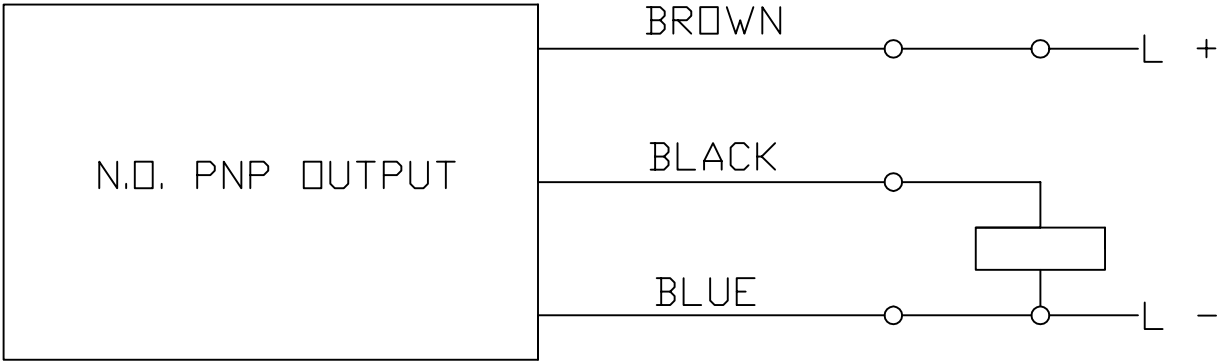
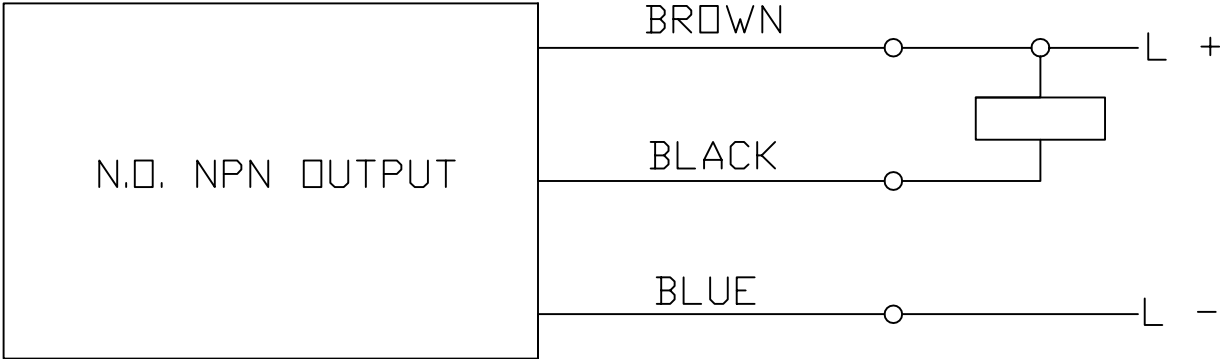

CONTACT FACTORY FOR PNP SENSORS

	
ELECTRICAL SCHEMATIC SENSOR OUTPUT DIAGRAM EL0001045	
FILE: EL0001045-02.dwg	
USED ON: LTNT TAPE HEAD SYSTEM	
ENG BY: BH	DATE: 08/13/2012
DWN BY: BH	REV: 1
SHEET 1 OF 1	SIZE
EL0001045-02.dwg	A