

Clarke[®]

FM40 ST, FM40 LX

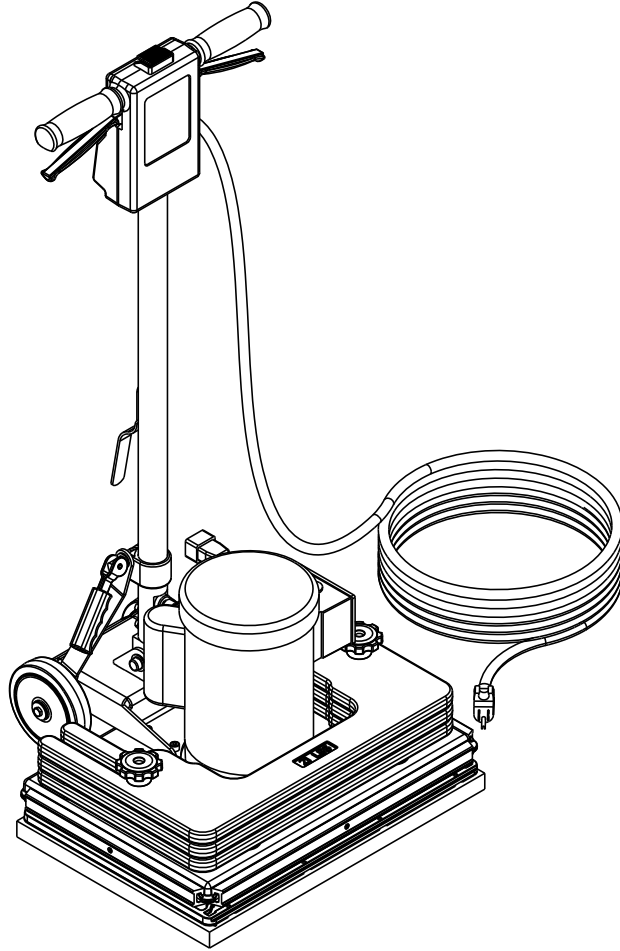

Parts List

Models: 56105618, 56105620

TABLE OF CONTENTS

DESCRIPTION	PAGE
General View and Options.....	1
Handle Assy.....	2-3
Wiring Diagram.....	3
Base Assy-LX.....	4-5
Base Assy-ST.....	6-7

WHEN ORDERING PARTS

* Use the part numbers from the "Ref. No." columns in this parts list. If the "Ref. No." column is blank; look under the "Kit" column to identify which kit contains the part in question, then use the kit callout, for example "K1", to find the "Ref. No." for that kit.

Kit	Item	Ref. No.	Qty	Description
K1	1		16	Washer Flat 3/16 Zinc Plat
K1	2		2	Screw-BHS-Brass-10-32x3/8-MS
K1	3		3	Washer EPDM 7/32 X 1/8
	4	805	1	Chain-Cover
	5	905	2	Caster Swivel 4 Gray Non MA
K1	6		2	Nut, Hex Nyl Loc 10-24
K1	7		3	Scr- Hex SS 1/4-20 X .75
K1	8		16	Scr, Hex Hd Loc 1/4-20 x .50
K1	9		3	Wsh, Flt SS .260 X 1.000 X .074
	10	56113012	1	Solution Tank
	11	56113034	2	Hinge Plate
K1		<u>56113103</u>	1	Kit-Hardware Solution Tank

* Specify the model and serial number of the machine.

* Use the space below to record the model and serial number for future reference.

Model _____ Serial No. _____

GENERAL VIEW AND OPTIONS

Item	Ref. No.	Qty	Description
1		1	Handle Assembly-14 X 20
2	56105733	1	Decal-FM40 ST
2	56105734	1	Decal-FM40 LX
3		1	Base Assembly
4	56105756	1	Decal-Wheel-Lock (FM40 LX only)
5	56105780	1	Base Board Kit (Std. on LX, optional on ST) TSB-FC-2015-045

OPTIONS

*	56105738	1	2.5 Gallon Tank Kit
*	56105780	1	Base Board Kit TSB-FC-2015-045
*	56105742	1	Vacuum Skirt Kit
*	56105772	1	Skirt-Splash Kit
*	56105746	1	Isolator-FM810-FM40 Kit
*	56105747	1	Bonnet-Carpet-14x20-2/Cs
*	56105748	1	Pad-Diamond-800gr-14x20-2/Cs
*	56105749	1	Pad-Diamond-1500gr-14x20-2/Cs
*	56105750	1	Pad-Diamond-3000gr-14x20-2/Cs
*	56105751	1	Pad-Diamond-8000gr-14x20-2/Cs
*	56105779	1	Pad-Grout-4x20-10/Cs
*	56383923	1	Pad-Grout-14x20-4/Cs
*	997022	1	Pad-Black-14x20-5/Cs
*	997021	1	Pad-Blue-14x20-5/Cs
*	997024	1	Pad-Maroon-14x20-10/Cs
*	997020	1	Pad-Red-14x20-5/Cs
*	56105778	1	Pad-Edge-Red-4x20-10/Cs
*	997023	1	Pad-White-14x20-5/Cs

* = Optional, Not Included

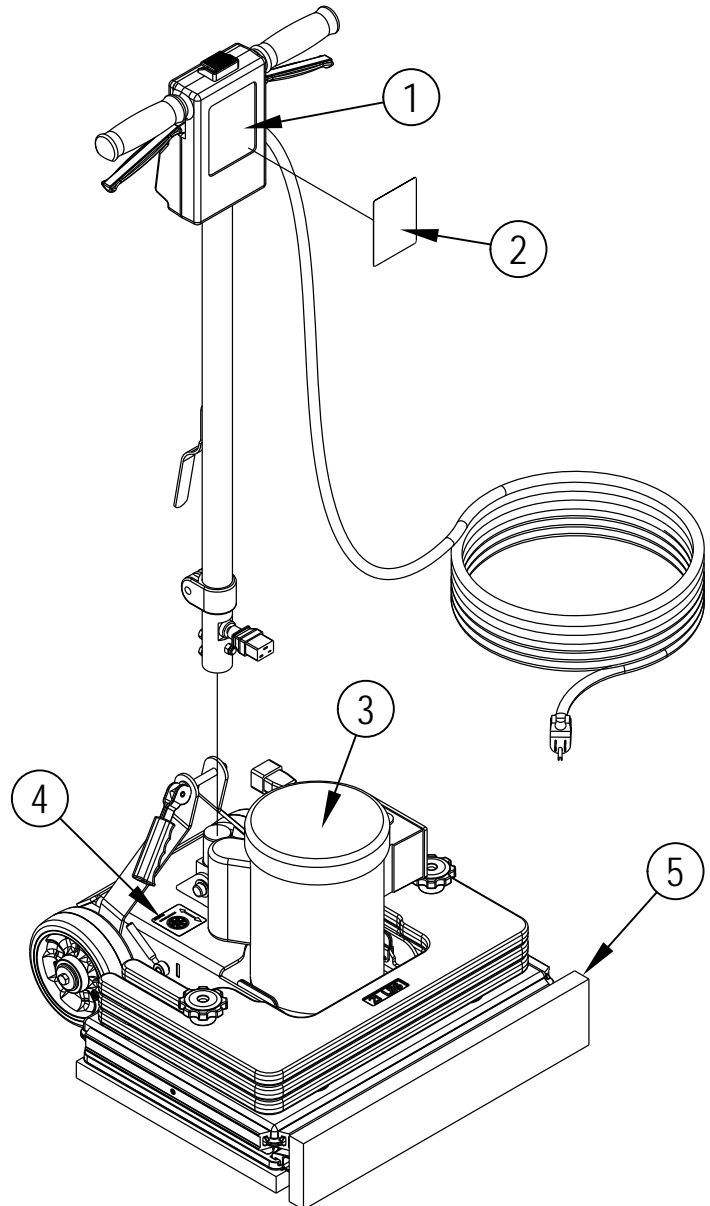

HANDLE ASSY

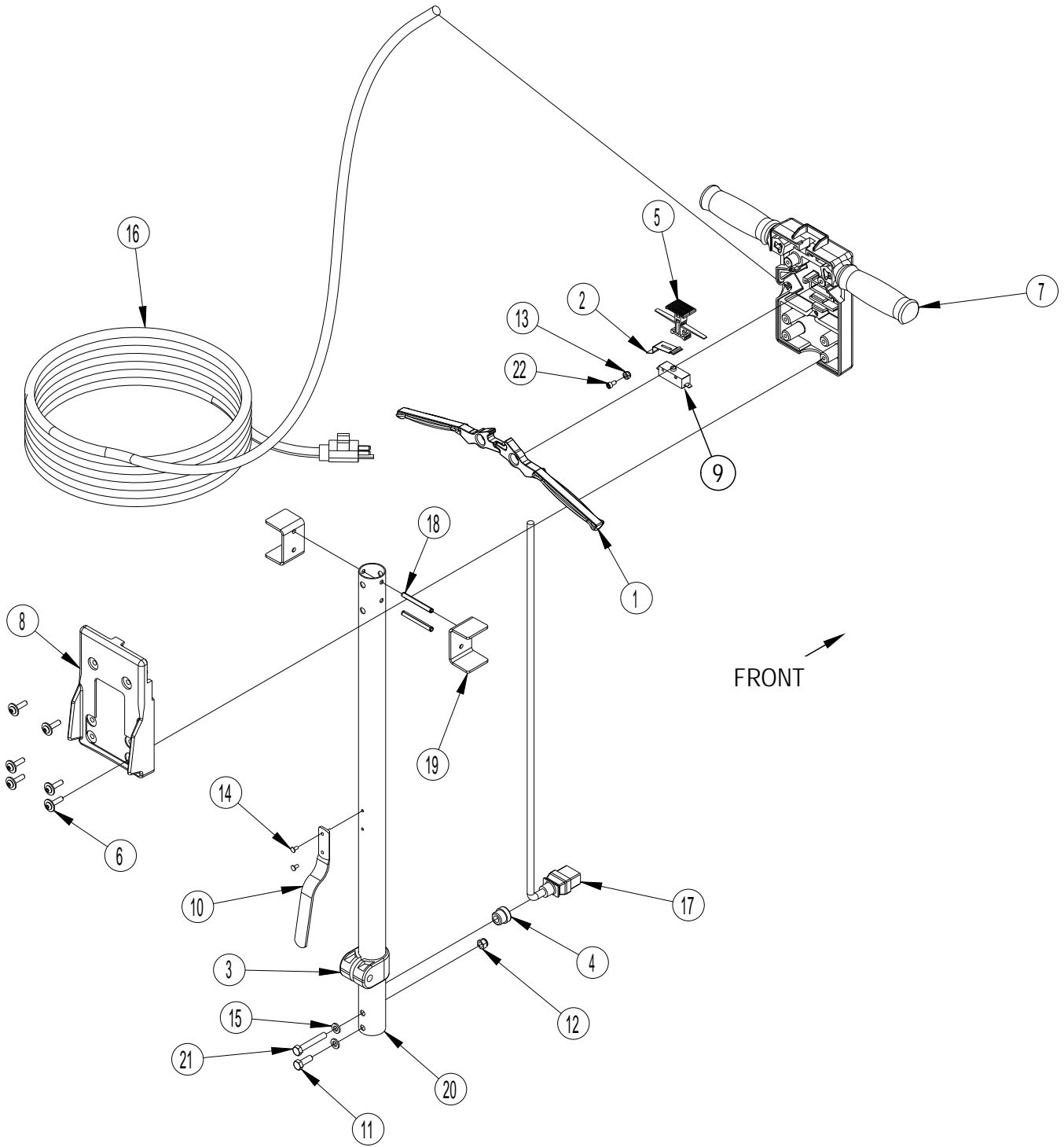

HANDLE ASSY

Item	Ref. No.	Qty	Description
1	56201027	2	Handle Lever
2	56263648	1	Spring, Plate
3	442001	1	Clamp-Handle Tube
4	627561	1	Strain-Relief
5	56201031	1	Button, Lock
6	80292A	6	Screw .25-20 X 1.00 Bhr Sems
7	56201656	1	Handle, Front
8	56201657	1	Handle, Back
9	40949A	1	Switch Spstno 25a 125vac Ulcsa
10	64325A	1	Hook-Cord
11	85812A	1	Screw 5/16-18 X 7/8 Hex Hd Gr5
12	920110	1	Nut, 5/16-18 Hex Lock
13	920722	1	Nut 10-32 Esna
14	930005	2	Rivet 5/32 X .32
15	980652	2	Washer, 5/16 Lock
16	40760A	1	Cord Power
17	56382460	1	Cord-No Relief Interconnect
18	53834A	2	Pin, Coiled
19	61726A	2	Support, Handle Mnt
20	61825A	1	Tube-Handle
21	85817A	1	Screw 5/16-18 X 2.00 Hex HD GR5
22	80290A	1	Screw 10-32 X .38 HRCS

WIRING DIAGRAM

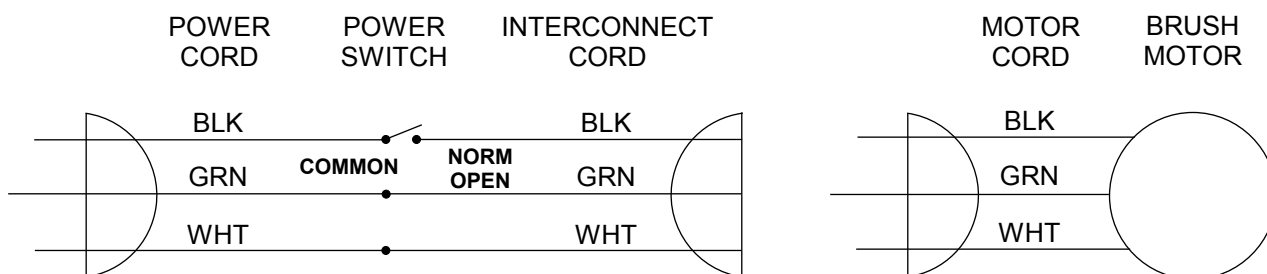

BASE ASSY-LX

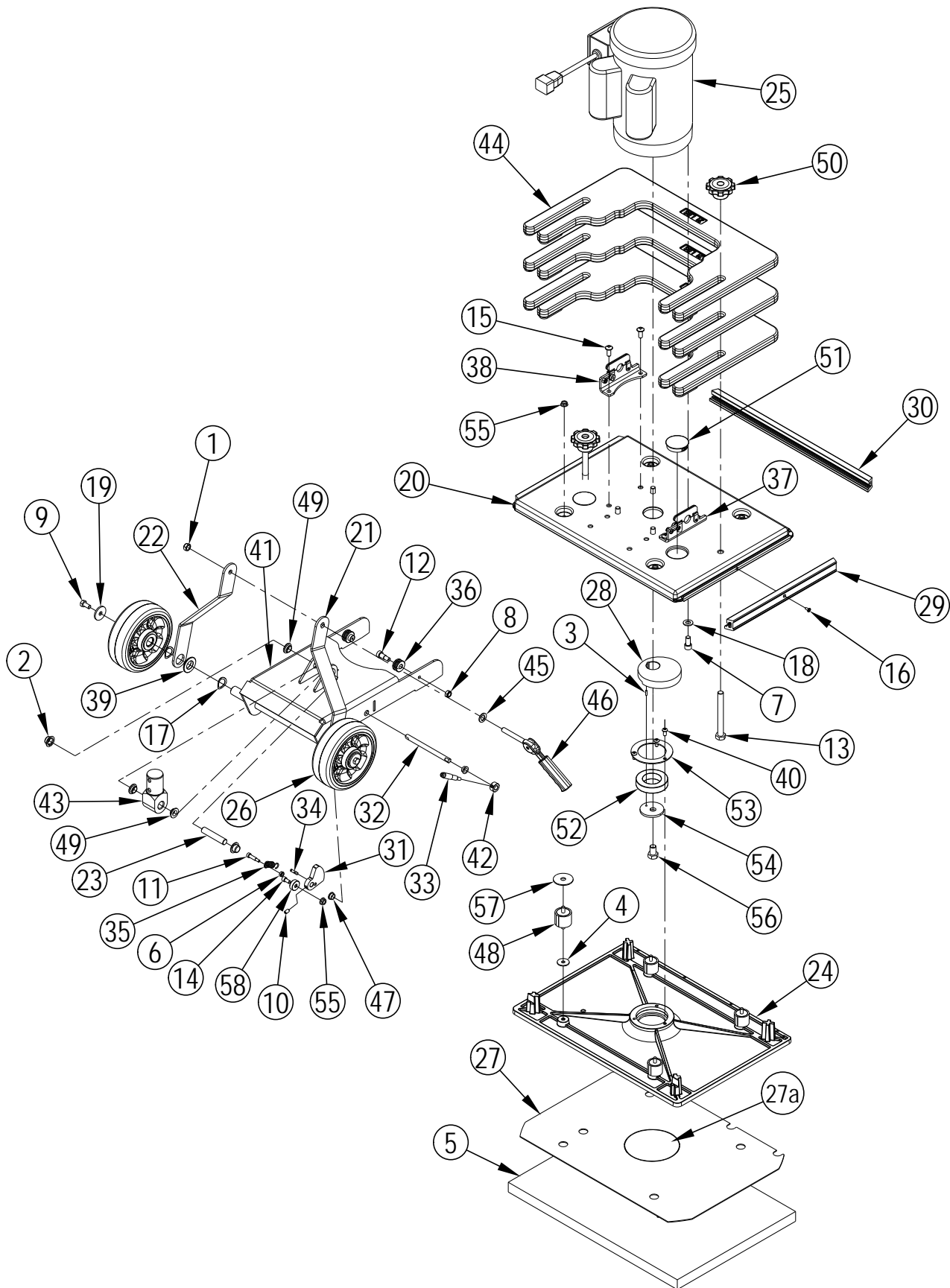

BASE ASSY-LX

Kit	Item	Ref. No.	Qty	Description
	1	56002841	1	Nut Hex Nyl Loc-Thin 3/8-16
	2	920346	2	Palnut #Pw500015 Type W
	3	925589	1	Pin, Roll
K1	4	56009002	4	Washer Flat .266x.906x.060
	5	997020	1	Boost 20 Red Pad
	6	56002832	1	Nut, Hex Nyl Loc-Thin 10-24
	7	86112A	4	Screw-3/8-16 X 3/4-socket Head
	8	56002851	2	Nut, Hex Nyl Loc-Thin Ss 5/16-18
	9	56002929	2	Scr-Hex Hd Loc 5/16-18x.62
	10	56002930	1	Scr. Soc Set Loc 1/4-20 X .38
	11	56003972	1	Scr-Soc Shd Ss .25x.75x10-24
	12	56003818	2	Scr-Soc Shd Ss .38 X .50 X 5/16-18
	13	56003910	2	Scr-Hex FT SS M12-1.75 X 110mm
	14	56002115	2	Scr Soc Hd 1/4-20 X .50
	15	56003968	4	Scr-Soc Hd 5/16-18x.75 Tapt li
	16	56003969	3	Scr-Soc Hd #8-32x.38 Tapt li
	17	56009021	4	Wsh, Bowed .781x1.062x.014
	18	56009112	4	Wsh, Int Shprf 3/8
	19	56009294	2	Wsh, Flt .354 X 1.247 X .120
	20	56105630	1	Frame-Main
	21	56105774	1	Link-Arm-Right-Lx
	22	56105773	1	Link-Arm-Left-Lx
	23	56105637	1	Pin-Handle
	24	56105639	1	Base-Orbital
	25#	56385093	1	Motor-115vac-3450rpm-1.5hp
	[]#	56385700	1	Capacitor-Start-Motor
	[]#	56385096	1	Relay-Motor-Pu115-124
	[]#	56385102	1	Capacitor-Run-Motor
	[]#	56385103	1	Switch-Thermal-Motor
	[]#	56385101	1	Cord-lec-Motor
	26	56105651	2	Wheel-2x6
	27	56105652	1	Pad-Grip Orbital-Base
K1	27a#	56105728	1	Grip-Center
	28	56105654	1	Eccentric-Ranger
	29	56105661	2	Bumper-Side

Kit	Item	Ref. No.	Qty	Description
	30	56105662	1	Bumper-Front
	31	56105665	1	Cam-Lock
	32	56105666	1	Shaft-Lift
	33	56105755	1	Lift Lever Assembly
	34	56105670	1	Pin-Groove
	35	56105671	1	Spring-Lift
	36	56105673	2	Bushing-Release
	37	56105681	1	Latch Assy-Right
	38	56105685	1	Latch Assy-Left
	39	56105694	2	Bushing-Link Arm
	40	87700A	3	Screw 1/4-20 X 1/2 B.H.
	41	56105699	1	Wheel Chassis Weldment Lx
	42	56105700	1	Collar-Shaft
	43	56105711	1	Tongue-Handle-Tube
	44	56105713	3	Weight Assembly
	45	56105727	1	Washer-Wear-Cam
	46	56109699	1	Cam Assy With Grip
	47	56303285	2	Bearing, FL .500x.375x.250
K1	48		4	Isolator-1.25 30 Duro 1/4-20
	49	56413211	4	Bearing, Flange .625 X .500 X .250
	50	56380149	2	Knob-M12-1.75 Thru
	51	56105753	2	Plug-1-3/4in Hole
	52	50736A	1	Bearing
	53	66981A	1	Retainer Bearing Obs-18
	54	66982A	1	Retainer Eccentric Obs-18
K1	55	81220A	5	Nut, Serrated Flange
	56	85718A	1	Scr 1/2-13 X 3/4 Hc St Grd 2
K1	57		4	Washer Rubber 3/8 Id X 1-1
	58	56105771	1	Stop-Cam

Service Kits

K1	56105746	1	Isolator-FM810-FM40 Kit
----	----------	---	-------------------------

[] = Not Shown

= Revised or new since last update

BASE ASSY-ST

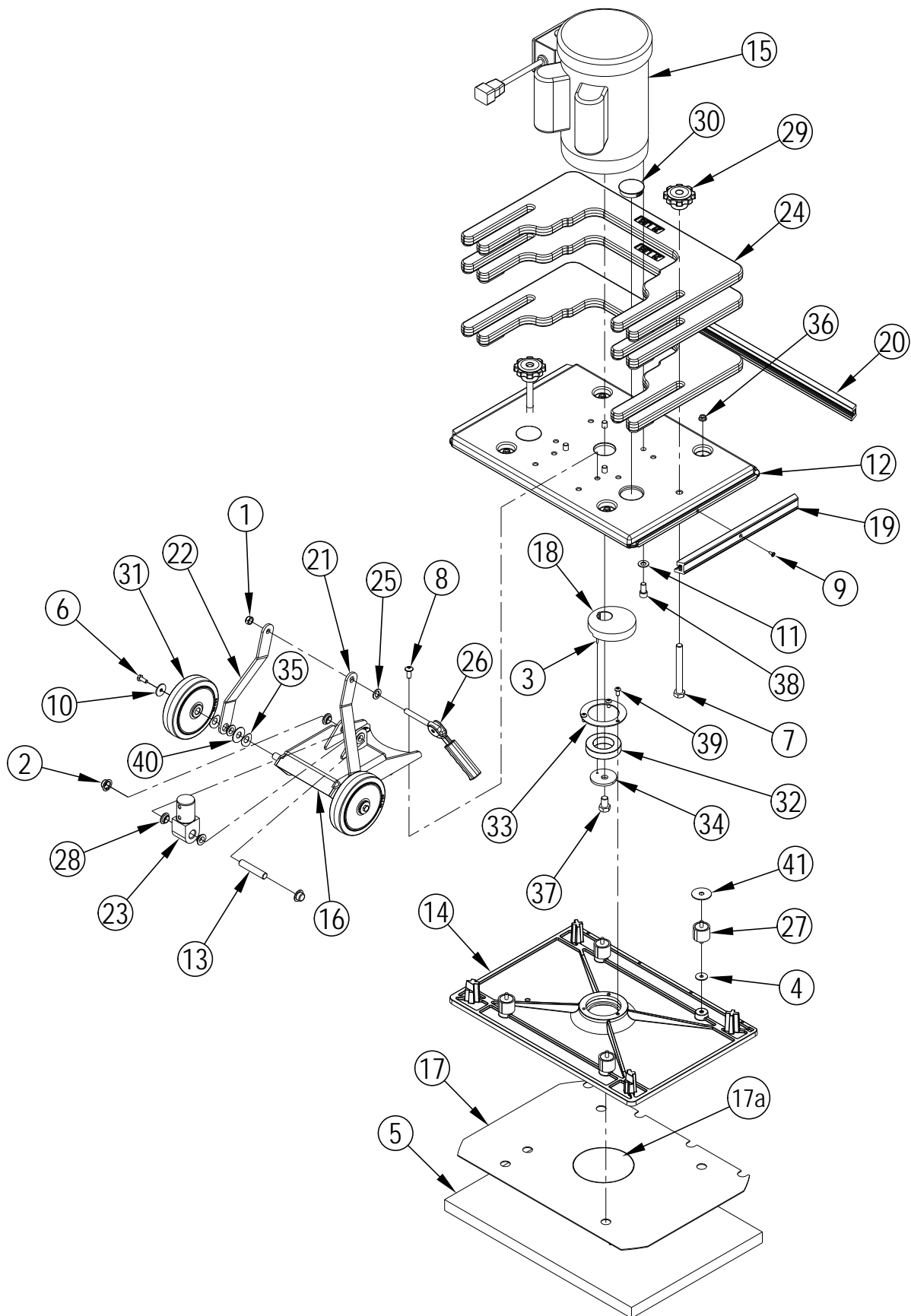

BASE ASSY-ST

Kit	Item	Ref. No.	Qty	Description
	1	56002841	1	Nut Hex Nyl Loc-Thin 3/8-16
	2	920346	2	Palnut #Pw500015 Type W
	3	925589	1	Pin, Roll
K1	4	56009002	4	Washer Flat .266x.906x.060
	5	997020	1	Boost 20 Red Pad
	6	56002922	2	Scr-Hex Hd Loc 1/4-20x.62
	7	56003910	2	Scr-Hex FT SS M12-1.75 X 110mm
	8	56003968	4	Scr-Pan Phil 5/16-18x.75 Tapt li
	9	56003969	3	Scr-Soc Hd #8-32x.38 Tapt li
	10	56009060	2	Wsh-Flt Ss .260 X 1.000 X .074
	11	56009112	4	Wsh, Int Shprf 3/8
	12	56105630	1	Frame-Main
	13	56105637	1	Pin-Handle
	14	56105639	1	Base-Orbital
	15#	56385093	1	Motor-115vac-3450rpm-1.5hp
	[]#	56385700	1	Capacitor-Start-Motor
	[]#	56385096	1	Relay-Motor-Pu115-124
	[]#	56385102	1	Capacitor-Run-Motor
	[]#	56385103	1	Switch-Thermal-Motor
	[]#	56385101	1	Cord-lec-Motor
	16	56105646	1	Wheel Chassis Weldment
	17	56105652	1	Pad-Grip Orbital-Base
K1	17a#	56105728	1	Grip-Center
	18	56105654	1	Eccentric-Ranger
	19	56105661	2	Bumper-Side
	20	56105662	1	Bumper-Front
	21	56105766	1	Link-Arm-Right
	22	56105767	1	Link-Arm-Left
	23	56105711	1	Tongue-Handle-Tube
	24	56105713	3	Weight Assembly
	25	56105727	1	Washer-Wear-Cam
	26	56109699	1	Cam Assy With Grip
K1	27		4	Isolator-1.25 30 Duro 1/4-20
	28	56413211	6	Bearing, Flange .625 X .500 X .250
	29	56380149	2	Knob-M12-1.75 Thru
	30	56105753	2	Plug-1-3/4in Hole
	31	39857A	2	Wheel 5 X 1.50 X .500
	32	50736A	1	Bearing
	33	66981A	1	Retainer Bearing Obs-18
	34	66982A	1	Retainer Eccentric Obs-18
	35	80295A	4	Washer Bowed
K1	36	81220A	4	Nut, Serrated Flange
	37	85718A	1	Scr 1/2-13 X 3/4 Hc St Grd 2
	38	86112A	4	Screw-3/8-16 X 3/4-Socket Head
	39	87700A	3	Screw 1/4-20 X 1/2 B.H.
	40	87607A	2	Washer Flt 1.25x.52x.06 Nylon
K1	41		4	Washer Rubber 3/8 Id X 1-1

Service Kits

K1 56105746 1 Isolator-FM810-FM40 Kit

[] = Not Shown

= Revised or new since last update

Clarke[®]

9435 Winnetka Ave North
Minneapolis, MN 55445

www.clarkeus.com

Phone: 800-253-0367

Fax: 800-825-2753

©2017 Nilfisk, Inc.

A Nilfisk Brand