

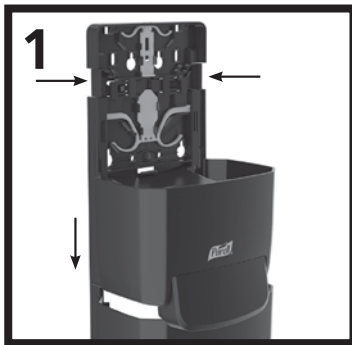

# PURELL® ES4 Dispenser Installation and Use Instructions

Please read all instructions carefully before installing and using the dispenser.

## Fastener & Tape Installation



Open dispenser by pressing release buttons on side of dispenser and slide the front cover down.

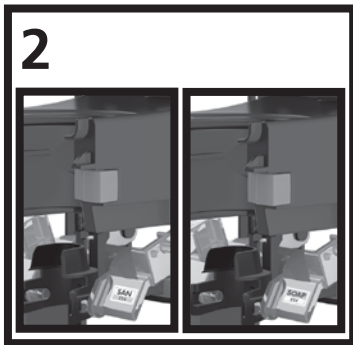

Check label inside dispenser before installing.  
ES4 SOAP = soap dispenser  
ES4 SAN = hand sanitizer dispenser

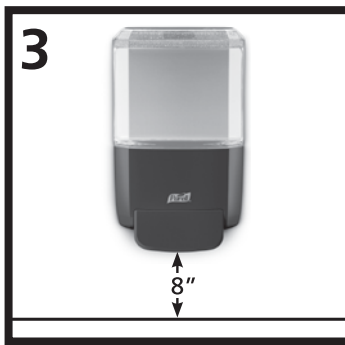

Install dispenser with at least 8" free space above counter top to allow routine service.

## If installing with wall fasteners

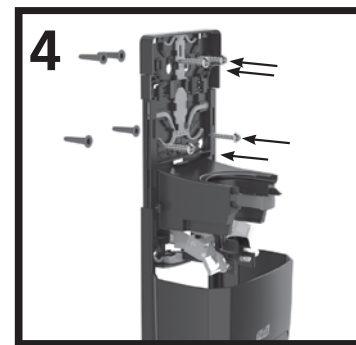

Using dispenser as a template, mark and drill four holes using 1/4" drill bit. Use the supplied #10 x 1" screws to secure the dispenser in place, being careful not to over tighten. It is recommended to use 4 screws however if only two are possible, the top two should be used.

## If installing with tape



Clean installation surface with an alcohol pad. Allow surface to dry for 60 seconds then peel paper off installation tape and press firmly on back plate for 10 seconds. For maximum adhesion, wait 24 hours before loading refill or applying significant force.



Attach the back cover by pressing on the top two corners and the bottom middle section.

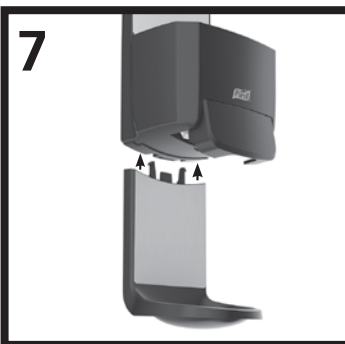

Install the SHIELD™ Floor and Wall Protector into the bottom of the dispenser by aligning plastic tabs on the Shield with slots on the dispenser and sliding up until the tabs snap into place. (Shield is included with Sanitizer Systems and can be ordered for Soap systems).  
7745-WHT-18 White SHIELD Floor and Wall Protector  
7745-GPH-18 Graphite SHIELD Floor and Wall Protector

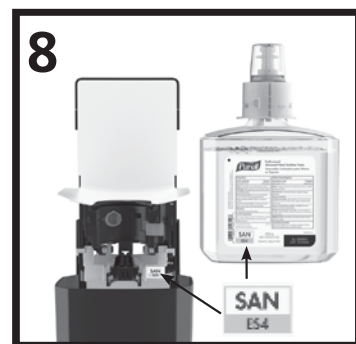

Match label on refill with label on dispenser.

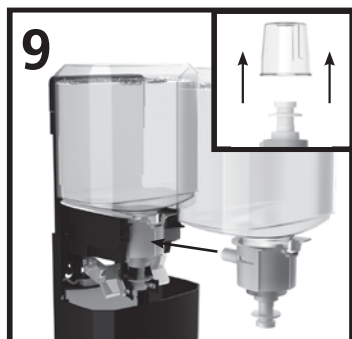

Remove refill cap and push the new refill into dispenser until it clicks in place. Close dispenser cover.



Place hand in middle of bar and push, product will dispense as bar is depressed.

## Refill Installation



1  
Open dispenser by pressing release buttons on side of dispenser and slide the front cover down.

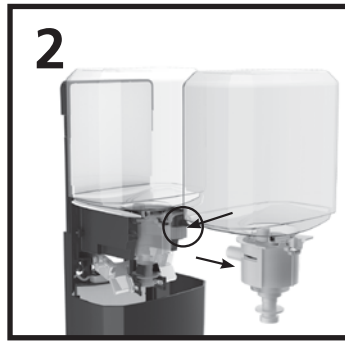

2  
Push Release button and remove empty refill.

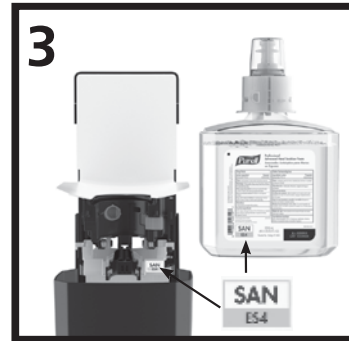

3  
Match label on refill with label on dispenser.

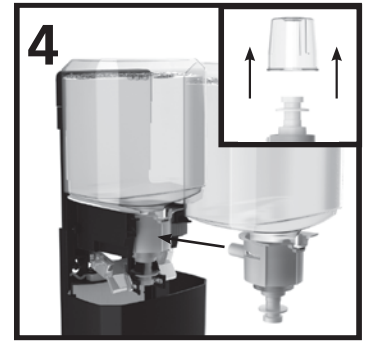

4  
Remove refill cap and push the new refill into dispenser until it clicks in place.

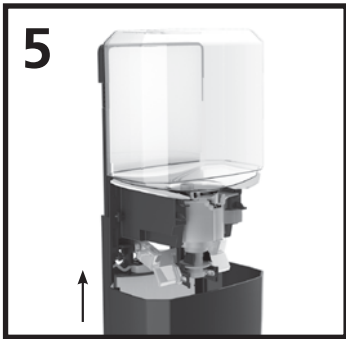

5  
Close dispenser cover.



6  
Place hand in middle of bar and push, product will dispense as bar is depressed.

## Disposal/Recycling

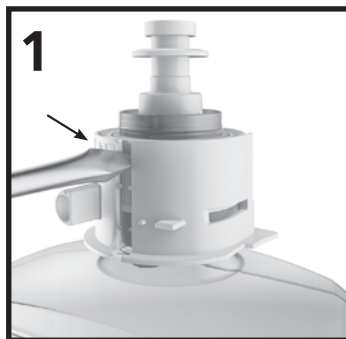

1  
Insert a flat blade screwdriver into the slots on the refill collar and twist to separate the collar from the refill. Unscrew the pump from the bottle and discard.



2  
Separate the refill pump from the recyclable PET Bottle. Dispose/Recycle the PET Bottle and Collar.

## LOCK OR NOT™ Technology - Locking

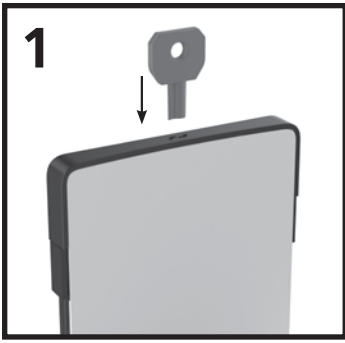

Lock the dispenser by aligning the key with the key hole on the top of the dispenser and push down until a click is heard.

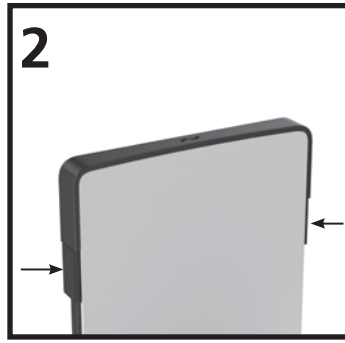

Check for a successful lock by pressing the release buttons on side of dispenser to see if the front cover releases and slides down. Once locked, the dispenser will remain in the locked state.  
To open a locked dispenser, insert the key into the key holder and press down until the front cover is released.

## LOCK OR NOT Technology - Unlocking

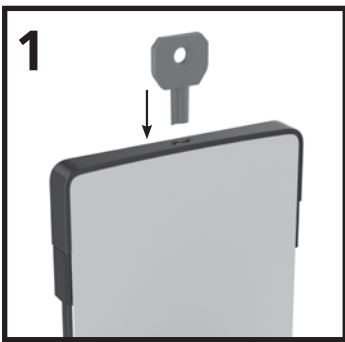

Open a locked dispenser by inserting the key into the key hole on the top of the dispenser to release the front cover.

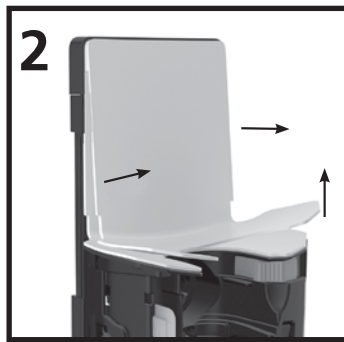

Remove the back cover.

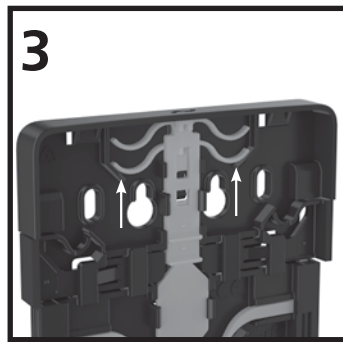

Restore to the unlocked position by pushing the locking mechanism toward the top of the dispenser.



Attach the back cover by pressing on the top two corners and the bottom middle section.

## TRUE FIT™ & MESSENGER™ Dispenser Station Installation

The TRUE FIT & MESSENGER Station are optional accessories that can be utilized with the dispensing systems and ordered with:

- 7740-WHT-18 TRUE FIT Wall Plate - White
- 7740-GPH-18 TRUE FIT Wall Plate - Graphite
- 7741-WHT-18 TRUE FIT Wall Plate + MESSENGER Dispenser Station - White
- 7741-GPH-18 TRUE FIT Wall Plate + MESSENGER Dispenser Station - Graphite

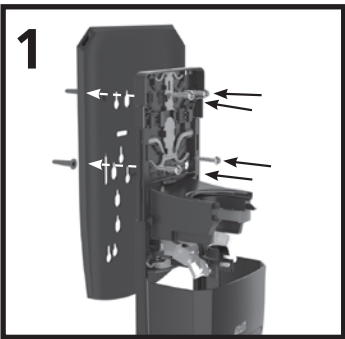

Install the TRUE FIT wall plate at the designated anchor holes.

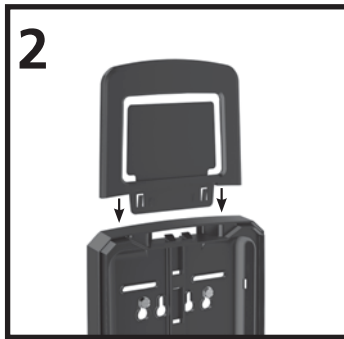

Slide two prongs at the bottom of the MESSENGER Dispenser Station into the inlet holes above TRUE FIT Wall Plate until they set in. The MESSENGER Dispenser Station accepts a standard 3" x 4" clear name badge holder with a 3" x 4" name badge card that can be ordered from most office supply vendors. Print a message on a 3" x 4" name badge card and insert the message between the frame and back with message facing out.



GOJO Industries, Inc.  
One GOJO Plaza, Suite 500  
P.O. Box 991 • Akron, OH. 44309-0991  
Tel: 1-330-255-6000 • Toll-free: 1-800-321-9647  
Fax: 1-800-FAX-GOJO