

Advenger™

2800ST, 3400ST

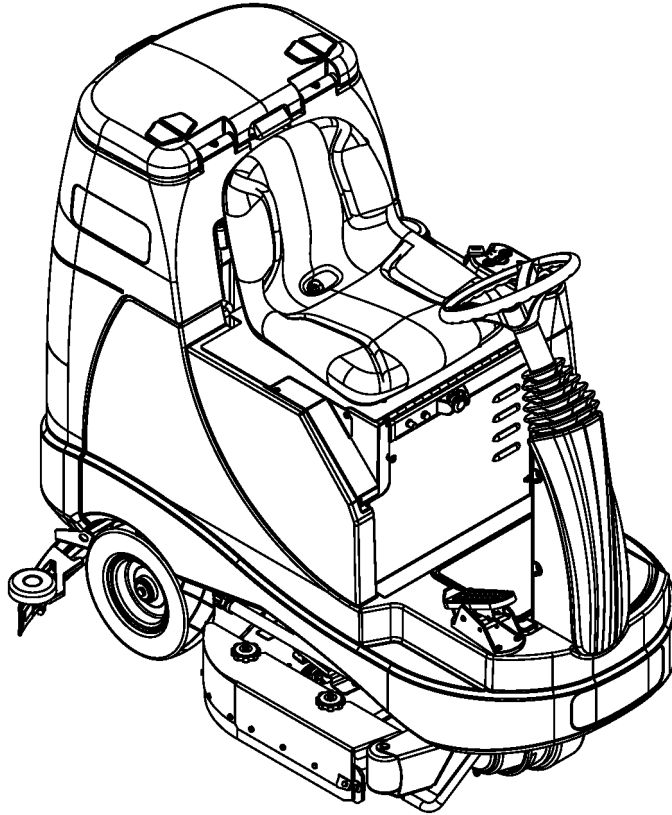

PARTS LIST

**Advance MODELS 56601000, 56601001, 56601002, 56601003, 56601004
56601005, 56601006, 56601007, 56601008, 56601009, 56601010, 56601011
56601012, 56601013, 56601019, 56601020**



Advance

DESCRIPTION	PAGE
Chassis System-STD / AXP	2-3
Chassis System-ST	4-5
Control System	6-7
Decal System.....	8-9
Electrical System	10-11
Onboard Charger Assembly	12-13
Recovery System.....	14-15
Scrub System-Cylindrical.....	16-17
Scrub System-Cylindrical-Skirt Assemblies	18-19
Scrub System-28" Disk	20-21
Scrub System-34" Disk	22-23
Scrub System-Disk- Skirt Assemblies.....	24-25
Solution System-AXP.....	26-27
Solution System-STD	28-29
Solution System-ST	30-31
Squeegee System-STD / AXP	32-33
Squeegee System-ST.....	34-35
Squeegee Assembly	36-37
Wiring Diagram-STD / AXP.....	38-39
Wiring Diagram-ST	40-41
Optional Kits and Accessories	42
Brush Selector Guide-Disk	43
Brush Selector Guide-Cylindrical.....	44

WHEN ORDERING PARTS

- * Use the part numbers from the "Ref. No." columns in this parts list.
- * Specify the model and serial number of the machine.
- * Use the space below to record the model and serial number for future reference.

Model _____ Serial No. _____

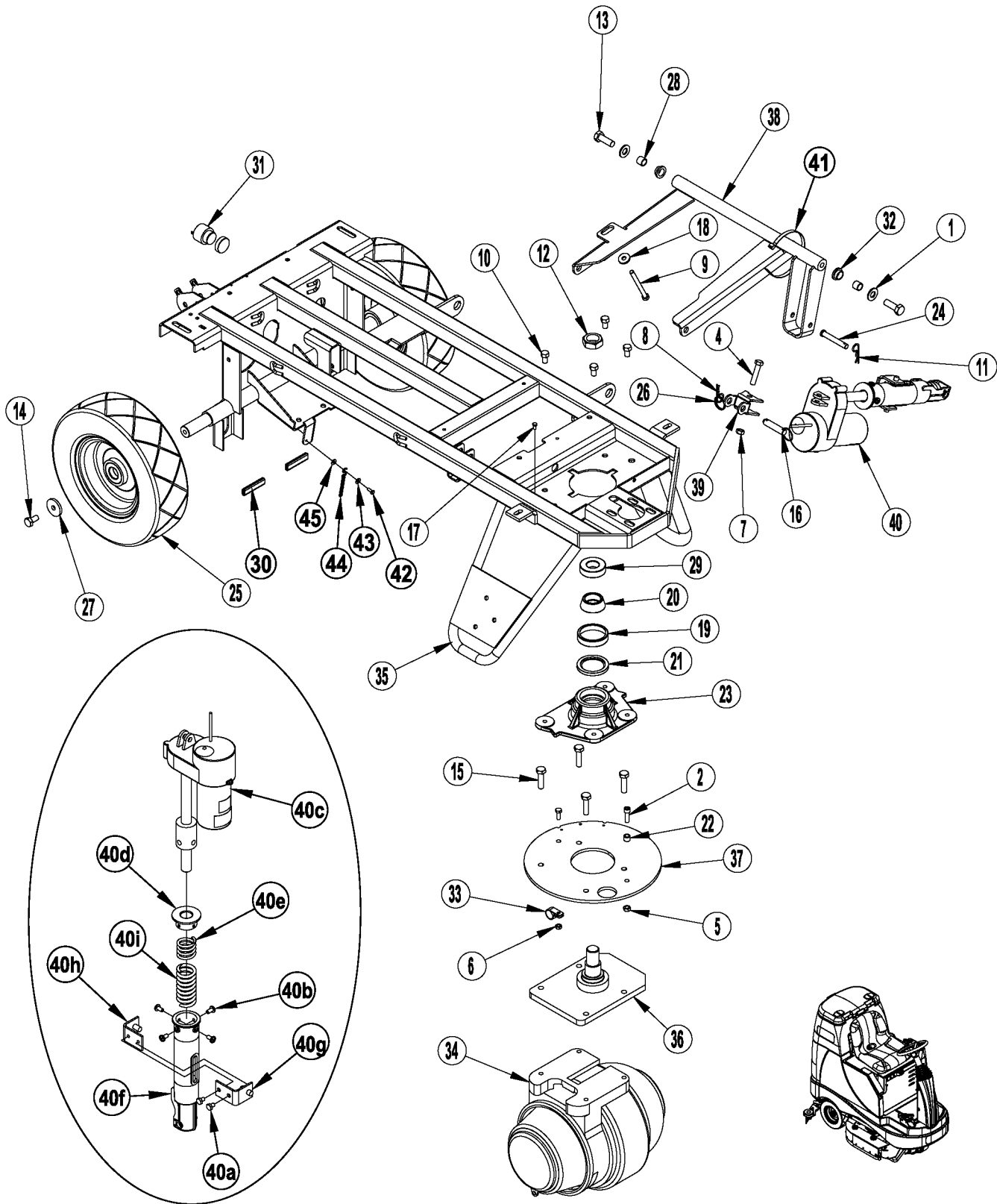

Item	Ref. No.	Qty	Description	Item	Ref. No.	Qty	Description
1	56001879	2	Wsh, Flt Sae 1/2	34	56601050	1	Motor / Drive Wheel (M1)
2	56002129	1	Scr, Soc Hd 5/16-18 X 1.00	[]	56601472	1	Tire With Hub
3	56002155	1	Scr, Hex 1/4-20 X .75	[]	56601473	1	Motor
4	56002684	1	Scr, Hex 3/8-16 X 1.75	[]	56601509	1	Carbon Brush Kit
5	56002826	1	Nut, Hex Nyl Loc-Thin 5/16-18	[]	56601471	1	Tire
6	56002840	1	Nut, Hex Nyl Loc-Thin 1/4-20	[]	56601507	1	Electromagnetic Brake
7	56002841	1	Nut, Hex Nyl Loc-Thin 3/8-16	[]	56422174	1	Tire Puller Kit
8	56002959	1	Pin, Cotter Hair	[]	56601506	1	Drive Motor Cover
9	56003008	1	Scr, Hex Thd To Hd 5/16-18 X 3.50	35	56601073	1	Chassis, Weldment
10	56003040	4	Scr, Hex Hd Loc 3/8-16x.62	36	56601077	1	Spindle Weldt
11	56003120	1	Pin, Cotter Hair .0915 X .375	37	56601159	1	Plate, Steering
12	56003220	1	Nut, Hex Nyl Loc-Thin 1-14	38	56601239	1	Deck Linkage, Weldt
13	56003412	2	Scr, Hex Loc M12-1.75 X 35mm	39	56601328	1	Yoke, Actuator
14	56003442	2	Scr, Hex Loc M10-1.5 X 20mm	40	56601432	1	Lift Actuator Assembly (M4)
15	56003491	4	Scr, Hex M10-1.5 X 40mm	40a	56009019	2	Scr, Hex Thd Form 1/4-20 X .38
16	56003679	1	Pin, Ring .50 X 1.63	40b	56009062	4	Scr, Pan Phil Thd Form 1/4-20 X .50
17	56009012	1	Scr, Hex Thd Form 10-24 X .38	40c	56393303	1	Actuator, Motor
18	56009122	1	Wsh, Flt .344 X .938 X .125	40d	56396268	1	Spring Housing Guide
19	56158143	1	Bearing Cup	40e	56412071	1	Compression Spring
20	56158151	1	Bearing Cone	40f	56412262	1	Housing, Spring
21	56171081	1	Seal, Shaft	40g	56420019	1	Nut Retainer
22	56244941	1	Bushing	40h	56420020	1	Nut Retainer
23	56314032	1	Block, Bearing	40i	56601470	1	Compression Spring
24	56003803	1	Pin-Clevis SS .375 x 2.50	41	56477613	1	Tie-Cable
25	56601482	2	Wheel	42#	56009039	1	Scr, Hex Thd Form 10-24 x .50
26	56317071	1	Ring	43#	56001954	1	Wsh, Flt SAE 10
27	56367117	2	Wsh, Flt .406 X 1.5 X .1875	44#	56601716	1	Ground Chain
28	56367206	2	Bushing	45#	56009011	1	Wsh, Int Shprf 10
29	56378380	1	Bearing Ball	46#	56009112	1	Wsh, Int Shprf 3/8
30	56412122	2	Trim Edge				
31	56412177	1	Horn/Backup Alarm (H2)				
32	56420160	2	Bearing, Flange				
33	56486112	1	Clamp, P				

[] = Not Shown

= Revised or new since last update

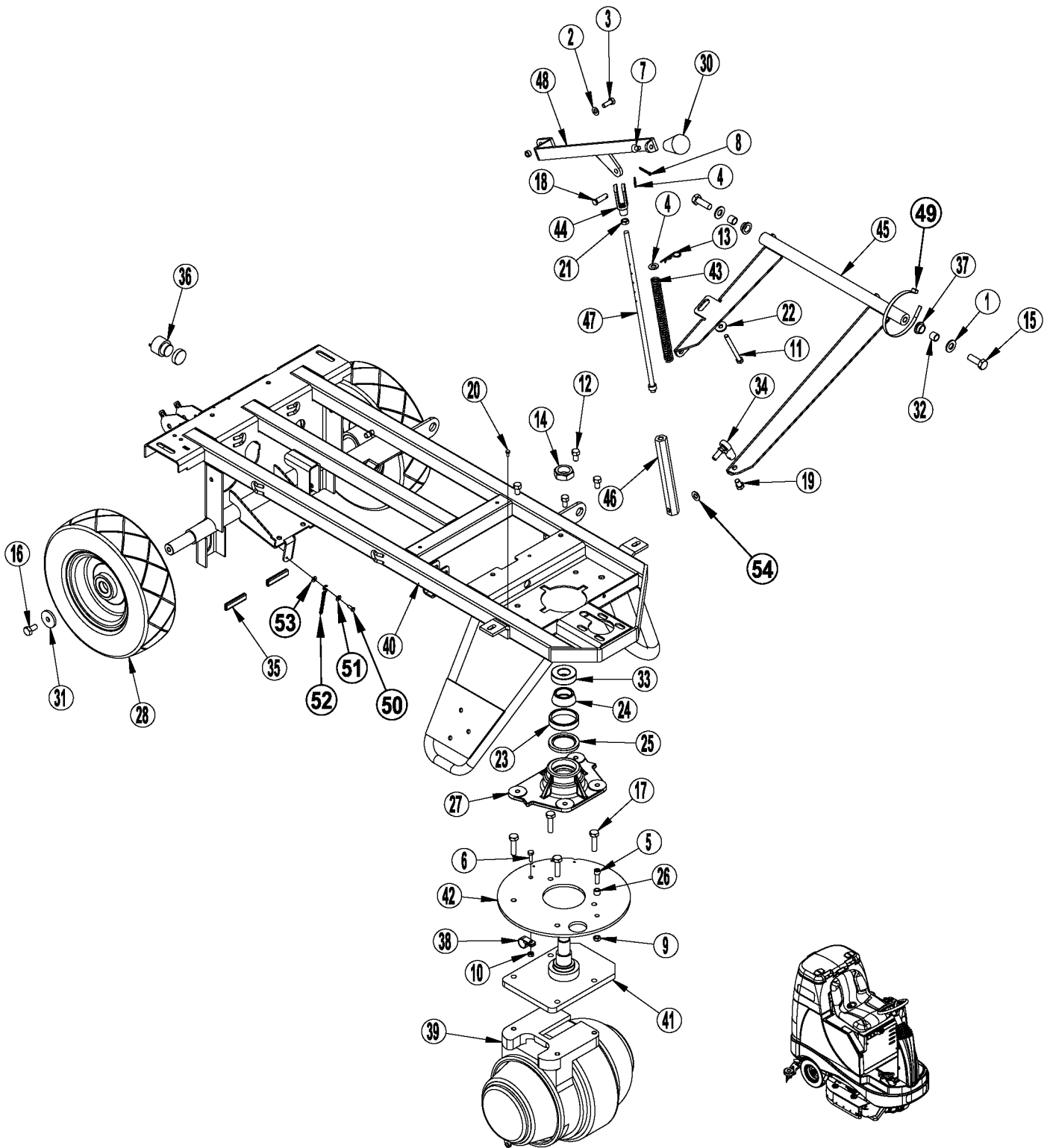

Item	Ref. No.	Qty	Description	Item	Ref. No.	Qty	Description
1	56001879	2	Wsh, Flt Sae 1/2	31	56367117	2	Wsh, Flt .406 X 1.5 X .1875
2	56001939	1	Wsh, Flt Sae 5/16	32	56367206	2	Bushing
3	56002037	1	Scr, Hex 5/16-18 X .88	33	56378380	1	Bearing Ball
4	56002063	2	Wsh, Flt Sae 3/8	34	56397385	1	Rod End
5#	56002129	1	Scr, Soc Hd 5/16-18 X 1.00	35	56412122	2	Trim Edge
6	56002155	1	Scr, Hex 1/4-20 X .75	36	56412177	1	Horn/Backup Alarm (H2)
7	56002476	1	Scr, Flt Phil 5/16-18 X .62	37	56420160	2	Bearing, Flange
8	56002529	1	Pin,Cotter 1/8 X 1	38	56486112	1	Clamp,P
9	56002826	1	Nut, Hex Nyl Loc-Thin 5/16-18	39	56601050	1	Motor / Drive Wheel (M1)
10	56002840	1	Nut, Hex Nyl Loc-Thin 1/4-20	[]	56601472	1	Tire With Hub
11	56003008	1	Scr, Hex Thd To Hd 5/16-18 X 3.50	[]	56601473	1	Motor
12	56003040	4	Scr,Hex Hd Loc 3/8-16x.62	[]	56601509	1	Carbon Brush Kit
13	56003120	1	Pin, Cotter Hair .0915 X .375	[]	56601471	1	Tire
14	56003220	1	Nut, Hex Nyl Loc-Thin 1-14	[]	56601507	1	Electromagnetic Brake
15	56003412	2	Scr, Hex Loc M12-1.75 X 35mm	[]	56422174	1	Tire Puller Kit
16	56003442	2	Scr, Hex Loc M10-1.5 X 20mm	[]	56601506	1	Drive Motor Cover
17	56003491	4	Scr, Hex M10-1.5 X 40mm	40	56601073	1	Chassis, Weldment
18	56003589	1	Pin, Clevis .375 X 1.25	41	56601077	1	Spindle Weldt
19	56003674	1	Scr, Hex Loc Ss 3/8-24 X .62	42	56601159	1	Plate, Steering
20	56009012	1	Scr, Hex Thd Form 10-24 X .38	43	56601293	1	Spring, Comp
21	56009103	1	Nut, Hex Jam 3/8-24	44	56601342	1	Yoke, .375-24
22	56009122	1	Wsh, Flt .344 X .938 X .125	45	56601354	1	Linkage, Weldt
23	56158143	1	Bearing Cup	46	56601356	1	Connecting Rod
24	56158151	1	Bearing Cone	47	56601358	1	Connecting Rod Weldt
25	56171081	1	Seal,Shaft	48	56601381	1	Lift Lever Weldt
26	56244941	1	Bushing	49	56477613	1	Tie-Cable
27	56314032	1	Block, Bearing	50#	56009039	1	Scr, Hex Thd Form 10-24 x .50
28	56601482	2	Wheel	51#	56001954	1	Wsh, Fit SAE 10
29	56320595	1	Bushing .32x.50x.28	52#	56601716	1	Ground Chain
30	56364527	1	Knob	53#	56009011	1	Wsh, Int Shprf 10
				54#	56009112	1	Wsh, Int Shprf 3/8

[] = Not Shown

= Revised or new since last update

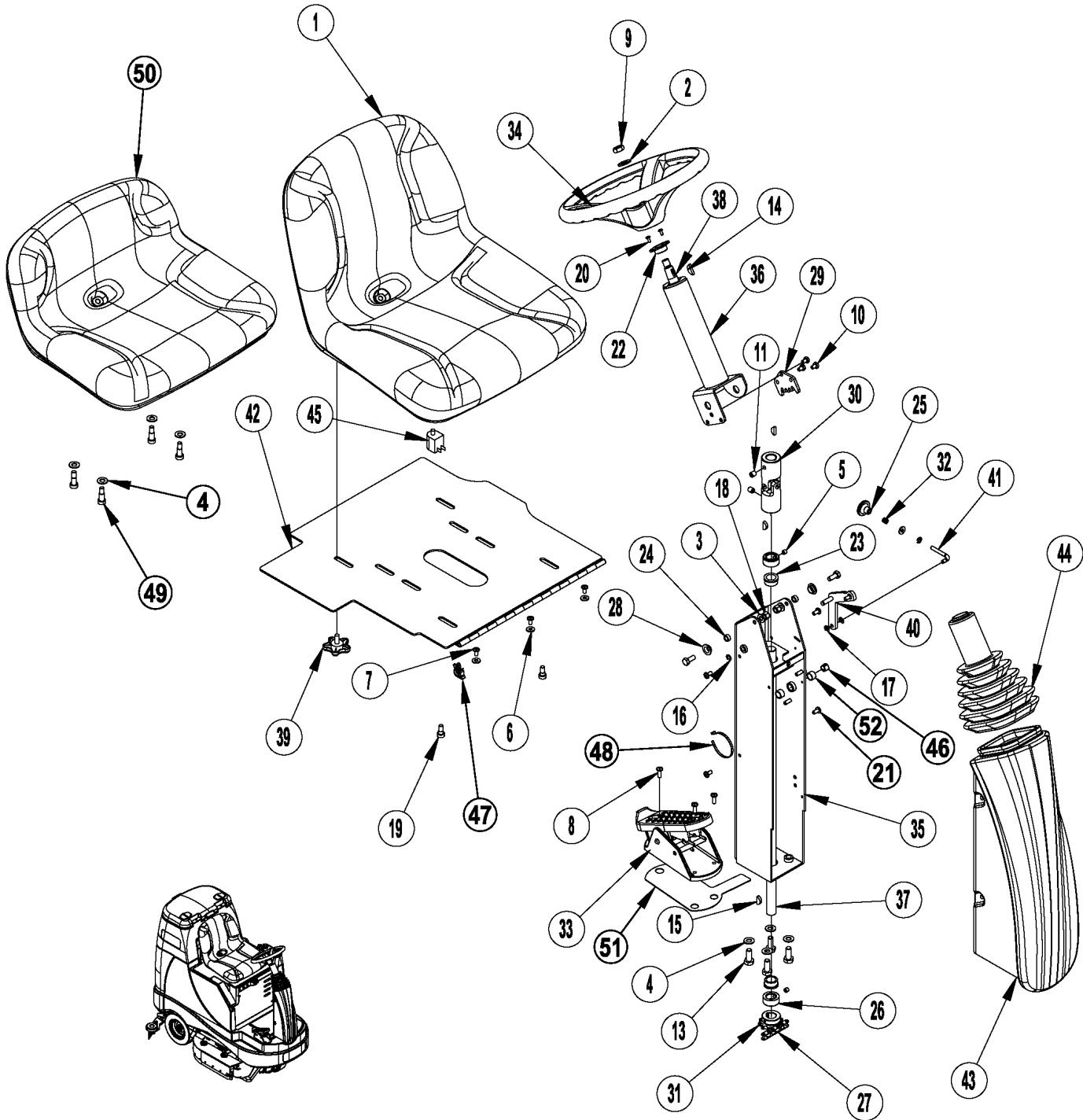

Item	Ref. No.	Qty	Description
1	8-69-00022	1	Seat (STD/AXP)
2	56001879	1	Wsh, Flt Sae 1/2
3	56001939	2	Wsh, Flt Sae 5/16
4#	56002063	4	Wsh, Flt Sae 3/8 (qty of 8 on ST)
5	56002086	2	Scr, Soc Set Loc 5/16-18 X .25
6	56002098	4	Wsh, Flt Sae 1/4
7	56002145	3	Scr, Pan Phil 1/4-20 X .50
8	56002507	3	Scr, Pan Phil 1/4-20 X .75
9	56002843	1	Nut, Hex Nyl Loc-Thin 1/2-13
10	56002933	3	Scr,Hex Hd Loc 1/4-20x.38
11	56003081	2	Scr, Soc Set Loc 3/8-16 X .38
12	56003179	2	Scr, Hex Thd To Hd M8-1.25 X 20mm
13	56003186	4	Scr, Hex Thd To Hd M10-1.5 X 25mm
14	56003227	1	Key, Wdf .62 X .19
15	56003228	3	Key, Wdf .75 X .19
16	56003261	1	Ring, Ret Ext Type E 0.31 Dia
17	56003268	3	Ring, Ret Ext Type E Reinf. 0.25 Dia
18	56003389	2	Nut, Hex Nyl Loc M8-1.25
19	56003730	3	Scr, Soc Shd .38 X .25 X 5/16-18 (STD/AXP)
20	56009051	2	Scr, Pan Phil Thd Form 8-32 X .38
21	56009062	4	Scr, Pan Phil Thd Form 1/4-20 X .50
22	56100393	1	Bushing
23	56250414	2	Bearing, Flange
24	56320595	2	Bushing .32x.50x.28
25	56362778	1	Knob
26	56367095	2	Collar, Shaft
27	56412198	1	Chain, Roller
28	56413211	2	Bearing, Flange .625 X .500 X .250
29	56413658	1	Ratchet, Steering Column
30	56454081	1	Universal Joint
31	56471148	1	Sprocket
32	56578222	1	Spring, Compression
33	56601052	1	Foot Pedal Assy
34	56601060	1	Steering Wheel
35	56601163	1	Lower Column Weldment
36	56601169	1	Upper Column Weldment
37	56601223	1	Shaft, Lower Steering
38	56601224	1	Shaft, Upper Steering
39	56601271	1	Knob, 5/16 Stud (STD/AXP)
40	56601284	1	Steering Pawl Weldment
41	56601292	1	Pull Lever
42	56601362	1	Seat Panel Weldment
43	56601484	1	Shroud, Lower Column
44	56601500	1	Boot, Steering
45	7-82-00050	1	Switch (S2)
46	56601683	1	Plug-Cap (STD/AXP)
47	56386407	1	Clip-Conduit
48	56478246	1	Tie, Cable (ST)
49	56002962	4	Scr, Soc Shd .38 x .62 x 5/16-18 (ST)
50	56601149	1	Seat, Low Back (ST)
51	56601601	1	Foot Pedal Plate
52	56366633	2	Bearing-Sleeve (ST)

= Revised or new since last update

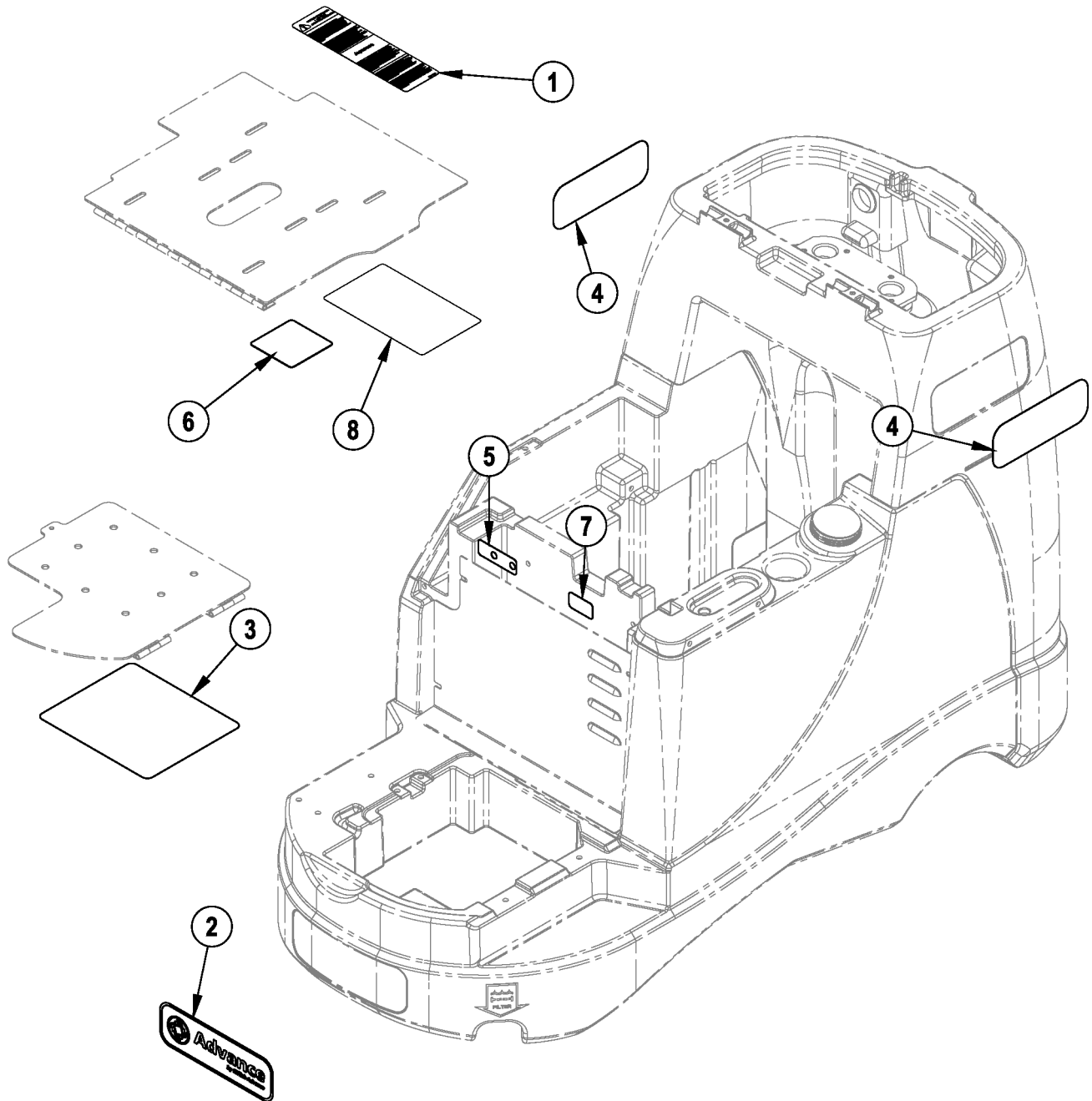

08-11

DECAL SYSTEM

09-3

Advenger™**9**

Item	Ref. No.	Qty	Description
1	56014601	1	Decal, Caution
2	56016730	1	Decal, Advance
3	56601176	1	Decal, Ladder Diagram (STD / AXP)
	56601178	1	Decal, Ladder Diagram (ST)
4	56601298	2	Decal, 2800 ST (ST)
	56601299	2	Decal, 3400 ST (ST)
#	56601300	2	Decal-Advenger (STD)
#	56601301	2	Decal-Advenger AXP (AXP)
5	56601414	1	Decal, Circuit Breaker
6	56601416	1	Decal, Battery Wiring
7	56601418	1	Decal (ST)
8	56601579	1	Decal-Error Codes (STD / AXP)

= Revised or new since last update

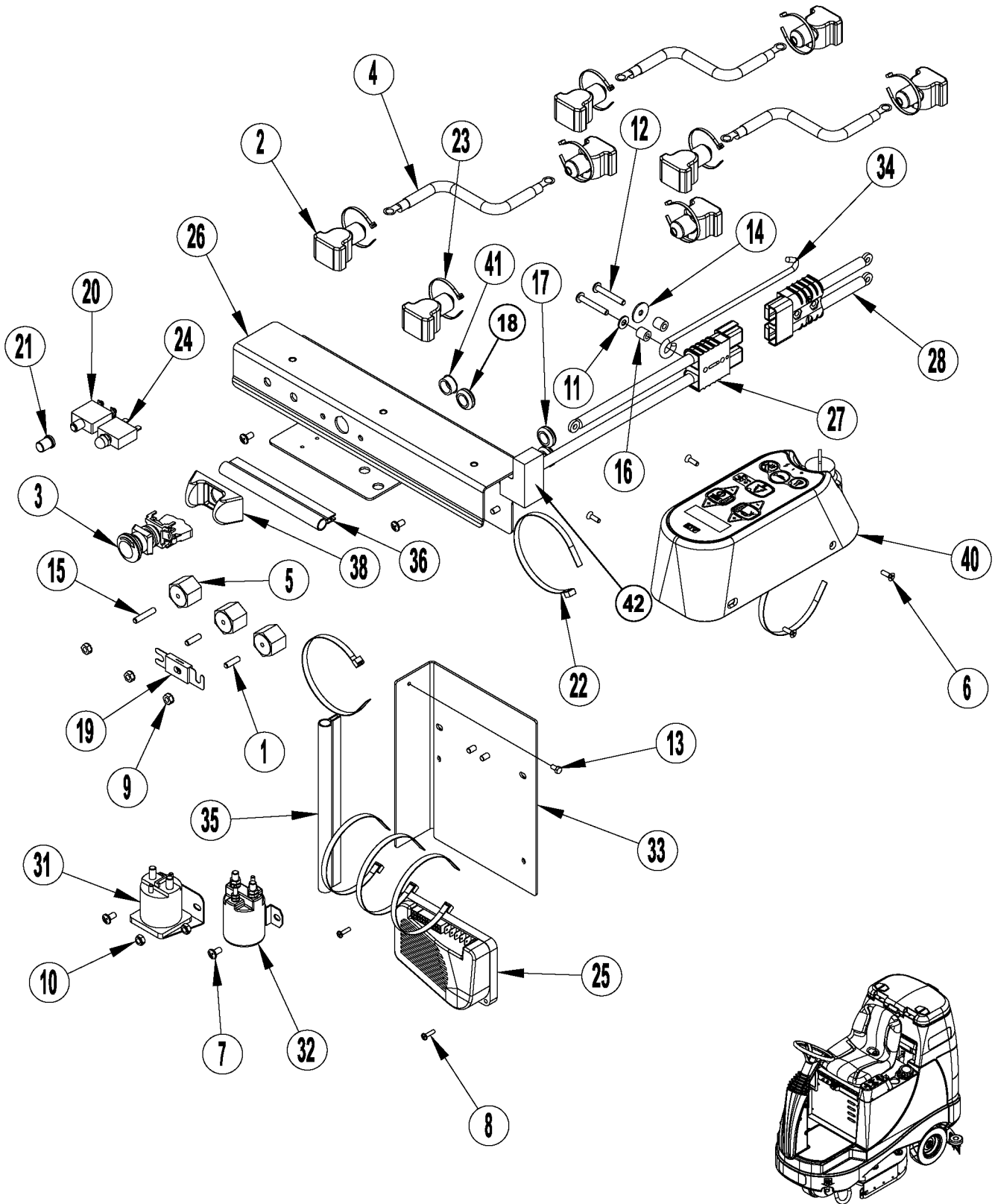

Item	Ref. No.	Qty	Description
1	56009020	2	Stud
2	56372673	8	Boot, Battery Post
3	56407130	1	Disconnect, Emergency (S4)
4	56409485	3	Cable,Battery
5	56469858	3	Electrical Mount
6	56002099	4	Scr, Flt Phil 10-24 X .62
7	56002145	4	Scr, Pan Phil 1/4-20 X .50
8	56002146	2	Scr, Pan Phil 8-32 X .62
9	56002561	3	Nut, Hex W/ Shprf 1/4-20
10	56002840	2	Nut, Hex Nyl Loc-Thin 1/4-20
11	56002859	1	Wsh, Flt Sae Ss 1/4
12	56002997	2	Scr, Pan Phil 1/4-20 X 1.75
13	56009012	1	Scr, Hex Thd Form 10-24 X .38
14	56009060	2	Wsh, Flt Ss .260 X 1.000 X .074
15	56009203	1	Stud, 1/4-20
16	56046309	2	Spacer, Phenolic
17#	56157376	2	Grommet
18	56321540	1	Grommet (STD/AXP)
#	56157376	1	Grommet (ST)
19	56412089	1	Fuse, 150 Amp (F1)
20	56454429	1	Circuit Breaker, 70 Amp (CB1)
21	56459369	1	Boot, Reset Button
22#	56477613	9	Tie, Cable
23#	56478246	9	Tie, Cable
24	56507644	1	Circuit Breaker, 10 Amp (CB2)
25	56601061	1	Speed Control (A2)
26	56601105	1	Panel (STD/AXP)
	56601420	1	Panel (ST)
27	56601171	1	Connector Assy
28	56601172	1	Connector Assy
[29]	56601174	1	Main Harness (STD/AXP)
[]	56601323	1	Main Harness (ST)
[30]	56601175	1	Traction Drive Harness
31	56601183	1	Contactactor 24v, 100 Amp (K1)
32	56412179	1	Contactactor 24v (K2)
33	56601185	1	Panel
34	56601215	1	Prop Rod, Seat
35	56601251	1	Gasket
36	56601252	1	Gasket
[37]	56601431	1	Cable, Jumper
38	56601434	1	Emergency Button Guard
39#			DELETED
40	56601565	1	Interface Panel Assy (STD/AXP) (A1)
[]	56601096	1	Kit, Interface Panel (STD/AXP)
[]	56303553	1	Key Switch (S1)
[]	56303526	A/R	Replacement Key Set
40	56601566	1	Interface Panel Assy (ST) (A1)
[]	56601097	1	Kit, Interface Panel (ST)
[]	56303553	1	Key Switch (S1)
[]	56303526	A/R	Replacement Key Set
41	56900144	1	Plug, Cap
42	56601600	1	Foam Insert

[] = Not Shown

= Revised or new since last update

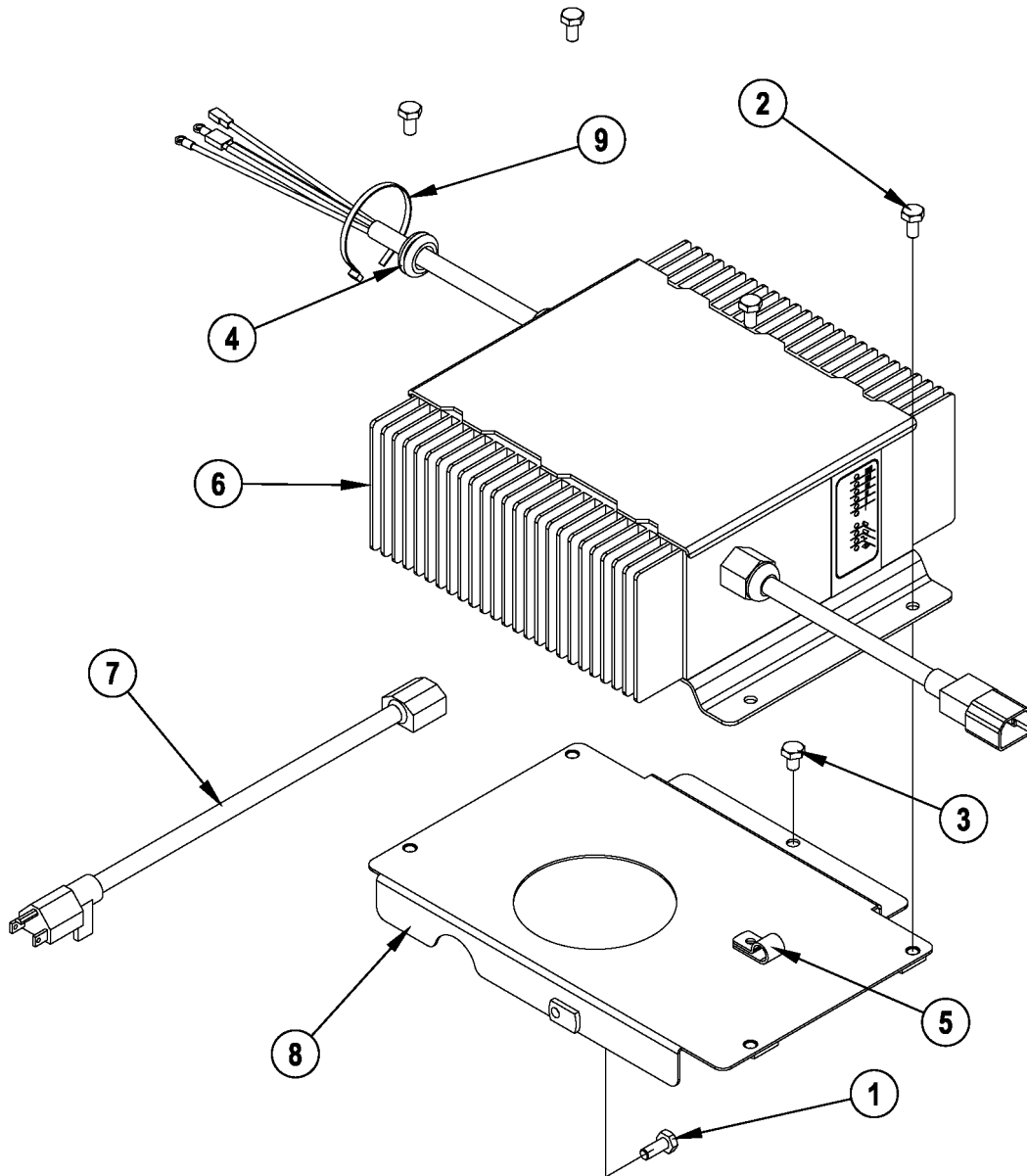

08-11

ONBOARD CHARGER ASSEMBLY

09-1

Advenger™**13**

Item	Ref. No.	Qty	Description
	56601095	1	Onboard Charger Assembly NOTE 1 / TSBUS2008-984
1	56001836	1	Scr, Hex 1/4-20 X .62
2	56001854	4	Scr, Hex 1/4-20 X .50
3	56009019	1	Scr, Hex Thd Form 1/4-20 X .38
4	56157376	1	Grommet
5	56172017	1	Clamp,P
6	56315124	1	Charger, On-Board 24v
7	56315270	1	Charger Cord, Us
8	56601417	1	Charger Mount Bracket
9	56478246	1	Cable Tie

NOTE 1: Standard on the following models: 56601008, 56601009, 56601010, 56601011, 56601012, 56601013, 56601019, 56601020

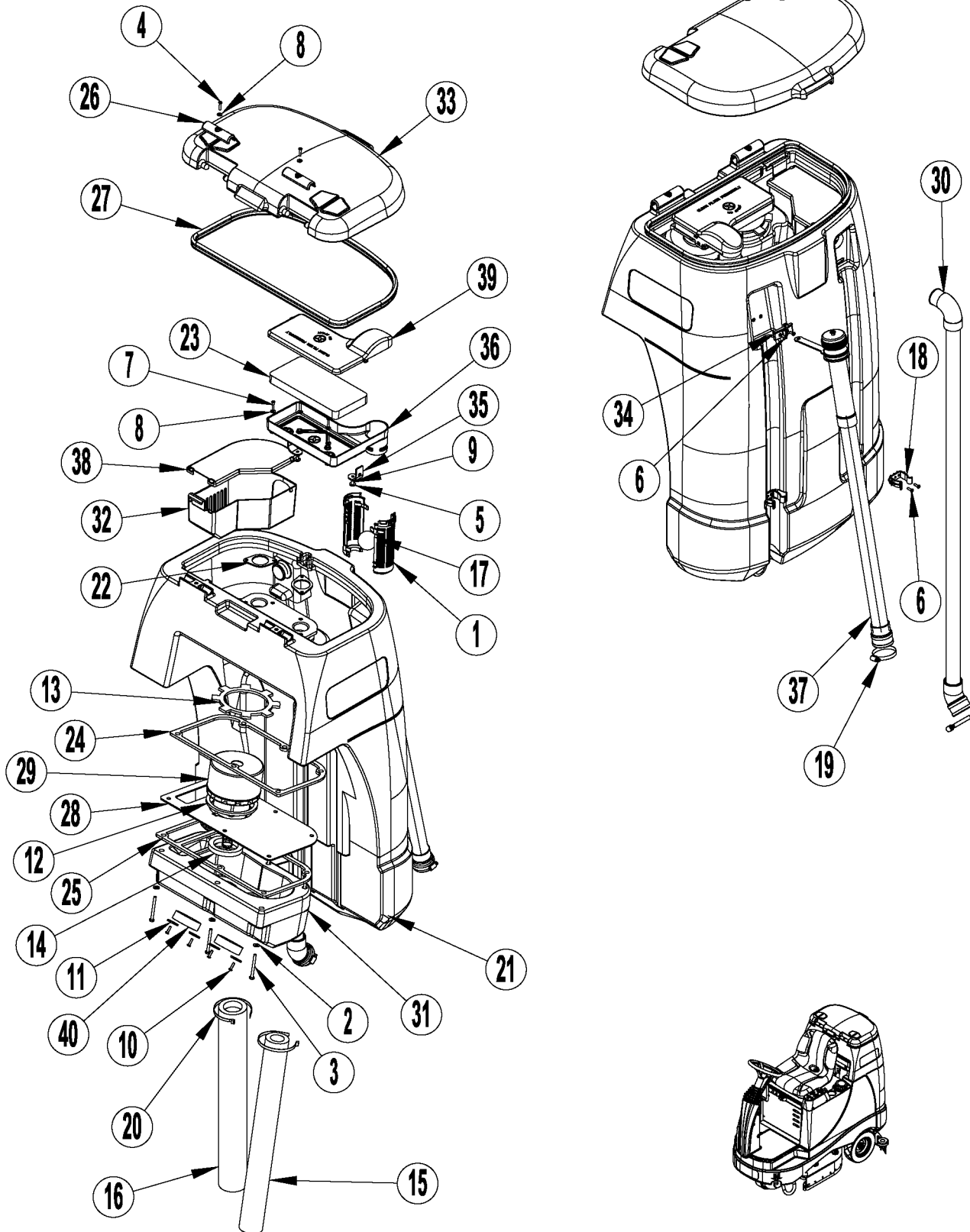

Item	Ref. No.	Qty	Description
1	56324497	2	Cage, Float
2	56002098	6	Wsh, Flt Sae 1/4
3	56002397	6	Scr, Hex 1/4-20 X 2.75
4	56002733	2	Scr, Pan Phil 10-24 X .88
5	56002859	2	Wsh, Flt Sae Ss 1/4
6	56002896	6	Scr, Pan Phil Ss 10-24 X .62
7	56002898	4	Scr, Pan Phil Ss 10-24 X 1.00
8	56002916	6	Wsh, Flt Sae Ss #10
9	56003799	2	Scr, Pan Phil Ss Plastite 1/4-10 X .50
10	56009005	4	Scr, Pan Phil Ss Type Ab 10-16 X .75 (STD/AXP)
11	56009199	4	Wsh, Flt Brass .266x1.250x.125 (STD/AXP)
12	56212143	1	Gasket, Vacuum Duct
13	56264103	1	Gasket, Vacuum Motor
14	56314760	1	Gasket, Vacuum Duct
15#	56315375	1	Foam, Acoustical
16	56315847	1	Foam Tube Assembly (STD/AXP)
17	56391690	1	Ball, Float
18	56407361	2	Clamp, Plastic
19	56440213	2	Clamp, Hose Sae #32
20#	56477613	2	Tie, Cable
21	56601120	1	Tank, Recovery
22	56601121	2	Gasket, Vac Filter
23	56601125	1	Filter
24	56601126	1	Gasket, Exhaust
25	56601127	1	Gasket, Vac
26	56601128	2	Hinge Clamp
27	56601130	1	Gasket, Recovery Lid
28	56601131	1	Vac Plate, Standard
29	56601132	1	Motor, Vac 24vdc (M5)
[]#	56397098	1	Carbon Brush (set of 2)
30	56601136	1	Recovery Hose
31	56601137	1	Cover, Vac Motor
32	56601138	1	Strainer Basket (STD/AXP)
33	56601139	1	Recovery Lid
34	56601204	1	Hook, Drain Hose
35	56601250	2	Strap, Filter Cover
36	56601253	1	Filter Box
37	56601404	1	Drain Hose
38	56601421	1	Cover, Debris (STD/AXP)
39	56601451	1	Cover, Fltr Box W/Gskt
40	9096672000	2	Filter (STD/AXP)

[] = Not Shown

= Revised or new since last update

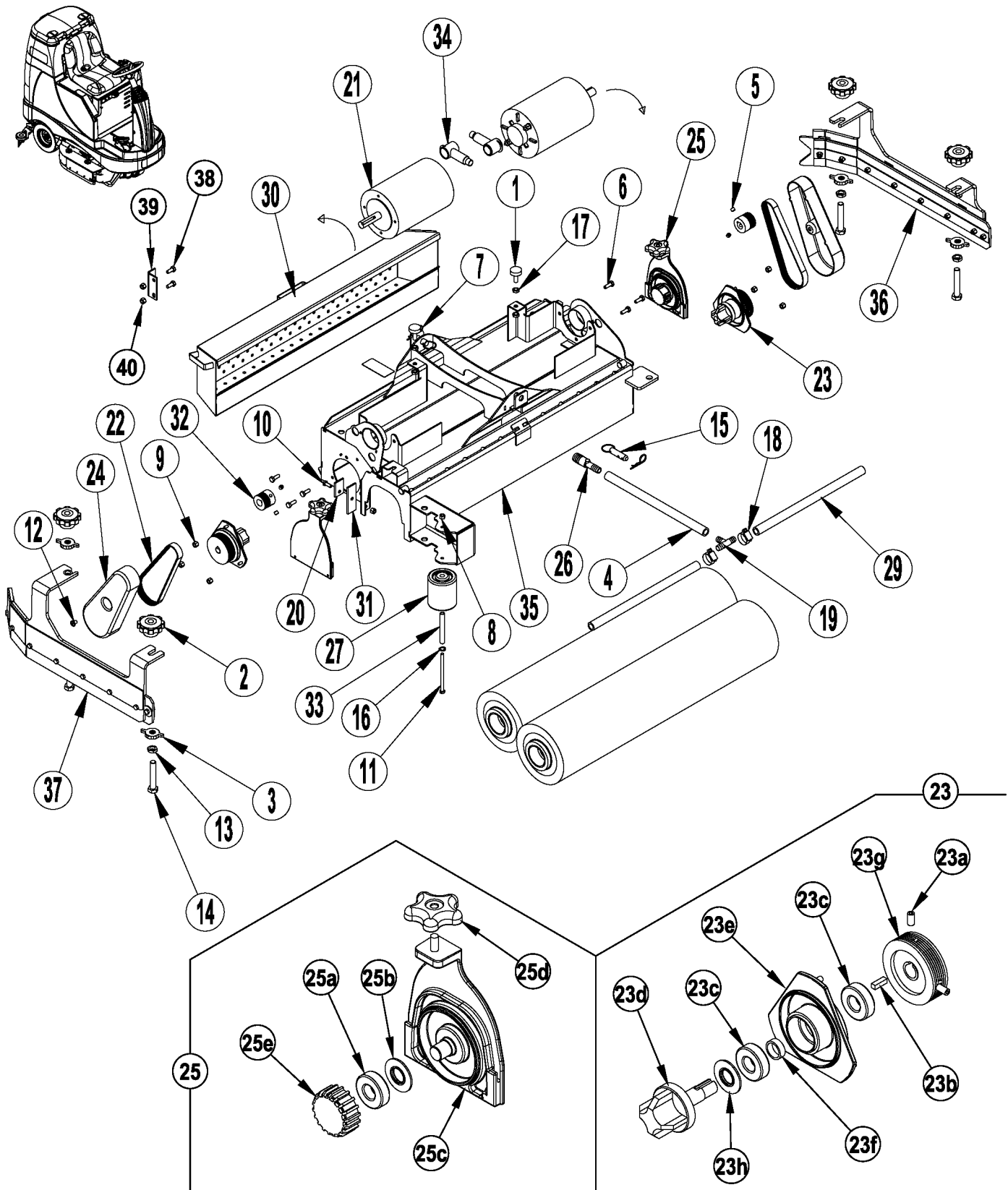

Item	Ref. No.	Qty	Description	Item	Ref. No.	Qty	Description
1	56401783	2	Leveler	23a	56002119	2	Scr, Soc Set Loc 1/4-20 x .50
2	56407114	4	Knob	23b	56003237	1	Key, Sq .19 x .62
3	56407334	4	Knob	23c	56106070	2	Bearing, Ball
4	56409462	1	Hose, Spiral	23d	56109527	1	Spindle
5	56002086	4	Scr, Soc Set Loc 5/16-18 X .25	23e	56315405	1	Bearing, Plate
6	56002948	6	Scr,Hex Hd Loc 1/4-20x.75	23f	56407389	1	Spacer
7	56002959	2	Pin, Cotter Hair	23g	56407442	1	Sheave, Poly-V
8	56003403	1	Nut, Hex Nyl Loc M6-1	23g	56407558	1	Washer, Bearing
9	56003426	8	Nut, Hex Nyl Loc Ss M6-1	24	56315445	2	Cover, Belt
10	56003431	2	Scr, Hex Ss M6-1 X 16mm	25	56315448	2	Idler End Assy
11	56003492	1	Scr, Hex M6-1 X 95mm	25a	56106070	1	Bearing, Ball
12	56003603	2	Scr, Pan Phil Thd Form 1/4-20 X .38	25b	56407558	1	Washer, Bearing
13	56003657	4	Nut, Hex Jam Ss M12-1.75	25c	56315447	1	Idler Beraing Plate
14	56003658	4	Scr, Hex Thd To Hd Ss M12-1.75 X 70mm	25d	56396254	1	Knob
15	56003671	2	Pin, Ring .50 X 1.25	25e	56407551	1	Hub
16	56009045	2	Wsh, Bowed .375x.578x.060	26	56315625	1	Barb, Coupler 1/2 X 3/4
17	56009086	4	Nut, Hex Jam 5/16-18	27	56316089	1	Wheel
18	56112771	2	Clamp, Hose Sae #10	28	56316210	2	Harness,Brush Motor (Not Shown)
19	56262549	1	Tee,Barb	29	56316553	2	Manifold, Pvc 28 Adv
20	56314436	2	Strap	30#	56601688	1	Hopper Weld't
21	56315061	2	Motor, 24 Vdc, .5 Hp, 1800 Rpm (M7 / M8)	31	56407391	2	Blade
[]	56407492	1	Brush Cap Assy	32	56407433	2	Sheave, Poly-V
[]	56407493	4	Brush Assy	33	56412176	1	Bushing
[]	56407494	4	Brush Cover Cap	34	56493357	2	Insulator, Terminal
22	56315321	2	Belt, Auto Tension	35	56601107	1	Housing Weld't
23	56315408	2	Drive End Assy	36	56601468	1	Left Skirt Assy
				37	56601476	1	Right Skirt Assy
				38#	56002667	2	Scr-Hex 5/16-18 x .75
				39#	56601675	1	Bracket
				40#	56002701	2	Nut-Hex Nyl Loc 5/16-18

[] = Not Shown

= Revised or new since last update

56601468 - Left Skirt Assy

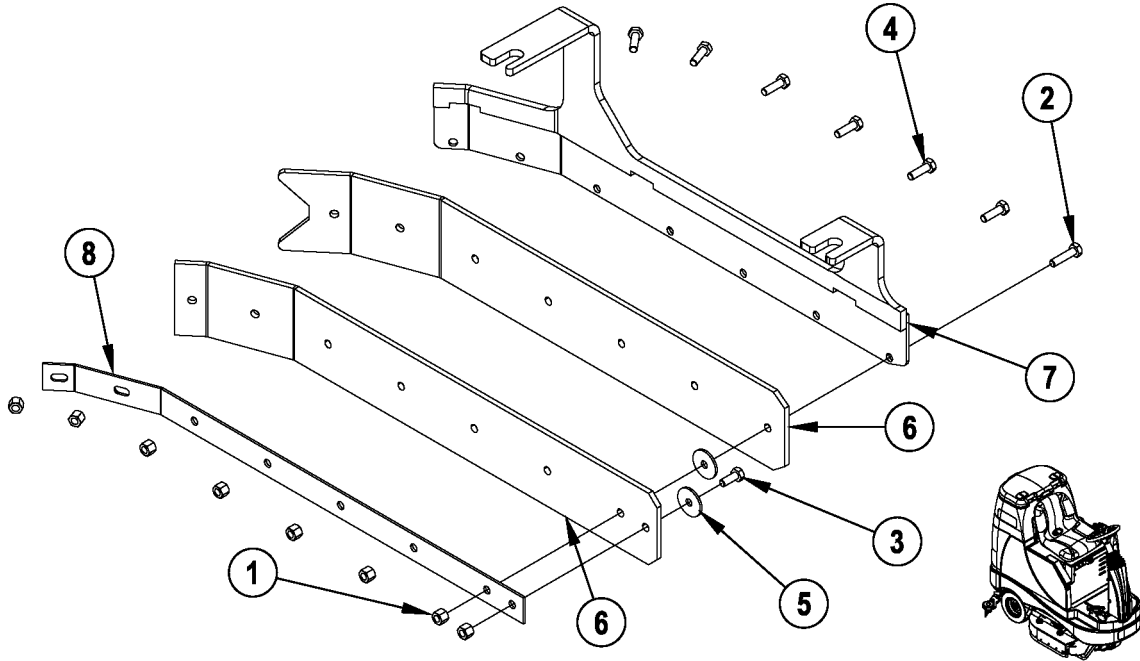

56601476 - Right Skirt Assy

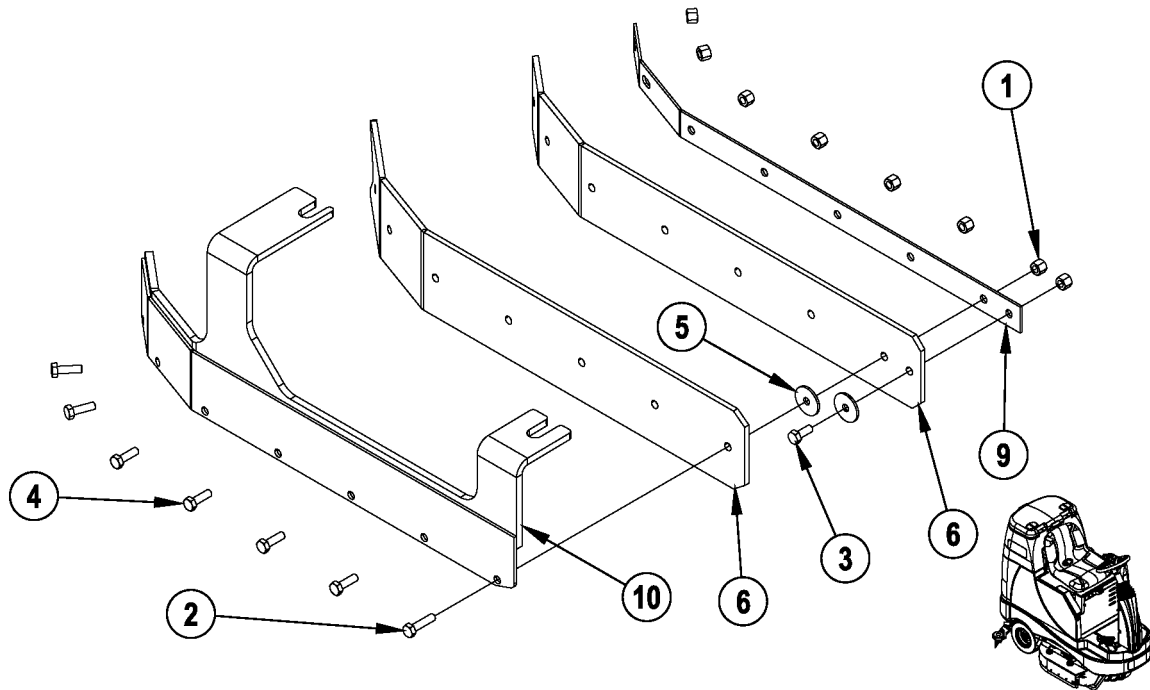

Item	Ref. No.	Qty	Description
	56601468	1	Left Skirt Assy (1-8)
	56601476	1	Right Skirt Assy (1-6, 9, 10)
1	56003426	8	Nut, Hex Nyl Loc SS M6-1
2	56003430	1	Scr, Hex SS M6-1 X 25mm
3	56003431	1	Scr, Hex SS M6-1 X 16mm
4	56003454	6	Scr, Hex Thd To Hd Ss M6-1 X 20mm
5	56009060	2	Wsh, Flt SS .260 X 1.000 X .074
6#	56316194	1	Blade Kit-Gum NOTE 2
*	56601538	1	Blade Kit-PU Cyl NOTE 2
*#	56601681	1	Blade Kit-Red Gum NOTE 2
7	56601464	1	Skirt Bracket Weld't (Left)
8	56601467	1	Retainer, Skirt (Left)
9#	56601690	1	Retainer, Skirt (Right)
10	56601477	1	Skirt Bracket Weld't (Right)

* = Optional, Not Included

= Revised or new since last update

NOTE 1: Quantities shown for items 1-7 are for one skirt assembly. There are two skirt assemblies on the machine.

NOTE 2: All deck blade kits include all blades necessary.

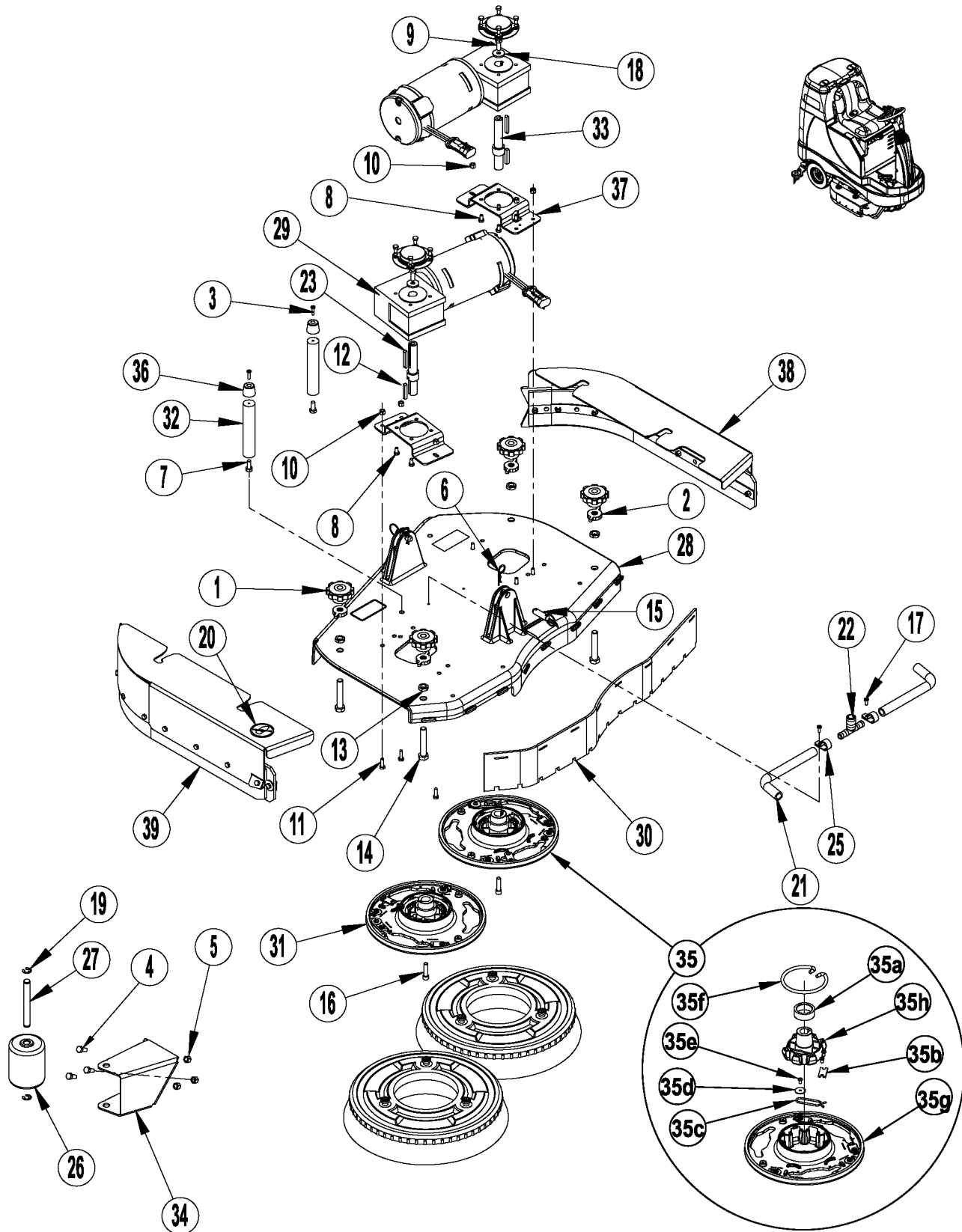

Item	Ref. No.	Qty	Description	Item	Ref. No.	Qty	Description
1	56407114	4	Knob	29	56601134	2	Motor Gearbox Assy (M7 / M8)
2#	56407334	4	Knob	[]	56601533	1	Gearbox
3	56002192	2	Scr, Pan Phil 10-24 X .75	[]	56314580	1	Bearing (fan end)
4	56002667	3	Scr, Hex 5/16-18 X .75	[]	56601537	1	Bearing (brush end)
5	56002701	3	Nut, Hex Nyl Loc 5/16-18	[]	56601534	2	Carbon Brush
6	56002959	2	Pin, Cotter Hair	[]	56601535	1	Key-6mm Square
7	56003012	2	Scr, Hex Ss 5/16-18 X .75	[]	56601508	1	Brush Motor Cover
8	56003211	8	Scr, Hex Ss M6-1 X 12mm	[]	56601536	1	Motor Fan
9	56003335	2	Scr, Hex Loc Ss 5/16-18 X .88	30#	56601248	1	Blade-Front Gum NOTE 2
10	56003426	6	Nut, Hex Nyl Loc Ss M6-1	*#	56601521	1	Blade-Front PU NOTE 2
11	56003454	6	Scr, Hex Thd To Hd Ss M6-1 X 20mm	31	56601276	1	Brush Plate Assy NOTE 1
12	56003526	2	Key, Square .25 X 1.44	32	56601289	2	Rod, Up Stop
13	56003657	4	Nut, Hex Jam Ss M12-1.75	33	56601319	2	Shaft, Hub Mount
14	56003658	4	Scr, Hex Thd To Hd Ss M12-1.75 X 70mm	34	56601364	1	Roller Brkt 28
15	56003786	2	Pin, Ring .500 X 1.18	35	56601384	1	Brush Plate Assy
16	56003798	2	Scr, Soc Hd 5/16-18 X 1.25 Zinc Plated	35a	61658a	1	Collar, Brush Driver
17	56009029	2	Scr, Pan Phil Thd Form 10-24 X .50	35b	56366455	1	Plate, Stop
18	56009057	2	Wsh, Flt Harden .344x1.000x.120/.135	35c	56366463	1	Spring Retainer
19	56003264	2	Ring-Ret Ext Type E .50 Dia	35d#	56009002	1	Wsh, Fit .266 X .906 X .060
20	56016163	1	Decal, No Step	35e	56009247	3	Scr, Pan Phil Plastite 10-14 X .38
21	56266108	2	Hose, Spiral .500	35f	56601056	1	Spring, Brush Holder
22	56305760	1	Tee, Barb 3/4 X 1/2 X 1/2	35g	56601118	1	Brush Plate
23	56314359	2	Key, 6mm Sq	35h	56601520	1	Gimbal, Motor
25	56328064	2	Clamp,P	36	56601388	2	Up Stop Mount
26	56407006	1	Wheel, Roller	37	56601389	2	Bracket, Motor
27	56601580	1	Pin	38	56601541	1	Skirt Assembly Lt 28
28	56601113	1	Scrub Deck, Cast	39	56601543	1	Skirt, Assy Rt
				[]#	56477613	1	Tie-Cable

* = Optional, Not Included

[] = Not Shown

= Revised or new since last update

NOTE 1: Item 31 (56601276) consists of the exact same components as item 35 (56601384).**NOTE 2:** All disk deck blade kits include all side skirt blades.

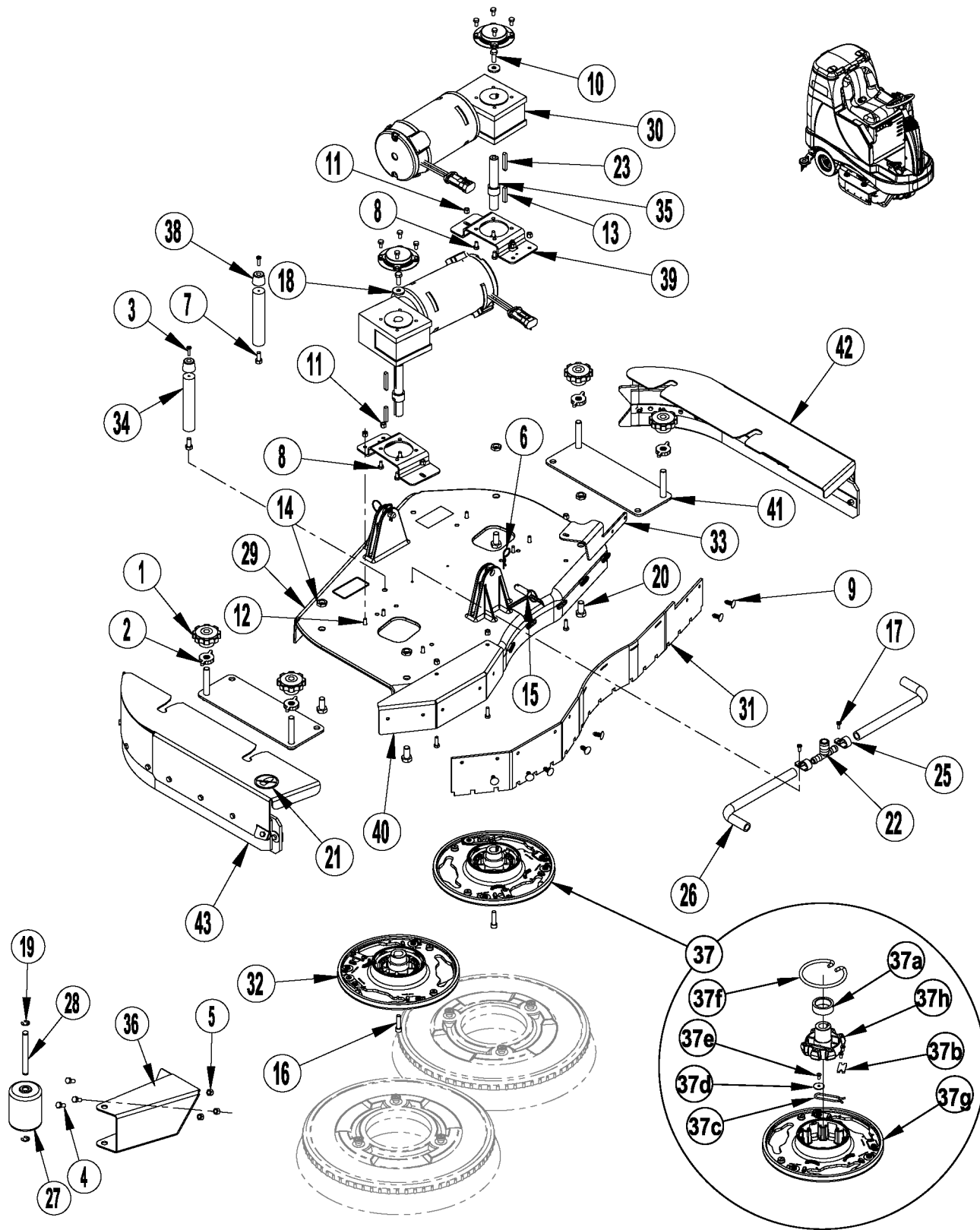

Item	Ref. No.	Qty	Description	Item	Ref. No.	Qty	Description
1	56407114	4	Knob	30	56601134	2	Motor Gearbox Assy (M7 / M8)
2#	56407334	4	Knob	[]	56601533	1	Gearbox
3	56002192	2	Scr, Pan Phil 10-24 X .75	[]	56314580	1	Bearing (fan end)
4	56002667	3	Scr, Hex 5/16-18 X .75	[]	56601537	1	Bearing (brush end)
5	56002701	3	Nut, Hex Nyl Loc 5/16-18	[]	56601534	2	Carbon Brush
6	56002959	2	Pin, Cotter Hair	[]	56601535	1	Key-6mm Square
7	56003012	2	Scr, Hex Ss 5/16-18 X .75	[]	56601508	1	Brush Motor Cover
8	56003211	8	Scr, Hex Ss M6-1 X 12mm	[]	56601536	1	Motor Fan
9	56003263	7	Rivet, Nylon Tree Push-In (.25)	31#	56601275	1	Blade-Front Gum NOTE 2
10	56003335	2	Scr, Hex Loc Ss 5/16-18 X .88	*#	56601522	1	Blade-Front PU NOTE 2
11	56003426	9	Nut, Hex Nyl Loc Ss M6-1	32	56601276	1	Brush Plate Assy NOTE 1
12	56003454	9	Scr, Hex Thd To Hd Ss M6-1 X 20mm	33	56601278	1	Skirt Bracket, Front 34
13	56003526	2	Key, Square .25 X 1.44	34	56601289	2	Rod, Up Stop
14	56003657	4	Nut, Hex Jam Ss M12-1.75	35	56601319	2	Shaft, Hub Mount
15	56003786	2	Pin, Ring .500 X 1.18	36	56601365	1	Roller Brkt 34
16	56003798	2	Scr, Soc Hd 5/16-18 X 1.25 Zinc Plated	37	56601384	1	Brush Plate Assy
17	56009029	2	Scr, Pan Phil Thd Form 10-24 X .50	37a	61658a	1	Collar, Brush Driver
18	56009057	2	Wsh, Flt Harden .344x1.000x.120/.135	37b	56366455	1	Plate, Stop
19	56003264	2	Ring-Ret Ext Type E .50 Dia	37c	56366463	1	Spring Retainer
20	56009119	4	Scr, Hex Thd To Hd M12-1.75 X 25mm	37d#	56009002	1	Wsh, Flt .266 X .906 X .060
21	56016163	1	Decal, No Step	37e	56009247	3	Scr, Pan Phil Plastite 10-14 X .38
22	56305760	1	Tee, Barb 3/4 X 1/2 X 1/2	37f	56601056	1	Spring, Brush Holder
23	56314359	2	Key, 6mm Sq	37g	56601118	1	Brush Plate
25	56328064	2	Clamp,P	37h	56601520	1	Gimbal, Motor
26	56387302	2	Hose, Spiral .500	38	56601388	2	Up Stop Mount
27	56407006	1	Wheel, Roller	39	56601389	2	Bracket, Motor
28	56601580	1	Pin	40	56601452	1	Brush Cover
29	56601113	1	Scrub Deck, Cast	41	56601502	2	Side Skirt Weldment
				42	56601542	1	Skirt Assembly Lt 34
				43	56601543	1	Skirt, Assy Rt
				[]#	56477613	1	Tie-Cable

* = Optional, Not Included

[] = Not Shown

= Revised or new since last update

NOTE 1: Item 32 (56601276) consists of the exact same components as item 37 (56601384).**NOTE 2:** All disk deck blade kits include all side skirt blades.

56601541 (28") / 56601542 (34") - Left Skirt Assy

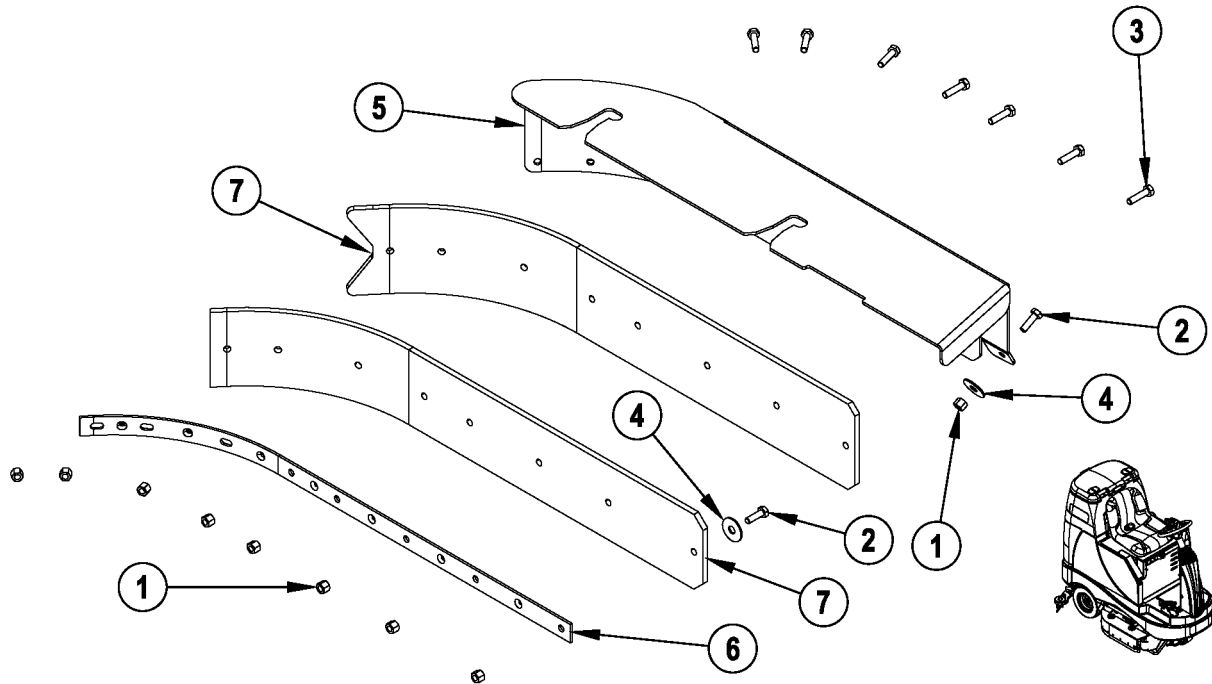

56601543 - Right Skirt Assy

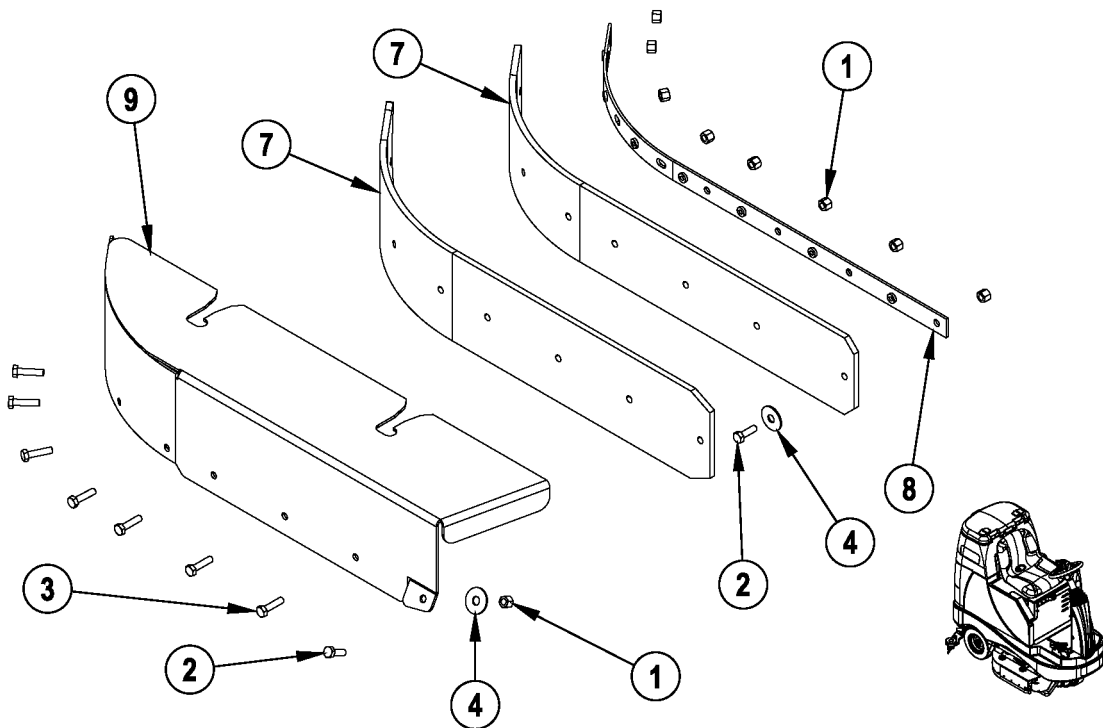

Item	Ref. No.	Qty	Description
	56601541	1	Left Skirt Assy (28" / 1-8)
	56601542	1	Left Skirt Assy (34" / 1-8)
	56601543	1	Right Skirt Assy (All Models / 1-4, 7, 8, 9, 10)
1	56003426	9	Nut, Hex Nyl Loc Ss M6-1
2	56003454	2	Scr, Hex Thd To Hd Ss M6-1 X 20mm
3	56003695	7	Scr, Hex Thd To Hd Ss M6-1 X 25mm
4	56003696	2	Wsh, Flt Ss .33 X 1.00 X.060
5	56601327	1	Frame, Skirt Lh 34 (34" / Left)
[]	56601279	1	Frame, Skirt Lh 28 (28" / Left)
6	56601337	1	Retainer, Skirt (34" / Left)
[]	56601315	1	Retainer, Skirt (28" / Left)
7#	56601092	1	Blade Kit-Gum NOTE 2
*#	56601091	1	Blade Kit-PU NOTE 2
*#	56601678	1	Blade Kit-Red Gum NOTE 2
8	56601315	1	Retainer, Skirt (All Models / Right)
9	56601157	1	Frame, Skirt Rh (All Models / Right)

* = Optional, Not Included

[] = Not Shown

= Revised or new since last update

NOTE 1: Quantities shown for items 1-4 and 7-8 are for one skirt assembly. There are two skirt assemblies on the machine.

NOTE 2: All disk deck blade kits include all side skirt blades.

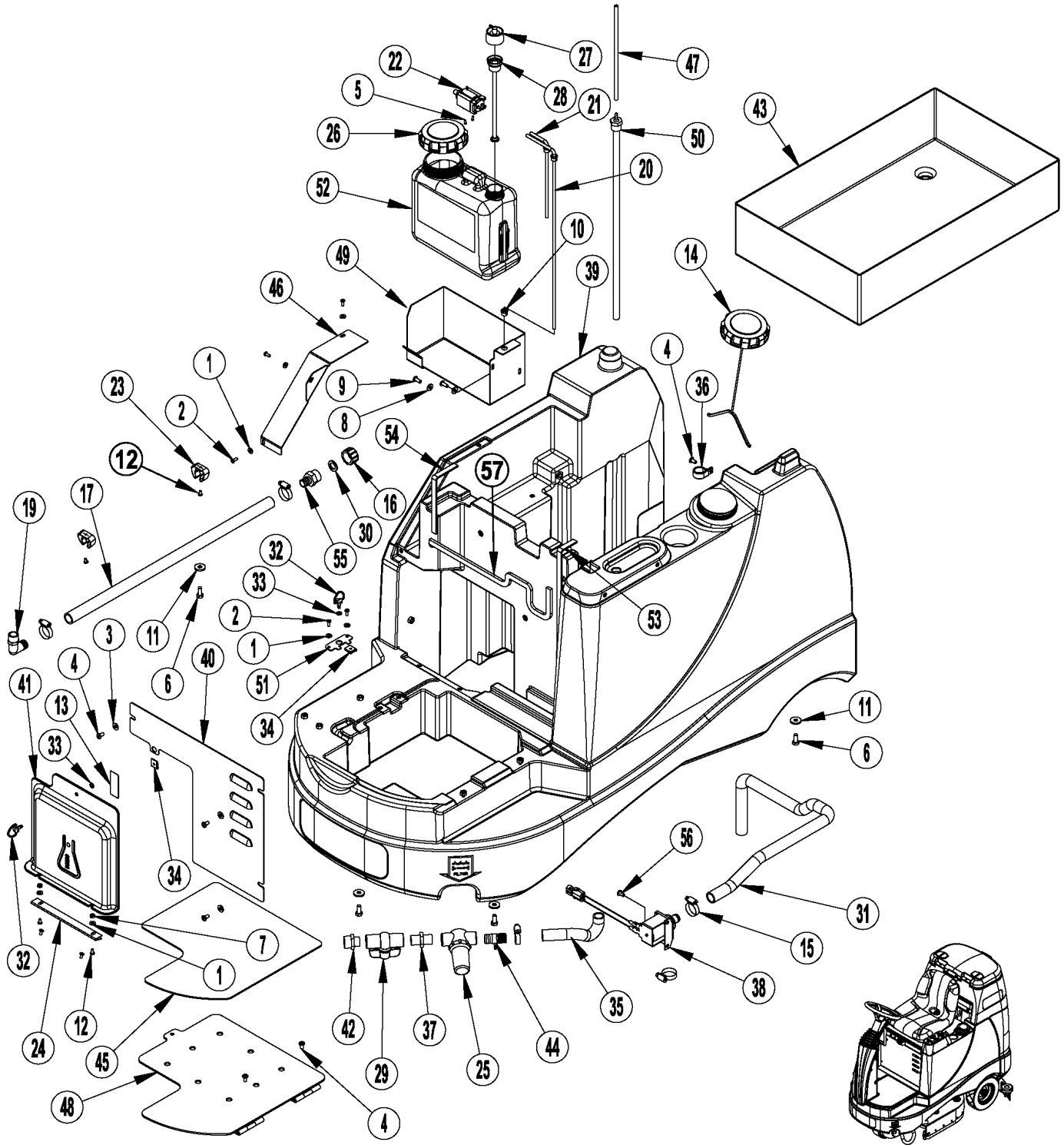

Item	Ref. No.	Qty	Description
1	56001954	7	Wsh, Flt Sae #10
2	56001993	5	Scr, Pan Phil 10-24 X .50
3	56002098	3	Wsh, Flt Sae 1/4
4	56002145	8	Scr, Pan Phil 1/4-20 X .50
5	56002539	2	Scr, Pan Phil Thd Form 6-32 X .31
6	56002667	4	Scr, Hex 5/16-18 X .75
7	56002832	2	Nut, Hex Nyl Loc-Thin 10-24
8	56002859	2	Wsh, Flt Sae Ss 1/4
9	56002989	2	Scr, Pan Phil Ss 1/4-20 X .62
10	56003699	3	Bushing, 1/4 Id Snub
11	56009122	4	Wsh, Flt .344 X .938 X .125
12	56009139	6	Scr, Pan Phil Loc 10-24 X .38
13	56016331	1	Decal, Chemical Ratio
14	56601599	1	Cap, Raw W/ Tether
15	56244969	5	Clamp, Hose Sae #12
16	56255076	1	Cap, Pipe Ght Nylon
17	56261265	1	Hose, .75 Clear Pvc, 25.00
18#			DELETED
19	56314757	1	Barb, 90 Elbow 3/4 X 1/2npt
20	56314942	1	Hose, Chem Resistant
21	56314991	1	Hose, Chem Resistant 14"
22	56315241	1	Pump, Chemical (M2)
23	56601598	2	Hose Clip
24	56315285	1	Hinge
25	56315296	1	Solution Filter
*	56601594	A/R	Solution Filter Kit
26	56315517	1	Cap, Raw
27	56315523	1	Cap, Dry Break, 1/8 Barb, 90°
28	56315527	1	Insert, Dry Break
29	56315607	1	Ball Valve
30	56368776	1	Washer, Rubber
31	56379139	1	Hose
32	56380132	2	Latch, 1/4 Turn
33	56380137	2	Retainer
34	56380141	2	Nut, Clamp
35	30445A	1	Hose-Solution
36	56410097	3	Clamp, P
37	56412182	1	Nipple, Hex 3/4-14
38	56601064	1	Solenoid Valve Assy (L1)
39	56601076	1	Solution Tank
40	56601106	1	Panel
41	56601202	1	Chemical Bottle Cover
42	56601212	1	Nipple, Reducer 3/4"Npt X 1/2"Npt
43	56601213	1	Battery Box
44	56601236	1	Tee, Special, 3/4 X 3/16 X 1/2npt
45	56601246	1	Mat
46	56601268	1	Plate
47	56601273	1	Hose
48	56601339	1	Charger Cover Weldment
49	56601398	1	Bracket
50	56601481	1	Tube, Pressure Sensing
51	56601511	1	Plate
52	56601544	1	Chemical Bottle Assy
*	56601545	A/R	Chemical Bottle Assy (26, 28 & 52)
53	56601569	1	Gasket
54	56601570	1	Gasket
55	56900273	1	Barb, Adapter 3/4 X 3/4ght
56	56003039	1	Scr, Hex Hd Loc 1/4-20 x .50
57#	56601685	1	Gasket

* = Optional, Not Included

= Revised or new since last update

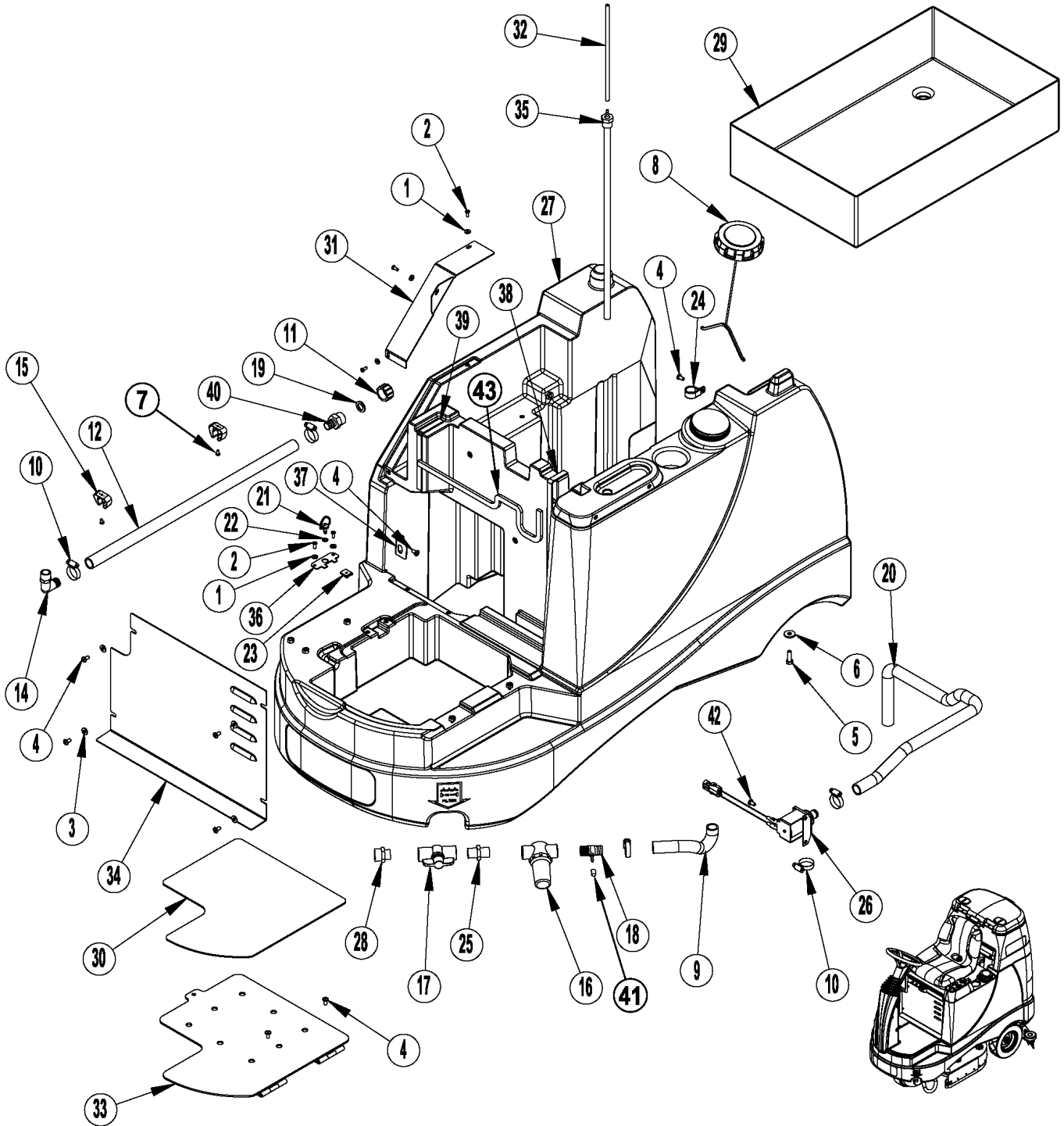

Item	Ref. No.	Qty	Description
1	56001954	5	Wsh, Flt Sae #10
2	56001993	5	Scr, Pan Phil 10-24 X .50
3	56002098	4	Wsh, Flt Sae 1/4
4	56002145	10	Scr, Pan Phil 1/4-20 X .50
5	56002667	4	Scr, Hex 5/16-18 X .75
6	56009122	4	Wsh, Flt .344 X .938 X .125
7	56009139	2	Scr, Pan Phil Loc 10-24 x .38
8	56601599	1	Cap, Raw W/ Tether
9	30445A	1	Hose, Solution
10	56244969	5	Clamp, Hose Sae #12
11	56255076	1	Cap, Pipe Ght Nylon
12	56261265	1	Hose, .75 Clear Pvc, 25.00
13#			DELETED
14	56314757	1	Barb, 90 Elbow 3/4 X 1/2npt
15	56601598	2	Hose Clip
16	56315296	1	Solution Filter
*	56601594	A/R	Solution Filter Kit
17	56315607	1	Ball Valve
18	56601236	1	Barb, Adaptor 3/4 X 1/2 Npt
19	56368776	1	Washer, Rubber
20	56379139	1	Hose
21	56380132	1	Latch, 1/4 Turn
22	56380137	1	Retainer
23	56380141	1	Nut, Clamp
24	56410097	3	Clamp, P
25	56412182	1	Nipple, Hex 3/4-14
26	56601064	1	Solenoid Valve Assy (L1)
27	56601076	1	Solution Tank
28	56601212	1	Nipple, Reducer 3/4"Npt X 1/2"Npt
29	56601213	1	Battery Box
30	56601246	1	Mat
31	56601268	1	Plate
32	56601273	1	Hose
33	56601339	1	Charger Cover Weldment
34	56601387	1	Electrical Cover Panel
35	56601481	1	Tube, Pressure Sensing
36	56601511	1	Plate
37	56601670	1	Bracket, L
38	56601569	1	Gasket
39	56601570	1	Gasket
40	56900273	1	Barb, Adapter 3/4 X 3/4ght
41	56051209	1	Rubber Tip-Black
42	56003039	1	Scr, Hex Hd Loc 1/4-20 x .50
43#	56601685	1	Gasket

* = Optional, Not Included

= Revised or new since last update

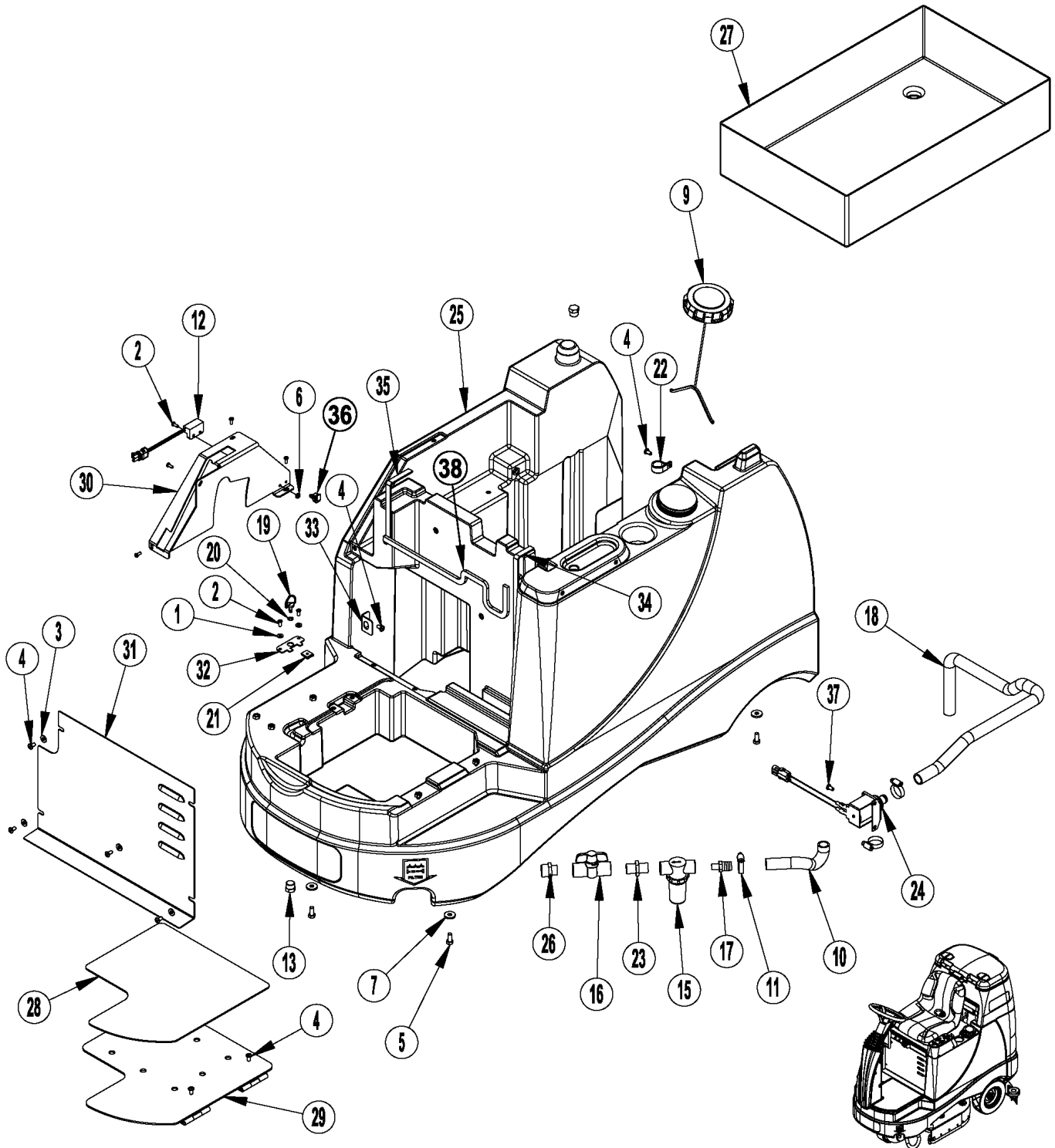

Item	Ref. No.	Qty	Description
1#	56001954	6	Wsh, Flt Sae #10
2	56001993	7	Scr, Pan Phil 10-24 X .50
3	56002098	4	Wsh, Flt Sae 1/4
4	56002145	10	Scr, Pan Phil 1/4-20 X .50
5	56002667	4	Scr, Hex 5/16-18 X .75
6	56002832	1	Nut, Hex Nyl Loc-Thin 10-24
7	56009122	4	Wsh, Flt .344 X .938 X .125
9	56601599	1	Cap, Raw W/ Tether
10	30445A	1	Hose, Solution
11	56244969	3	Clamp, Hose Sae #12
12	56305053	1	Sensor, Proximity
13	56305547	2	Plug, 1/2 Hex Pipe
14#			DELETED
15	56315296	1	Solution Filter
*	56601594	A/R	Solution Filter Kit
16	56315607	1	Ball Valve
17	56315634	1	Barb, Adaptor 3/4 X 1/2 Npt
18	56379139	1	Hose
19	56380132	1	Latch, 1/4 Turn
20	56380137	1	Retainer
21	56380141	1	Nut, Clamp
22	56410097	3	Clamp, P
23	56412182	1	Nipple, Hex 3/4-14
24	56601064	1	Solenoid Valve Assy (L1)
25	56601076	1	Solution Tank
26	56601212	1	Nipple, Reducer 3/4"Npt X 1/2"Npt
27	56601213	1	Battery Box
28	56601246	1	Mat
29	56601339	1	Charger Cover Weldment
30	56601344	1	Cover, Handle
31	56601387	1	Electrical Cover Panel
32	56601511	1	Plate
33	56601670	1	Bracket, L
34	56601569	1	Gasket
35	56601570	1	Gasket
36	56507793	1	Clip-Conduit
37	56003039	1	Scr-Hex Hd Loc 1/4-20 x .50
38#	56601685	1	Gasket

* = Optional, Not Included

= Revised or new since last update

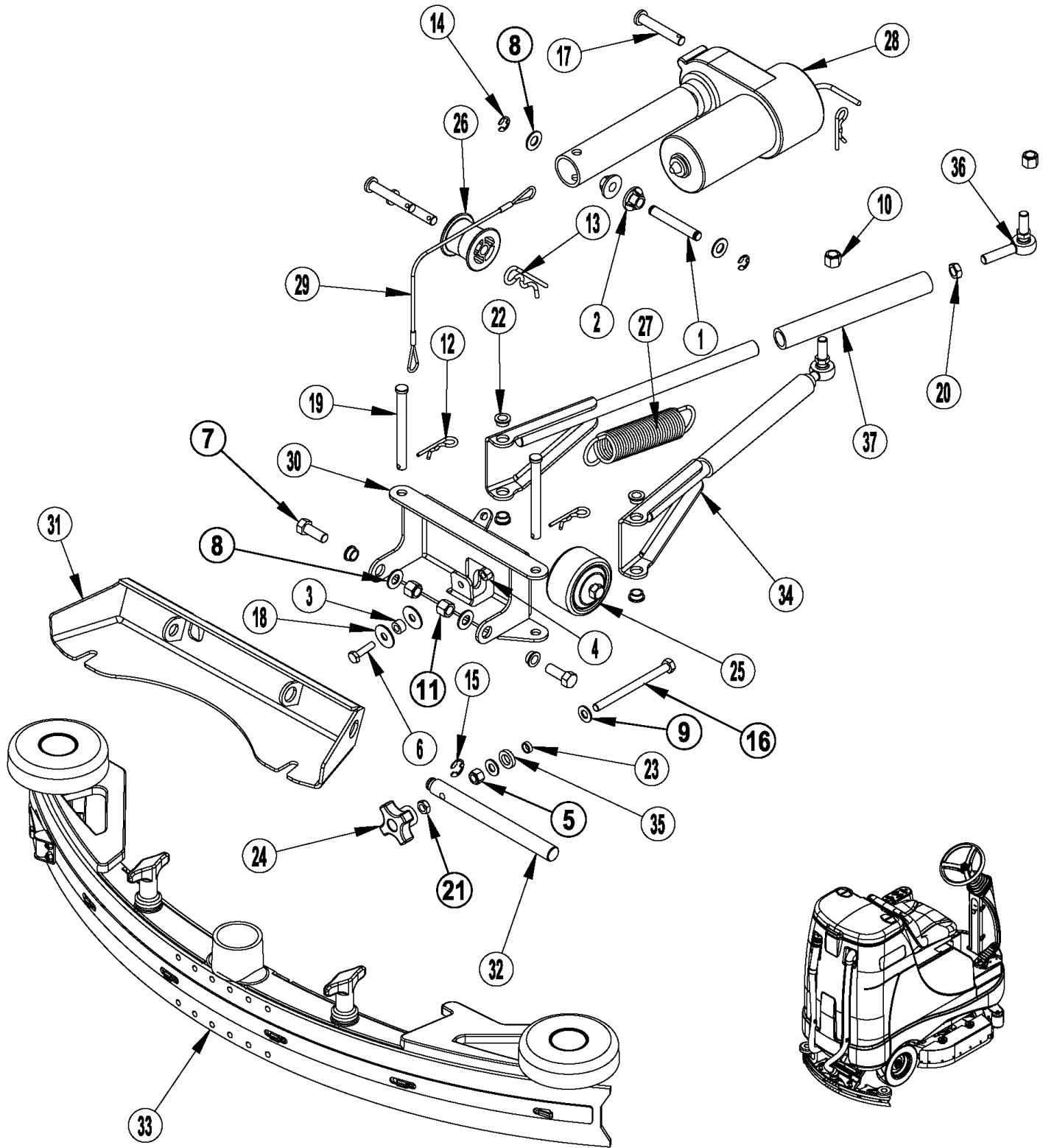

Item	Ref. No.	Qty	Description
1	56412088	1	Pin
2	56412248	2	Spacer, Squeegee Cable
3	56453691	1	Spacer
4	56002491	1	Nut, Hex Nyl Loc Ss 1/4-20
5	56002856	1	Nut, Hex Nyl Loc Ss 5/16-18
6	56002883	1	Scr, Hex Ss 1/4-20 X 1.00
7	56002886	2	Scr, Hex Ss 3/8-16 X 1.00
8	56002910	4	Wsh, Flt Sae Ss 3/8
9	56002938	2	Wsh, Flt Sae Ss 5/16
10	56002951	2	Nut, Hex Nyl Loc 3/8-24
11	56003219	2	Nut, Hex Nyl Loc Ss 3/8-16
12	56003222	3	Pin, Cotter Hair
13	56003223	1	Pin, Cot Hair .148 X Dia .62/1.00
14	56003262	2	Ring, Ret Ext Type E 0.38 Dia
15	56003264	1	Ring, Ret Ext Type E 0.50 Dia
16	56003486	1	Scr, Hex Thd To Hd Ss 5/16-18 X 4.00
17	56003656	3	Pin, Clevis .375 X 2.25
18	56003696	2	Wsh, Flt Ss .33 X 1.00 X.060
19	56003713	2	Pin, Clevis .38 X 3.75
20	56009103	2	Nut, Hex Jam 3/8-24
21	56009141	1	Nut, Hex Jam Ss 5/16-18
22	56324505	6	Bearing, Flange
23	56381818	1	Bushing .32x.44x.15
24	56407303	1	Knob
25	56412124	1	Wheel
26	56412208	1	Roller
27	56412216	1	Spring, Extension
28	56601147	1	Actuator, Motor 24v (M3)
29	56601257	1	Cable Assembly
30	56601436	1	Squeegee Pivot Bracket Weld't
31	56601438	1	Squeegee Mount Bracket Weld't
32	56601442	1	Shaft
33	56601449	1	Squeegee Assembly (28")
	56601454	1	Squeegee Assembly (34")
34	56601460	2	Bar Weldment
35	56601463	1	Washer, Polyurethane
36	56601469	2	Rod End
37	56601512	2	Hose

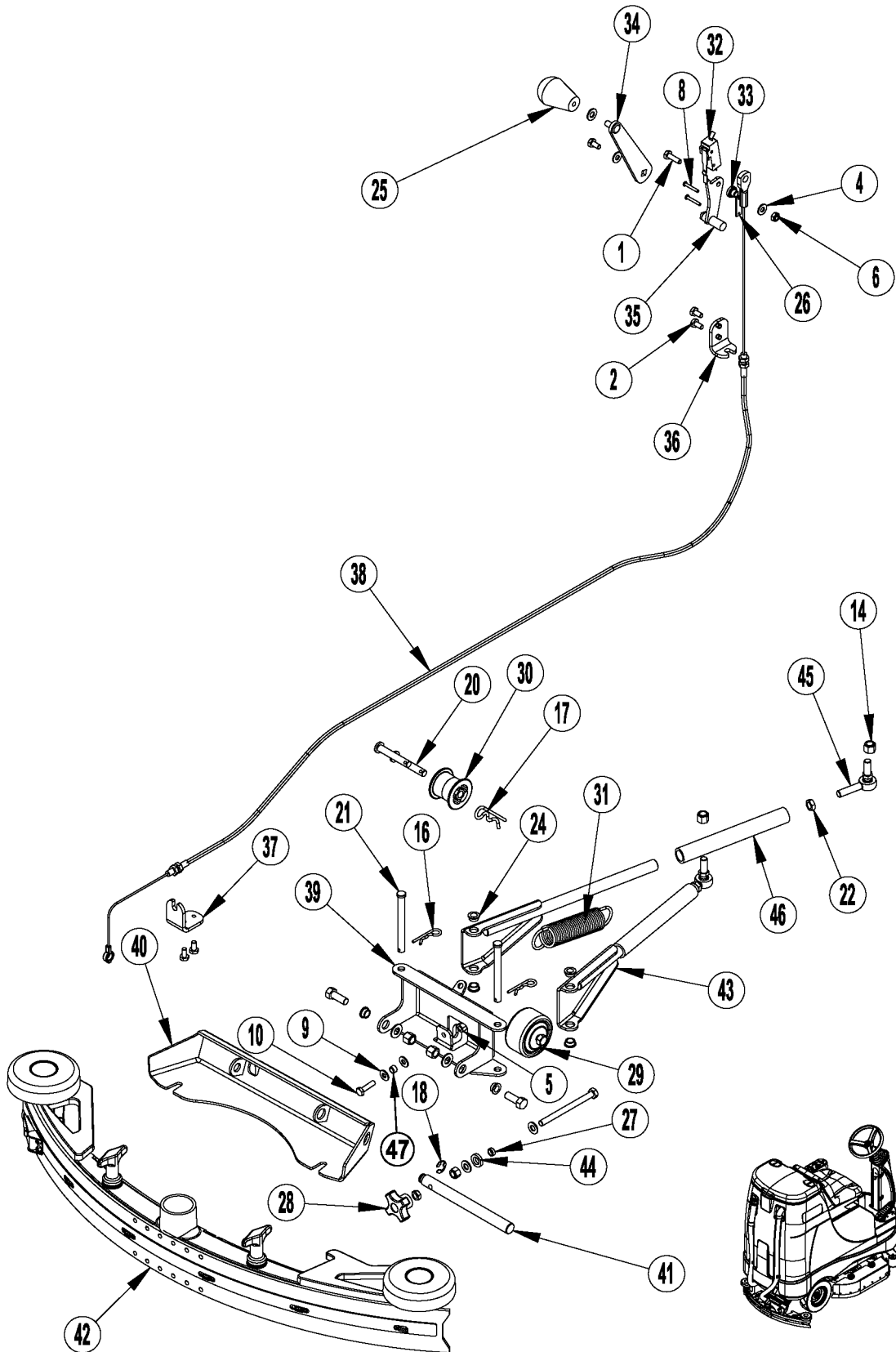

08-11

SQUEEGEE SYSTEM-ST

08-12

Advenger™**35**

Item	Ref. No.	Qty	Description
1	56001821	1	Scr, Hex 1/4-20 X .88
2	56001854	5	Scr, Hex 1/4-20 X .50
3	56001939	1	Wsh, Flt Sae 5/16
4	56002098	2	Wsh, Flt Sae 1/4
5	56002491	1	Nut, Hex Nyl Loc Ss 1/4-20
6	56002840	1	Nut, Hex Nyl Loc-Thin 1/4-20
7	56002856	1	Nut, Hex Nyl Loc Ss 5/16-18
8	56002858	2	Scr, Pan Phil 6-32 X 1.00
9	56002859	2	Wsh, Flt Sae Ss 1/4
10	56002883	1	Scr, Hex Ss 1/4-20 X 1.00
11	56002886	2	Scr, Hex Ss 3/8-16 X 1.00
12	56002910	2	Wsh, Flt Sae Ss 3/8
13	56002938	2	Wsh, Flt Sae Ss 5/16
14	56002951	2	Nut, Hex Nyl Loc 3/8-24
15	56003219	2	Nut, Hex Nyl Loc Ss 3/8-16
16	56003222	2	Pin, Cotter Hair
17	56003223	1	Pin, Cot Hair .148 X Dia .62/1.00
18	56003264	1	Ring, Ret Ext Type E 0.50 Dia
19	56003486	1	Scr, Hex Thd To Hd Ss 5/16-18 X 4.00
20	56003656	2	Pin, Clevis .375 X 2.25
21	56003713	2	Pin, Clevis .38 X 3.75
22	56009103	2	Nut, Hex Jam 3/8-24
23	56009141	1	Nut, Hex Jam Ss 5/16-18
24	56324505	6	Bearing, Flange
25	56364527	1	Knob
26	56376015	1	Nut Plate
27	56381818	1	Bushing .32x.44x.15
28	56407303	1	Knob
29	56412124	1	Wheel
30	56412208	1	Roller
31	56412216	1	Spring, Extension
32	56601160	1	Switch, Snap, Spst No
33	56601190	1	Bushing, Cable
34	56601218	1	Linkage Arm
35	56601221	1	Linkage, Weldment
36	56601233	1	Bracket, Cable
37	56601234	1	Bracket, Cable
38	56601235	1	Cable
39	56601436	1	Squeegee Pivot Bracket Weld't
40	56601438	1	Squeegee Mount Bracket Weld't
41	56601442	1	Shaft
42	56601449	1	Squeegee Assembly (28")
	56601454	1	Squeegee Assembly (34")
43	56601460	2	Bar Weldment
44	56601463	1	Washer, Polyurethane
45	56601469	2	Rod End
46	56601512	2	Hose
47	56453849	1	Bushing

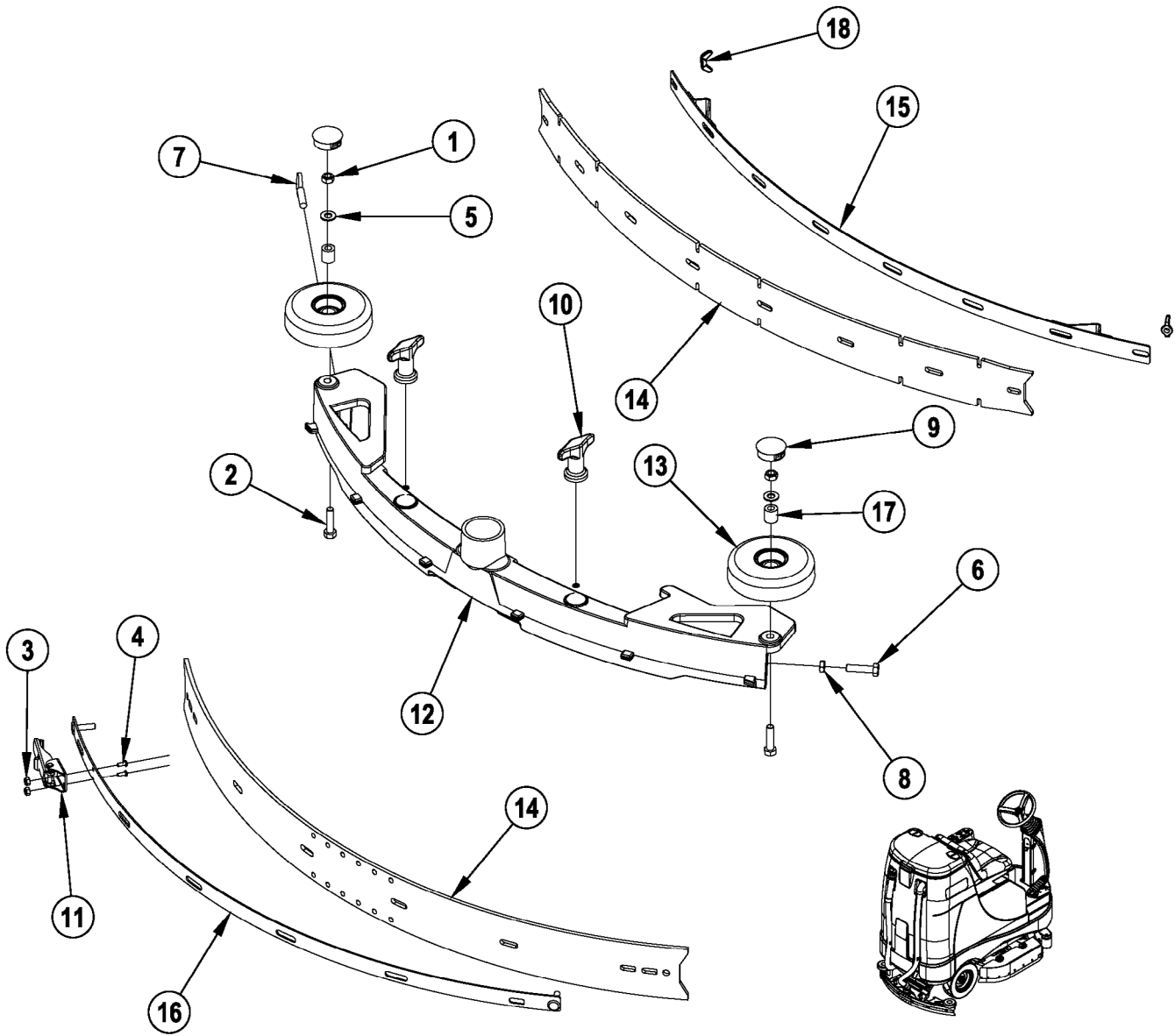

Item	Ref. No.	Qty	Description
	56601449	1	Squeegee Assembly (28")
	56601454	1	Squeegee Assembly (34")
1	56002851	2	Nut, Hex Nyl Loc-Thin Ss 5/16-18
2	56002884	2	Scr, Hex Ss 5/16-18 X 1.25
3	56002907	2	Nut, Hex Nyl Loc Ss 6-32
4	56002909	2	Scr, Pan Phil Ss 6-32 X .38
5	56002938	2	Wsh, Flt Sae Ss 5/16
6	56003302	1	Scr, Hex Thd To Hd Ss 5/16-18 X 1.25
7	56003792	1	Scr, Thumb Ss 5/16-18 X 1.25
8	56009141	1	Nut, Hex Jam Ss 5/16-18
9	56111444	2	Button Plug-1.25
10	56370711	2	Nut, Thumb
11	56471194	1	Do Not Use!
12	56601444	1	Squeegee Casting (28")
	56601455	1	Squeegee Casting (34")
13	56601450	2	Wheel, 4.00 Od
14#	56601531	1	Blade Kit-Squeegee-Standard (28") NOTE 1
*#	56601529	1	Blade Kit-Squeegee-Polyurethane (28") NOTE 1
*#	56601083	1	Blade Kit-Squeegee-Red Gum (28") NOTE 1
#	56601532	1	Blade Kit-Squeegee-Standard (34") NOTE 1
*#	56601530	1	Blade Kit-Squeegee-Polyurethane (34") NOTE 1
*#	56601094	1	Blade Kit-Squeegee-Red Gum (34") NOTE 1
15	56601489	1	Front Strap Weldment (28")
	56601495	1	Front Strap Weldment (34")
16	56601591	1	Strap, Rear (28")
	56601593	1	Strap, Rear (34")
17	56601499	2	Bushing, Nylon
18	56009111	2	Nut-Wing SS 1/4-20

* = Optional, Not Included

= Revised or new since last update

NOTE 1: All squeegee blade kits include both front and rear squeegee blades.

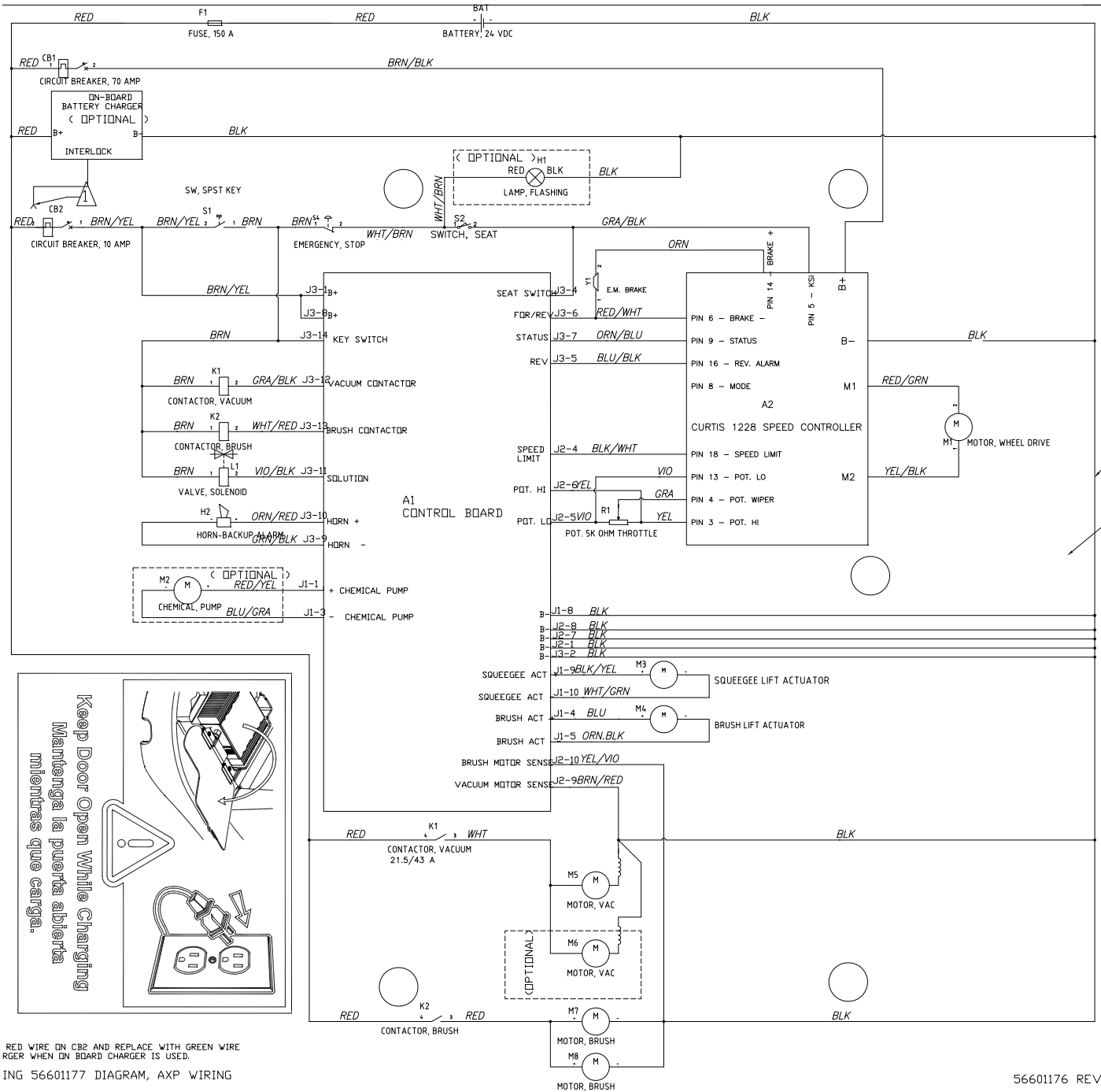

Item	Ref. No.	Qty	Description
A1	56601565	1	Control PCB Assy
A2	56601061	1	Controller, Speed
BAT	N/A		Battery
F1	56412089	1	Fuse, 150 Amp
CB1	56454429	1	Circuit Breaker, 70 Amp
CB2	56507644	1	Circuit Breaker, 10 Amp
H1	56307166	1	Beacon, Warning (optional)
H2	56412177	1	Horn/Backup Alarm
K1	56601183	1	Contactactor 24v, 100 Amp
K2	56412179	1	Contactactor 24v
L1	56601064	1	Solenoid Valve Assy
M1	56601050	1	Motor / Drive Wheel
M2	56315241	1	Pump, Chemical
M3	56601147	1	Actuator, Motor 24v
M4	56601432	1	Lift Actuator Assembly
M5	56601132	1	Motor, Vac 24vdc
M6	56601132	1	Motor, Vac 24vdc (optional)
M7	56315061	1	Motor, 24 Vdc, .5 Hp, 1800 Rpm (cylindrical)
	56601134	2	Motor Gearbox Assy (disk)
M8	56315061	1	Motor, 24 Vdc, .5 Hp, 1800 Rpm (cylindrical)
	56601134	2	Motor Gearbox Assy (disk)
R1	N/A	1	Part of 56601052
S1	56303553	1	Key Switch
*	56303526	A/R	Replacement Key Set
S2	7-82-00050	1	Switch, Seat
S4	56407130	1	Disconnect, Emergency
Y1	56601507	1	Brake, Electromagnetic
	56315124	1	Charger, On-Board 24v TSBUS2008-984

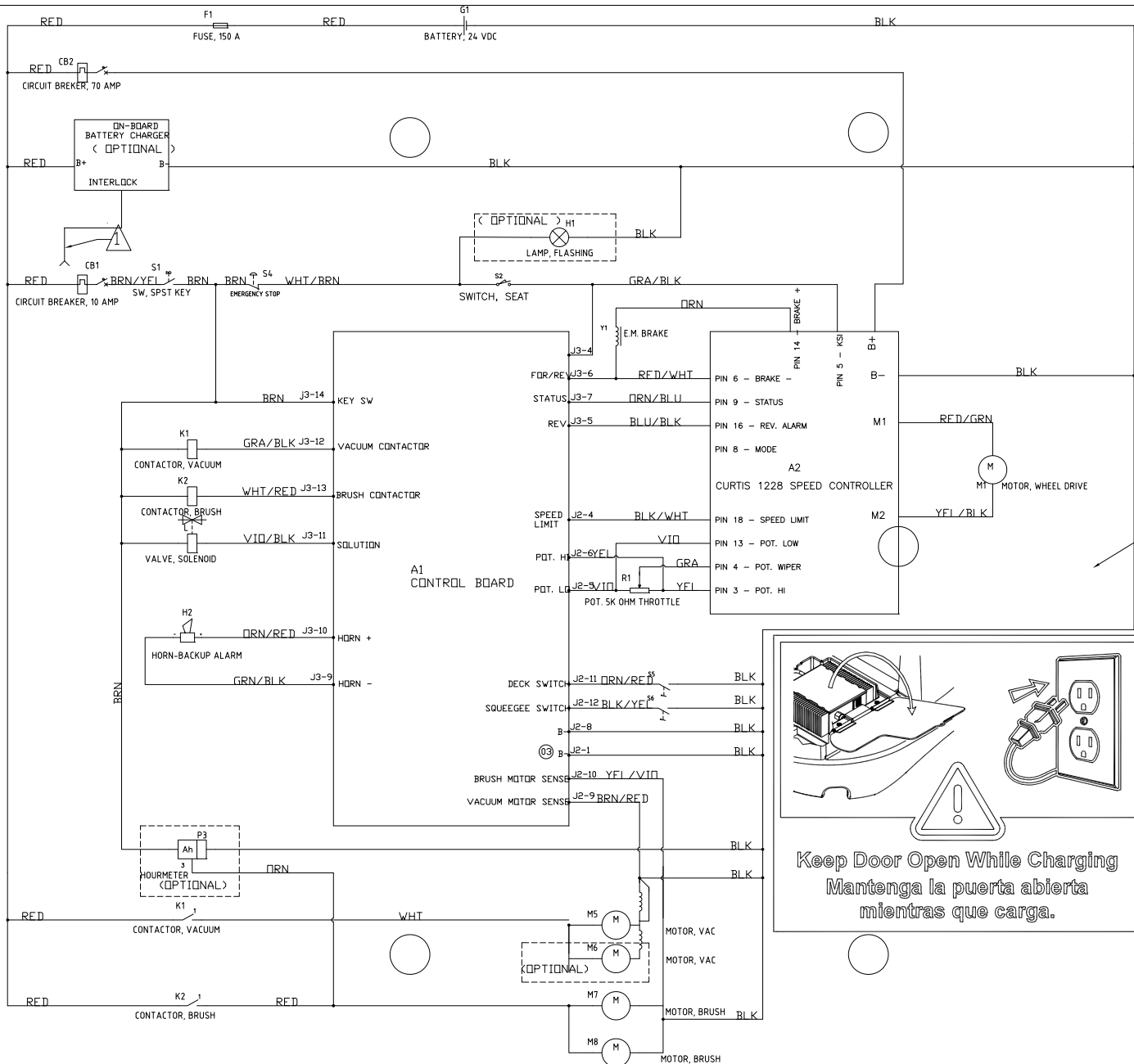

Keep Door Open While Charging
Mantenga la puerta abierta mientras que carga.

NOTES:
 ⚠ DISCONNECT RED WIRE ON CB2 AND REPLACE WITH GREEN WIRE FROM CHARGER WHEN ON BOARD CHARGER IS USED
 REF. DRAWING 56601179 DIAGRAM, ST WIRING

08-11

WIRING DIAGRAM-ST

08-12

Advenger™**41**

Item	Ref. No.	Qty	Description
A1	56601566	1	Control PCB Assy
A2	56601061	1	Speed Control
BAT	N/A		Battery
F1	56412089	1	Fuse, 150 Amp
CB1	56454429	1	Circuit Breaker, 70 Amp
CB2	56507644	1	Circuit Breaker, 10 Amp
H1	56307166	1	Beacon, Warning (optional)
H2	56412177	1	Horn/Backup Alarm
K1	56601183	1	Contactactor 24v, 100 Amp
K2	56412179	1	Contactactor 24v
L1	56601064	1	Solenoid Valve Assy
M1	56601050	1	Motor / Drive Wheel
M5	56601132	1	Motor, Vac 24vdc
M6	56601132	1	Motor, Vac 24vdc (optional)
M7	56601134	2	Motor Gearbox Assy
M8	56601134	2	Motor Gearbox Assy
R1	N/A	1	Part of 56601052
S1	56303553	1	Key Switch
*	56303526	A/R	Replacement Key Set
S2	7-82-00050	1	Switch, Seat
S4	56407130	1	Disconnect, Emergency
Y1	56601507	1	Brake, Electromagnetic
	56315124	1	Charger, On-Board 24v TSBUS2008-984

OPTIONAL KITS AND ACCESSORIES

08-11

42

Advenger™

09-3

Item	Ref. No.	Qty	Description	Item	Ref. No.	Qty	Description
			Kits				28" Disk Scrub Brushes
*	56397453	1	Kit-Battery Fill Indicator	*#	56505800	2	Short Trim Pad Holder
*	7-03-04249	1	Kit-Seat Armrests	*#	56505195	2	Pad Retainer for 56505750
*	56601085	1	Kit-Warning Beacon	*#	56505801	2	MagnaGrit
*	56601087	1	Kit-Vacuum Wand With Caddy	*#	56505802	2	DynaGrit
*	56422162	1	Kit-Seat Belt	*#	56505803	2	AgLite
*	56601098	1	Kit-Dual Vac Motor	*#	56505804	2	Prolene
*	56601527	1	Battery Watering Kit	*#	56505805	2	Prolite
*	56302198	1	Kit-Hour Meter	*#	56505806	2	Union Mix
*	56315732	1	Quiq Programmer Kit	*#	56505807	2	MidGrit
*	56601086	1	Kit-Debris Tray	*#	56505808	2	MidLite Grit
*	56601088	1	Kit-Vacuum Sound Reduction				34" Disk Scrub Brushes
*	56601089	1	Kit-Seat Upgrade	**#	56505780	2	Short Trim Pad Holder
*	56601093	1	Kit-Solution Drain Hose	**#	56505195	2	Pad Retainer for 56505750
*	56601546	A/R	Kit-28" Disk Deck	**#	56505781	2	MagnaGrit
*	56601547	A/R	Kit-34" Disk Deck	**#	56505782	2	DynaGrit
*	56601548	A/R	Kit-28" Cylindrical Deck	**#	56505783	2	AgLite
				**#	56505784	2	Prolene
				**#	56505785	2	Prolite
				**#	56505786	2	Union Mix
				**#	56505787	2	MidGrit
				**#	56505788	2	MidLite Grit
							28" Cylindrical Scrub Brushes
				**#	56412191	2	Soft Nylon
				**#	56412192	2	Hard Nylon
				**#	56412046	2	Prolene
				**#	56412193	2	180 Grit
				**#	56412194	2	80 Grit
				**#	56412195	2	46 Grit
							* = Optional, Not Included
							# = Revised or new since last update
							NOTE 1: All squeegee blade kits include both front and rear squeegee blades.
							NOTE 2: All disk deck blade kits include all side skirt blades.
							NOTE 3: All cylindrical deck blade kits include all blades necessary.
			28" Squeegee Blade Kits				
*#	56601531	1	Blade Kit-Squeegee-Standard NOTE 1				
*#	56601529	1	Blade Kit-Squeegee-Polyurethane NOTE 1				
*#	56601083	1	Blade Kit-Squeegee-Red Gum NOTE 1				
			34" Squeegee Blade Kits				
#	56601532	1	Blade Kit-Squeegee-Standard NOTE 1	**#	56412191	2	Soft Nylon
*#	56601530	1	Blade Kit-Squeegee-Polyurethane NOTE 1	**#	56412192	2	Hard Nylon
*#	56601094	1	Blade Kit-Squeegee-Red Gum NOTE 1	**#	56412046	2	Prolene
			Disk Deck Blade Kits	**#	56412193	2	180 Grit
*#	56601092	1	Blade Kit-Gum NOTE 2	**#	56412194	2	80 Grit
*#	56601091	1	Blade Kit-PU NOTE 2	**#	56412195	2	46 Grit
*#	56601678	1	Blade Kit-Red Gum NOTE 2				
			Cylindrical Deck Blade Kits				
*	56316194	1	Blade Kit-Gum NOTE 3				
*	56601538	1	Blade Kit-PU NOTE 3				
*#	56601681	1	Blade Kit-Red Gum NOTE 3				
			Optional Batteries				
*	56391391	4	Battery, 6V, 305A/H TSBUS2008-984				
*	56206079	4	Battery, 6V, 235A/H TSBUS2008-984				
*	56315959	4	Battery, 6V, 315A/H AGM TSBUS2008-984				
*	56388582	4	Battery, 6V, 395A/H TSBUS2008-984				
			Optional Battery Chargers				
*	56372947	A/R	Battery Charger, 24VDC, Auto, 20Amp, 120VAC/60HZ				
*	56388109	A/R	Battery Charger, 24VDC, Auto, 25Amp, 120VAC/60HZ				
*	56412272	A/R	Battery Charger, 24VDC, Auto, 36Amp, 120VAC/60HZ				
*	56372203	A/R	Battery Charger, 24VDC, 20Amp, 230VAC/50HZ				
*	56412271	A/R	Battery Charger, 24VDC, 40Amp, 230VAC/50HZ				
			Accessories				
*	56409441	A/R	Programmer, 1311 User				
*	56409823	A/R	Programmer Cable				
*	56044418	A/R	Literature Pack				

We provide brushes and pad holders that will give you the best possible performance between machine and floor. Following are descriptions of the materials and their applications.

Union Mix:	Medium grade natural fibers for polishing finished floors with standard-speed equipment. Recommended for use in place of white pads.
ProLite:	Bristles are made from light-duty polypropylene for general scrubbing when you do not want to scratch or remove finish from the floor. Recommended for use in place of red pads.
Prolene:	Polypropylene material for medium-duty scrubbing on concrete, terrazzo and vinyl floor tile. Recommended for use in place of green or blue pads.
Magna Grit:	For extreme heavy-duty scrubbing or stripping of floors. This brush has extra large diameter silicon carbide grit impregnated synthetic bristles. Recommended for use in place of black pads.
Dyna Grit:	For aggressive, heavy-duty scrubbing or stripping of floors. Recommended for use in place of brown pads.
MidLite Grit:	For general purpose scrubbing of sealed or unsealed concrete, stone, terrazzo, quarry tile and other resilient hard floor surfaces. Recommended for use in place of green or blue pads.
MidGrit:	For general purpose scrubbing when you need a lighter action for sealed or unsealed concrete, stone, terrazzo, quarry tile and other resilient hard floor surfaces. Recommended for use in place of green or blue pads.
AgLite Grit:	For light scrubbing when used wet; buffing or polishing when used dry on urethane coated, sealed concrete or other resilient hard surface floors. Recommended for use in place of red or white pads.
Short Trim Pad Holder:	Made with a structural foam block and center ring for correct pad centering. It has a "shower feed" design for getting solution to the floor.

28" BRUSHES

56505800 - Short Trim Pad Holder
 56505195 - Pad Retainer for 56505800
 56505801 - Magna Grit
 56505802 - Dyna Grit
 56505803 - AgLite Grit
 56505804 - Prolene
 56505805 - ProLite
 56505806 - Union Mix
 56505807 - MidGrit
 56505808 - MidLite Grit

34" BRUSHES

56505830 - Short Trim Pad Holder
 56505195 - Pad Retainer for 56505830
 56505831 - Magna Grit
 56505832 - Dyna Grit
 56505833 - AgLite Grit
 56505834 - Prolene
 56505835 - ProLite
 56505836 - Union Mix
 56505837 - MidGrit
 56505838 - MidLite Grit

DISC BRUSH APPLICATION GUIDE (SUGGESTION ONLY)

Application	46 Grit	80 Grit	180 Grit	240 Grit	500 Grit	Prolene	ProLite	Union Mix
Stripping:								
Concrete	X	X						
Terrazzo	X	X						
Ceramic/Quarry tile		X						
Vinyl tile		X						
General Scrubbing:								
Concrete	X	X	X	X		X		
Terrazzo			X	X	X	X		
Ceramic/Quarry tile			X	X	X	X		
Marble					X		X	
Vinyl tile			X		X	X		
Raised-rubber tile					X		X	
Polishing:								
Raised Disc Tile								X
Marble								X
Vinyl tile								X

We provide brushes and pad holders that will give you the best possible performance between machine and floor. Following are descriptions of the materials and their applications.

- 46 Grit Brush: Most aggressive grit brush. Used primarily to clean heavy buildup on concrete floors in factories, or for heavy stripping of finish.
- 80 Grit Brush: Medium aggressive grit brush. Good all-around brush for medium to heavy buildup removal. Can also be used for general stripping operations.
- 180 Grit Brush: Least aggressive grit brush. Used for daily cleaning of hard-finished floors.
- Polypropylene Brush: Standard equipment brush. Low cost, yet effective in cleaning many common floor surfaces.
- Stiff Nylon Brush: Cleaning action similar to polypropylene. More durable and wear-resistant than polypropylene.
- Soft Nylon Brush: Least aggressive brush available. Used on soft-finish floors where a more aggressive brush would leave scratch marks, or in applications requiring very light cleaning.

28" BRUSHES

- 56412191 - Soft Nylon
 56412192 - Hard Nylon
 56412046 - Prolene
 56412193 - 180 Grit
 56412194 - 80 Grit
 56412195 - 46 Grit

CYLINDRICAL BRUSH APPLICATION GUIDE (SUGGESTION ONLY)

Application	46 Grit	80 Grit	180 Grit	Polypro- pylene	Stiff Nylon	Soft Nylon
Stripping:						
Concrete	X	X				
Terrazzo	X	X				
Ceramic/Quarry tile		X				
Vinyl tile		X				
General Scrubbing:						
Concrete	X	X	X	X	X	
Terrazzo			X	X	X	X
Ceramic/Quarry tile			X	X	X	X
Marble			X		X	X
Vinyl tile			X	X	X	X
Raised-rubber tile			X			X



**Nilfisk
Advance**

setting standards

Nilfisk-Advance, Inc.
14600 21st Avenue North
Plymouth, MN 55447-3408
www.nilfisk-advance.com
Phone: 800-989-2235
Fax: 800-989-6566
©2009 Nilfisk-Advance, Inc.