

FM800 REV

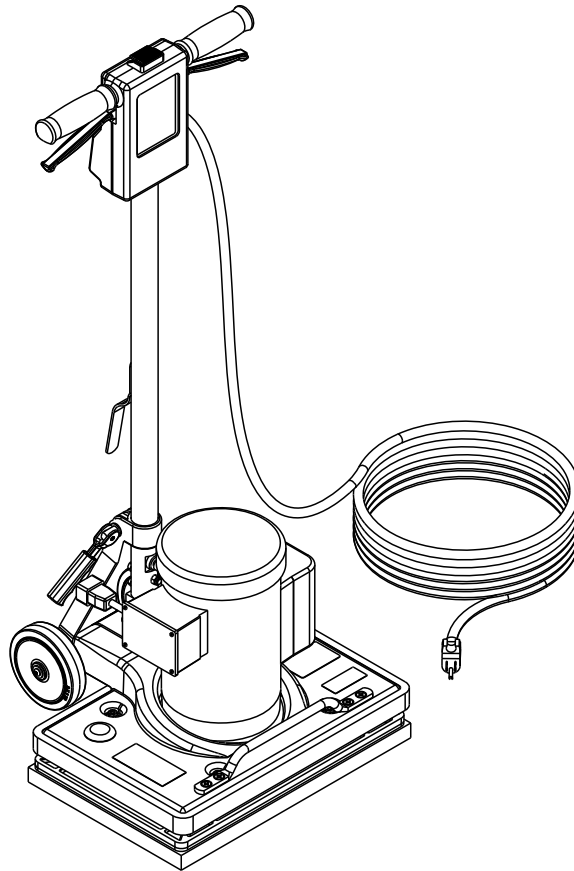

PARTS LIST

MODEL 56382452

TABLE OF CONTENTS

DESCRIPTION	PAGE
General View and Options	1
Handle Assy	2-3
Wiring Diagram	3
Base Assy	4-5

WHEN ORDERING PARTS

- * Use the part numbers from the "Ref. No." columns in this parts list.
- * Specify the model and serial number of the machine.
- * Use the space below to record the model and serial number for future reference.

Model _____ Serial No. _____

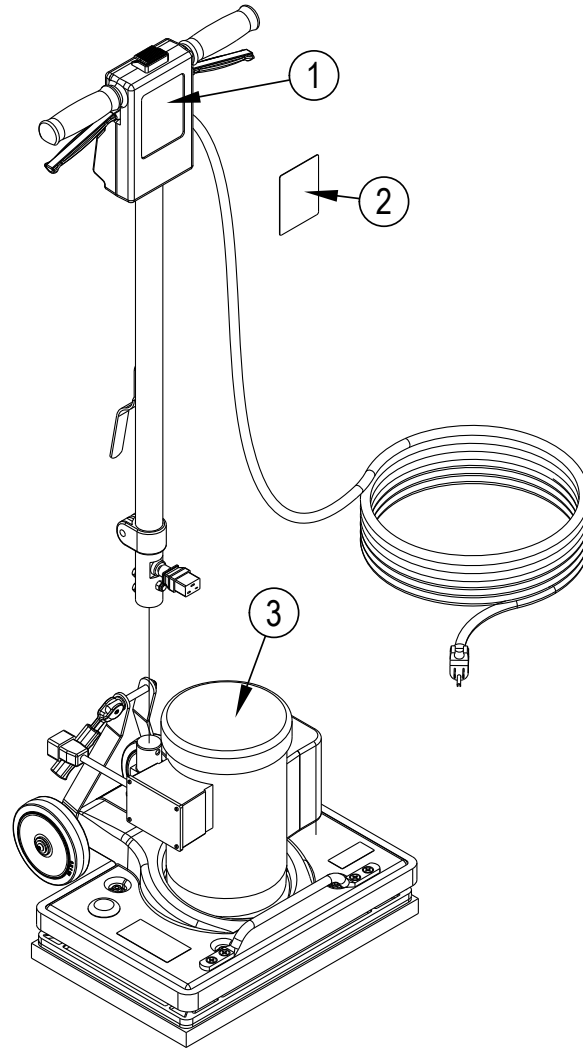

GENERAL VIEW AND OPTIONS

Item	Ref. No.	Qty	Description
1		1	Gen II Handle Assy
2	56382455	1	Decal-FM800 REV
3		1	Gen II Base Assy
OPTIONS			
*	976555	1	Pads 12x18 Black Strip
*	30730A	1	Pad 12 X 18 Maroon 10 ea/case
*	976558	1	Pads Cs 5 12x18 Red Buffer
*	976559	1	Pads Cs 5 12x18 White Polish
*	50026B	1	Tank Asm. 4 Gal. Black

* = Optional, Not Included

HANDLE ASSY

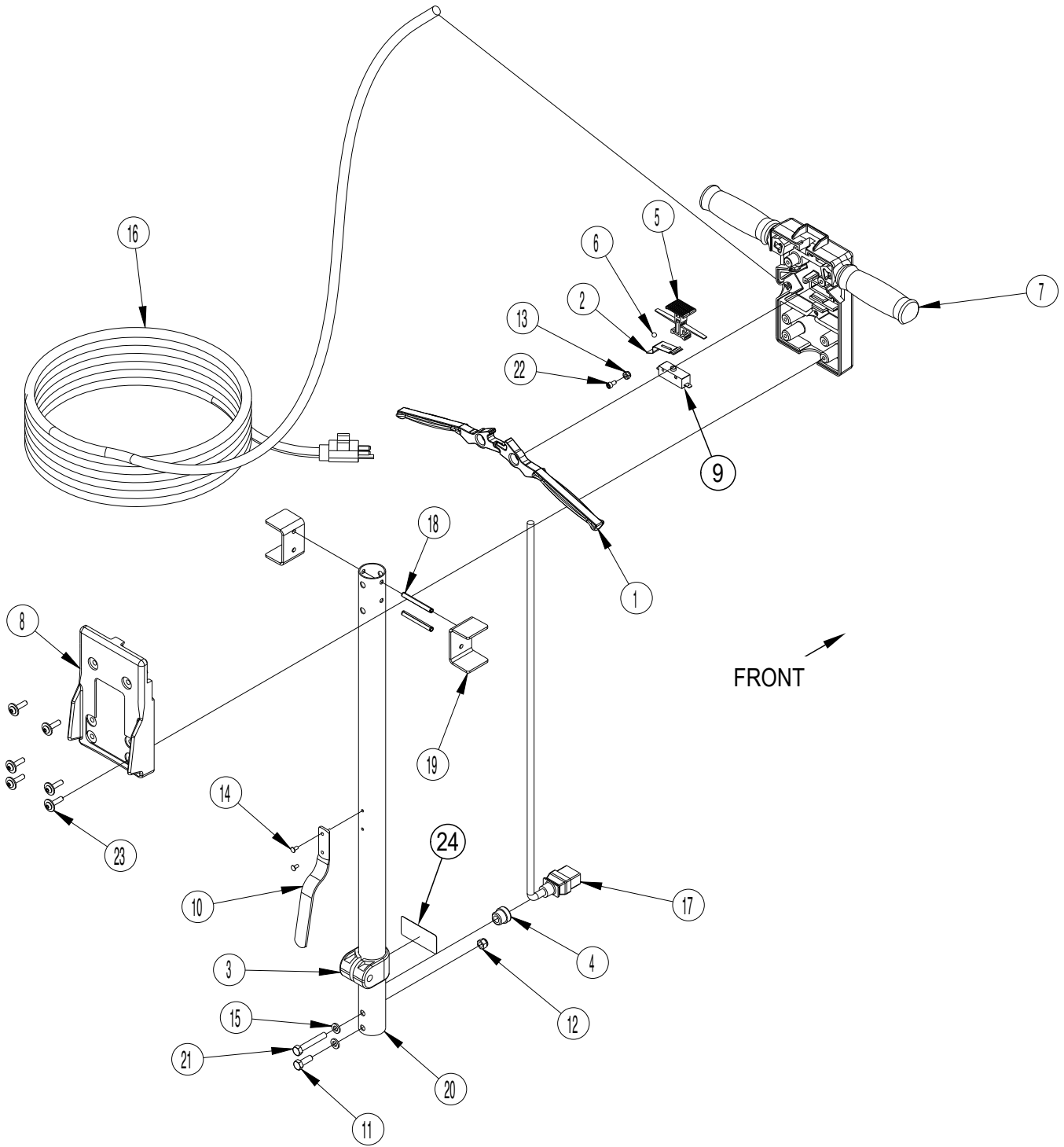

HANDLE ASSY

Item	Ref. No.	Qty	Description
1#	56201027	2	Handle Lever
2#	56263648	1	Spring, Plate
3	442001	1	Clamp-Handle Tube
4	627561	1	Strain-Relief
5	56201031	1	Button, Lock
6	56201592	1	Ball, 1/4 Ss
7	56201656	1	Handle, Front
8	56201657	1	Handle, Back
9	40949A	1	Switch Spstno 25a 125vac Ulcsa
10	64325A	1	Hook-Cord
11	85812A	1	Screw 5/16-18 X 7/8 Hex Hd Gr5
12	920110	1	Nut, 5/16-18 Hex Lock
13	920722	1	Nut 10-32 Esna
14	930005	2	Rivet_5/32 X .32
15	980652	2	Washer, 5/16 Lock
16	40760A	1	Cord Power
17	56382460	1	Cord-No Relief Interconnect
18	53834A	2	Pin, Coiled
19	61726A	2	Support, Handle Mnt
20	61825A	1	Tube-Handle
21	85817A	1	Screw 5/16-18 X 2.00 Hex HD GR5
22	80290A	1	SCREW 10-32 X .38 HRCS
23	80292A	6	Screw .25-20 X 1.00 Bhhr Sems
24	56382459	1	Decal-Handle Release

= Revised or new since last update

WIRING DIAGRAM

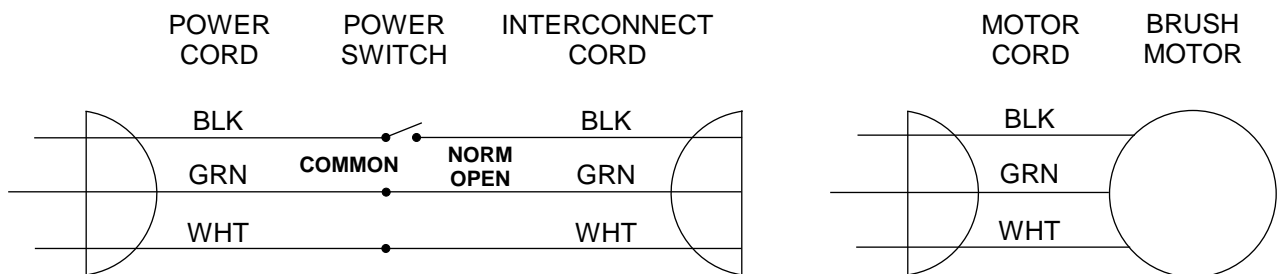

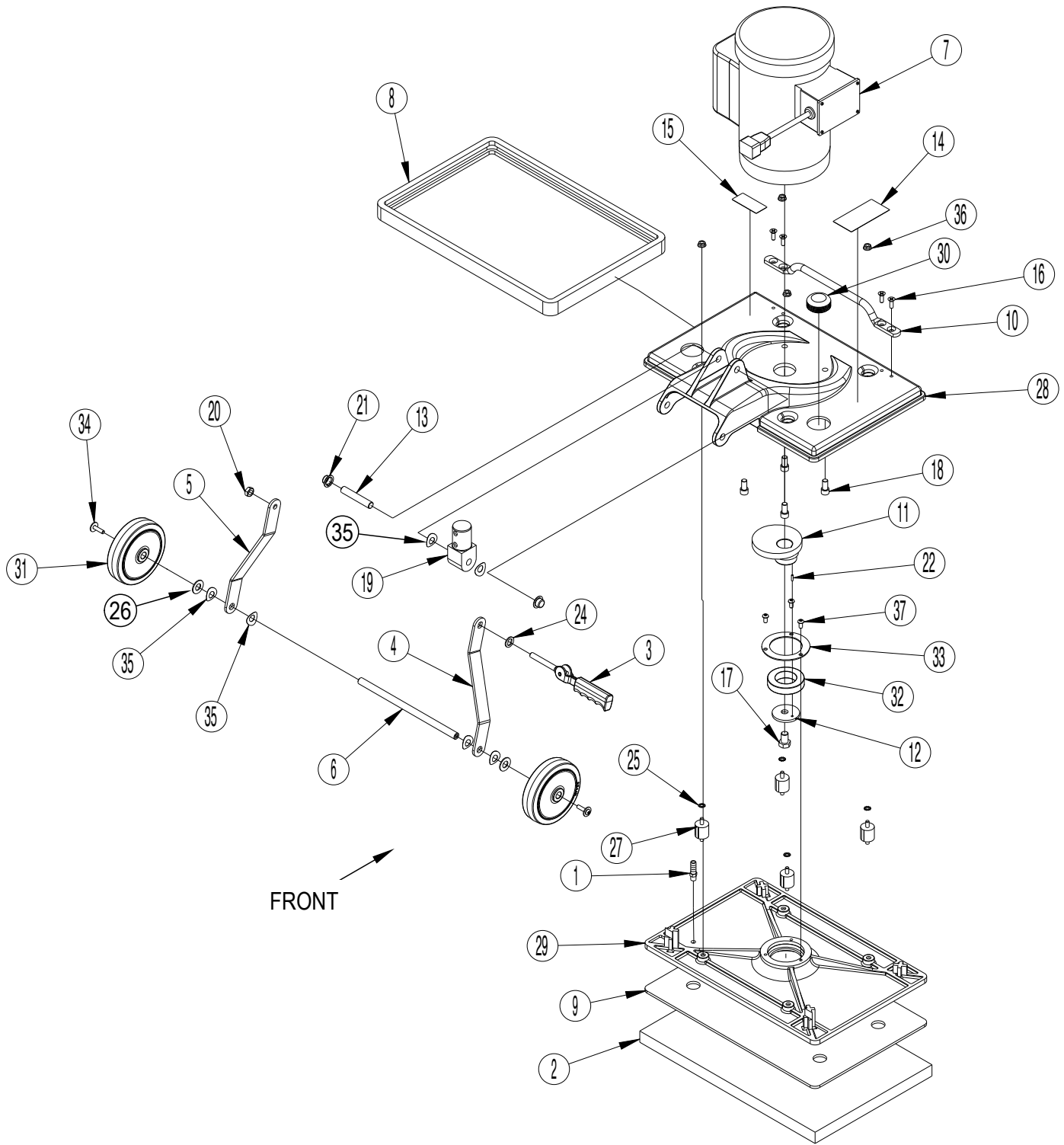

BASE ASSY

Item	Ref. No.	Qty	Description
1	690209	1	Hosebarb 3/8h X 1/8 Npt
2	56382759	1	Pads Red 12x18
3	56109699	1	Cam Assy With Gripcam Assy With Grip
4	56381766	1	Link-Arm Right
5	56381767	1	Link-Arm Left
6	56381768	1	Shaft-Axle
7	56382454	1	Motor-1hp
[]	56382457	1	Capacitor-Start (for 56382454)
[]	56382458	1	Switch-Stationary (for 56382454)
[]	56382461	1	Capacitor-Run (for 56382454)
8	31224B	1	Bumper Frame Black
9	39730A	1	Grip Face
10	54930A	1	Handle-Lift
11	62814A	1	Eccentric Obs-18
12	66982A	1	Retainer, Eccentric
13	67474A	1	Shaft-Handle Pivot
14	77195A	1	Label-UI Fire & Sand.
15	77234A	1	Plate-Warning
16	84233A	4	Screw 1/4-20 X 3/4 Fh Sy Ph
17	85718A	1	Scr 1/2-13 X 3/4 Hc St Grd 2
18	86112A	4	Screw-3/8-16 X 3/4-socket Head
19	509240	1	Tongue, Handle Tube
20	920248	1	Nut, 3/8-16. Esna, Jam
21	920346	2	Palnut #Pw500015 Type W
22	925589	1	Pin, Roll
24	980349	1	Washer Wear Cam
25	980614	4	Washer, 1/4" Starlock, External
26	980648	2	Washer 17/32 X 1 1/16 Plain
27	56380193	4	Isolator-40 Duro 1/4-20
28	25908A	1	Mainframe Obs-18dc
29	29931A	1	Base-Orbital
30	39734A	1	Plug Hole 1 3/4
31	39857A	2	Wheel 5 X 1.50 X .500
32	50736A	1	Bearing
33	66981A	1	Retainer, Bearing
34	80292A	2	Screw .25-20 X 1.00 Bhhr Sems
35	80295A	6	Washer Bowed
36	81220A	4	Nut, Serrated Flange
37	87700A	3	Screw 1/4-20 X 1/2 B.H.

[] = Not Shown



Nilfisk-Advance Equipamentos de Limpeza Ltda.
Av. Dep. Emílio Carlos, 2.499 - Bairro do Limão - 02721-200
São Paulo - SP - Brasil
www.nilfisk-advance.ind.br
www.plataforma.ind.br
Tel.: (11) 3959-0300
Fax: (11) 3959-0306
©2012 Nilfisk-Advance, Inc.



14600 21st Avenue North
Plymouth, MN 55447-3408
www.advance-us.com
Phone: 800-989-2235
Fax: 800-989-6566
©2012 Nilfisk-Advance, Inc.

A Nilfisk-Advance Brand